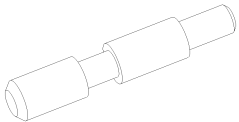
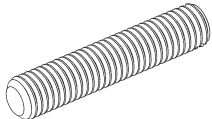

orangebox

New Product Development

Border 03 Assembly Instructions (no power unit)
V1 October 09

2 x  M8 threaded foot-rail mounting pin

4 x  M8 x 60 threaded stud

4 x  M8 large diameter washer

4 x  M8 nut

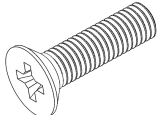
7 x  M6 x 35 Countersunk head machine screw

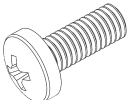
6 x  M6 x 16 Pan head machine screw

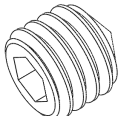
2 x  M6 x 6 Hex socket set screw

1 x

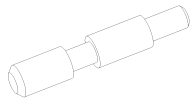

M8 threaded foot-rail mounting pin

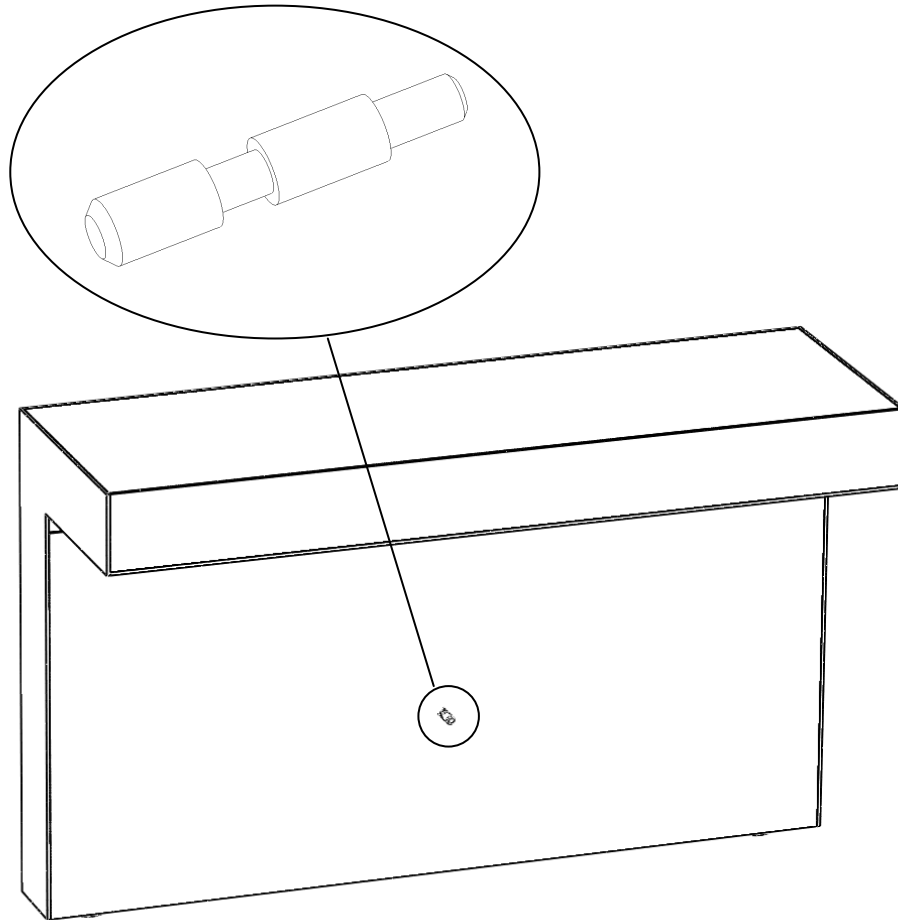

orangebox

- 1) Screw one of the foot-rail mounting pins in to the hole in the centre of the upholstered seat unit as shown.

Tighten by hand until all the way in

1 x

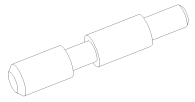

M8 threaded foot-rail mounting pin

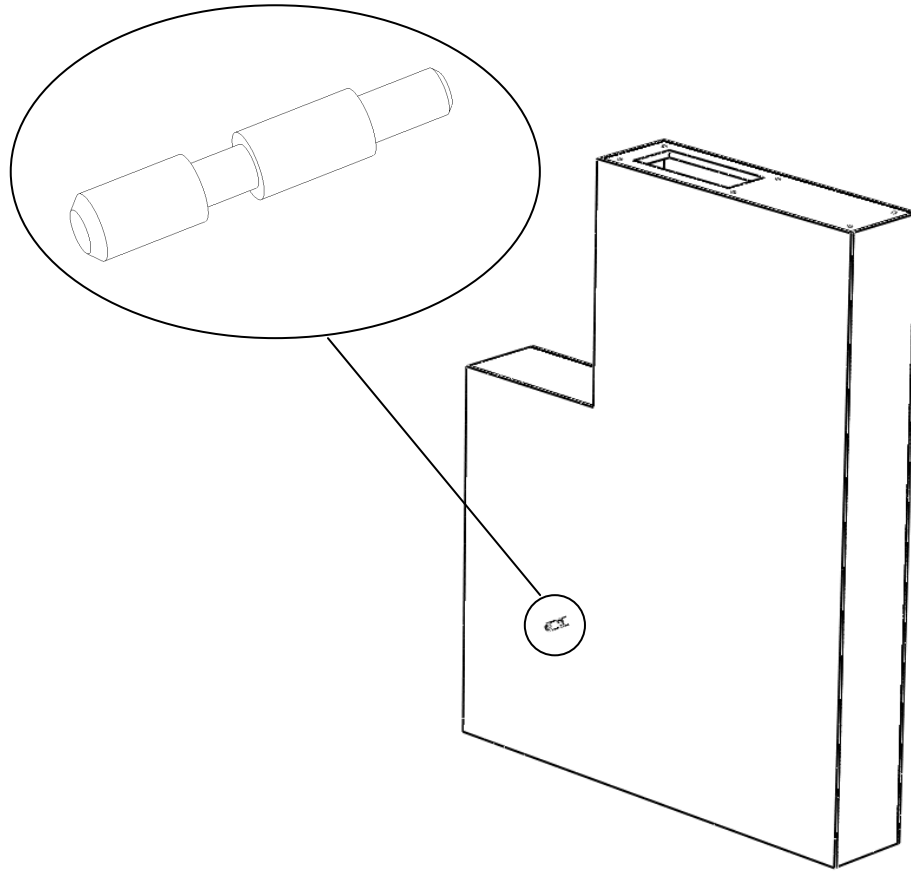

orangebox

- 2) Screw one of the foot-rail mounting pins in to the hole in the centre of the upholstered table unit as shown.

Tighten by hand until all the way in

4 x

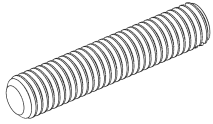

M8 x 60 threaded stud

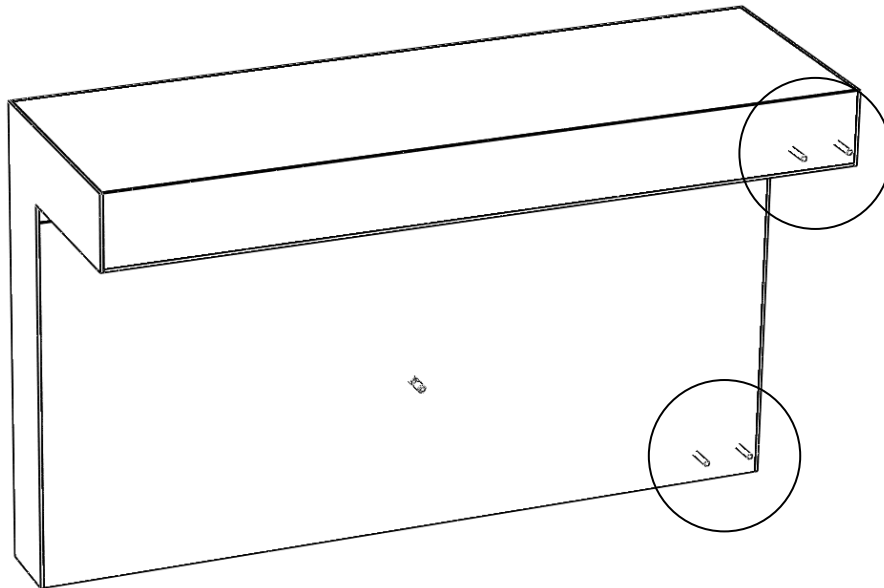

orangebox

- 3) Screw 4 x M8 stud into the threaded inserts in the upholstered seat unit – 2 at the top and 2 at the bottom (this may have been done for you when you receive the unit)

The stud should be inserted to a depth of approx 15mm i.e. approx. 45mm of stud is sticking out of the unit.

orangebox

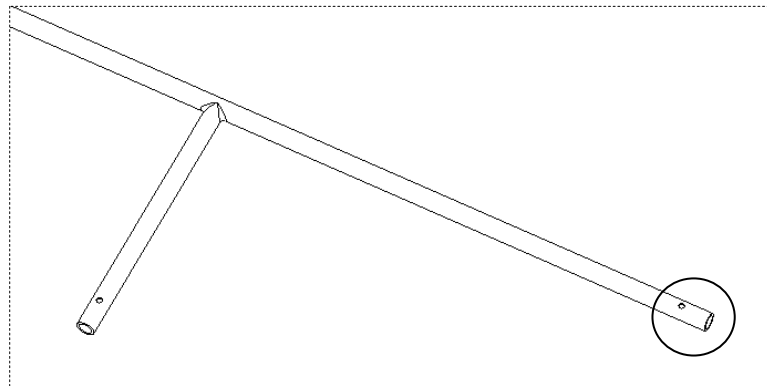
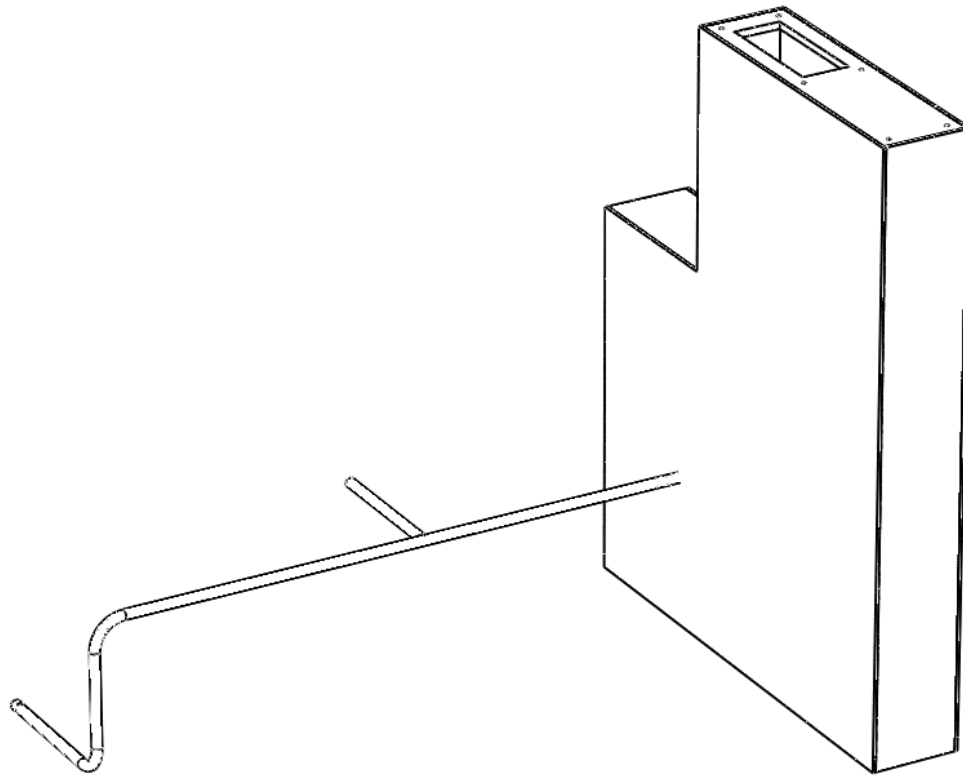

- 4) Slide the foot-rail over the foot-rail mounting pin inserted into the upholstered table unit as shown (in the orientation shown in the image)

Do not tighten the grub screw on the underside of the foot-rail at this point

orangebox

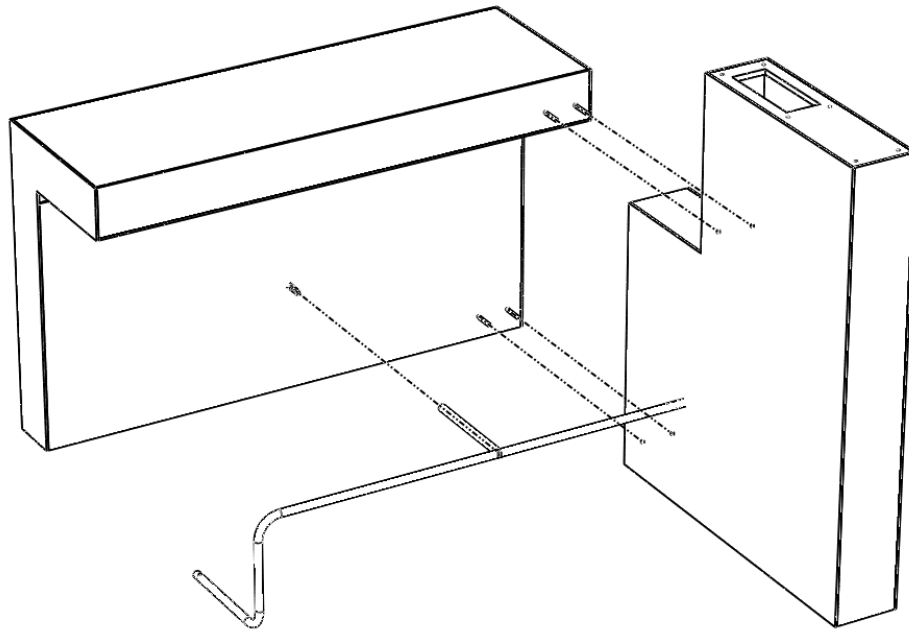

- 5) Locate the table unit and foot-rail on the upholstered seat unit

The foot-rail should now locate over both foot-rail mounting pins

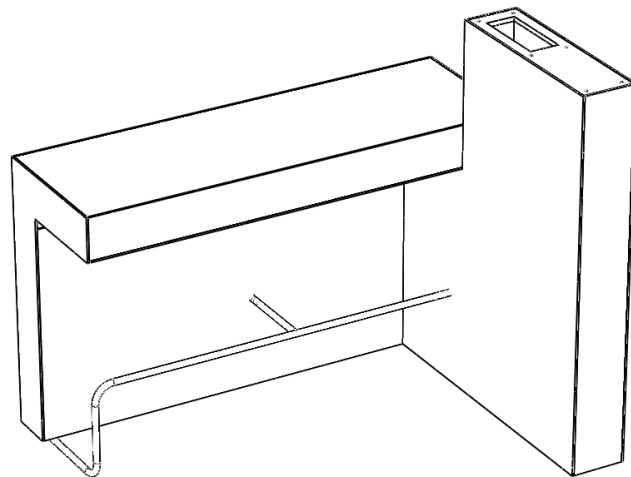

The far end of the foot-rail (non-table unit end) locates on the underside of the seat unit

2 x  M8 large diameter washer

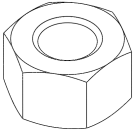
2 x  M8 nut

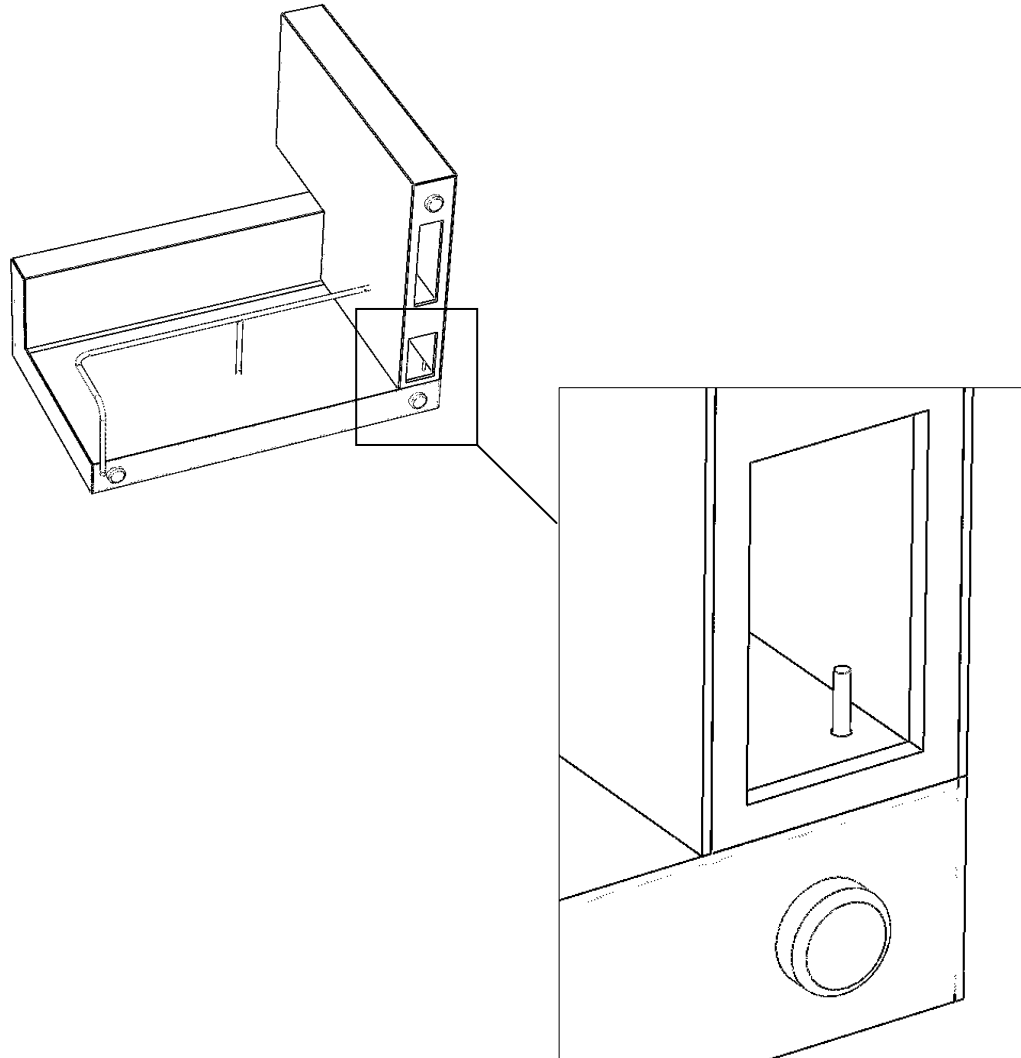

orangebox

- 6) Using 2 people - carefully lay the assembled units onto the floor – so the back of the seat unit sits against the floor

(ensure the floor is clean or that the unit is placed onto protective material)

Working inside the table unit at the bottom of the frame - drop an M8 washer over both of the M8 studs

Then spin an M8 nut on to each thread and tighten loosely at this point

2 x  M8 large diameter washer

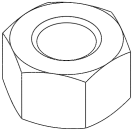
2 x  M8 nut

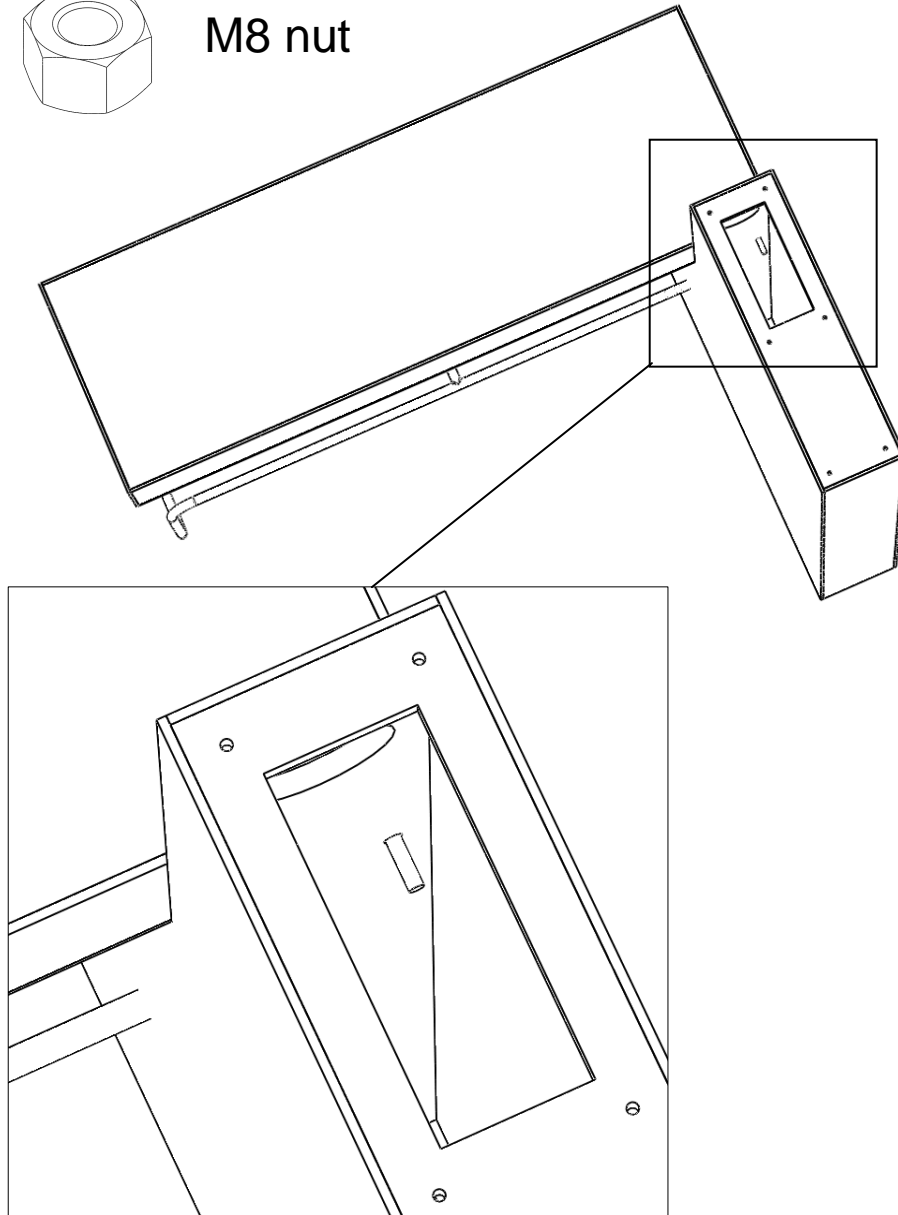

orangebox

7) Working inside the table unit at the top of the frame - repeat the placement of washer and nut onto the two studs

Then tighten all 4 nuts, top and bottom, using an appropriate socket (13mm) until the table unit is firmly held against the seat unit with no movement between the two

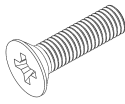
1 x  M6 x 35 Countersunk head machine screw

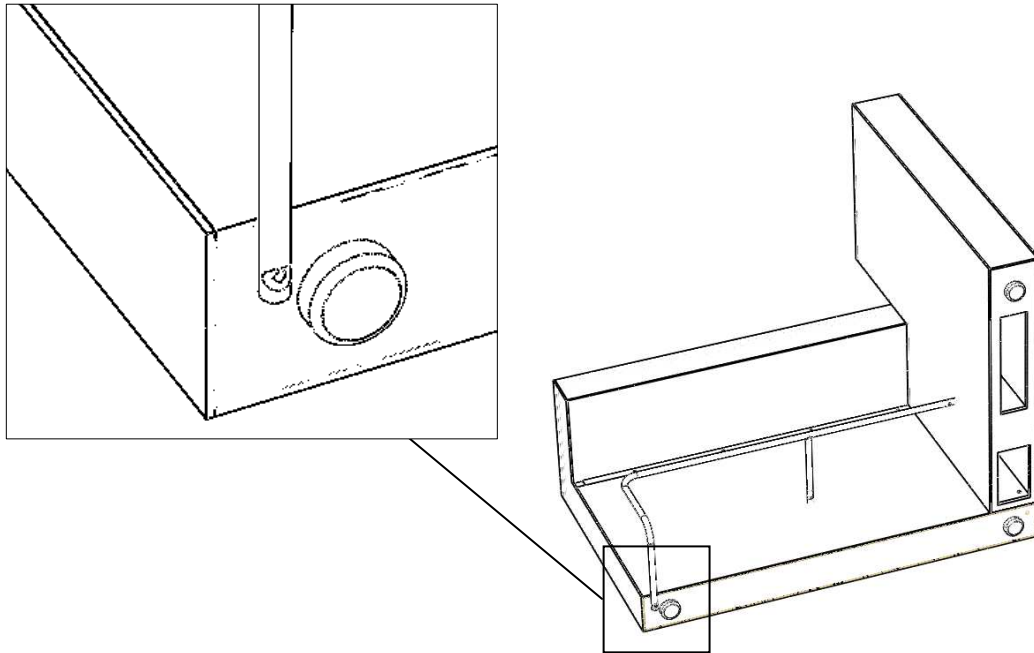

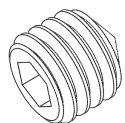
2 x  M6 x 6 Hex socket set screw

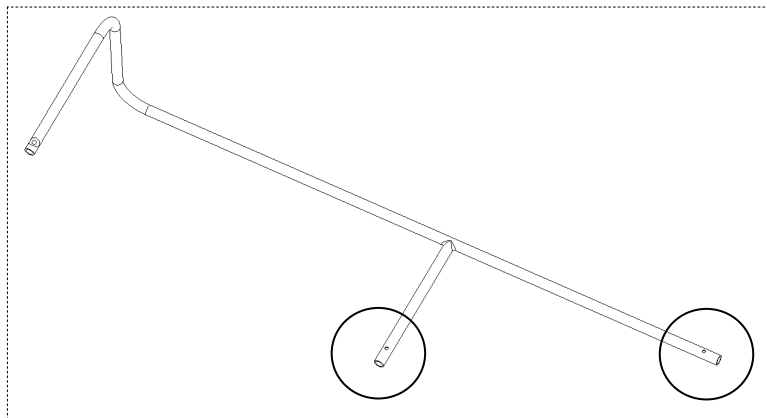

orangebox

- 8) Insert and tighten 1 x M6 screw with countersunk head through the hole at the end of the foot-rail (on the underside) as shown in the top image

Tighten the 2 x M6 set screws on the underside of the foot-rail in the positions shown in the bottom image

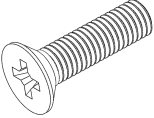
6 x  M6 x 35 Countersunk head machine screw

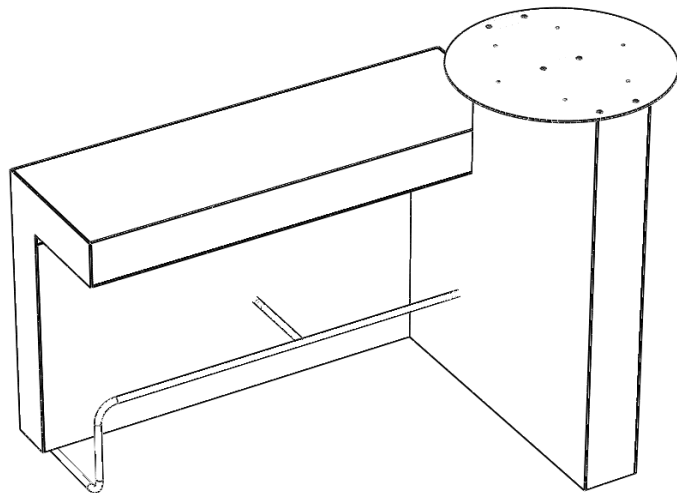
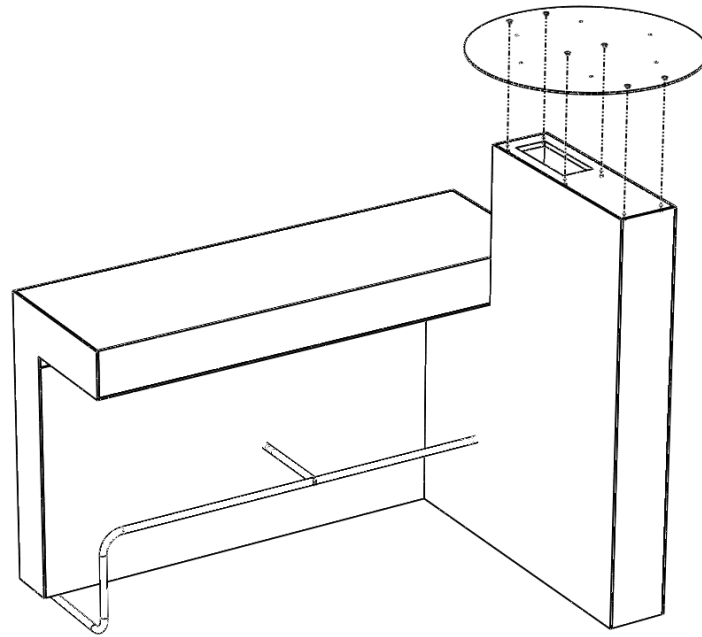

orangebox

9) Using 2 people – carefully place the unit back onto its feet

Then secure the table mounting plate onto the top of the table unit frame using 6 x M6 countersunk fasteners provided

The plate should be oriented such that the countersunk holes are facing upwards when placed onto the table frame

6 x

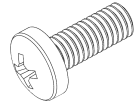

M6 x 16 Pan head machine screw

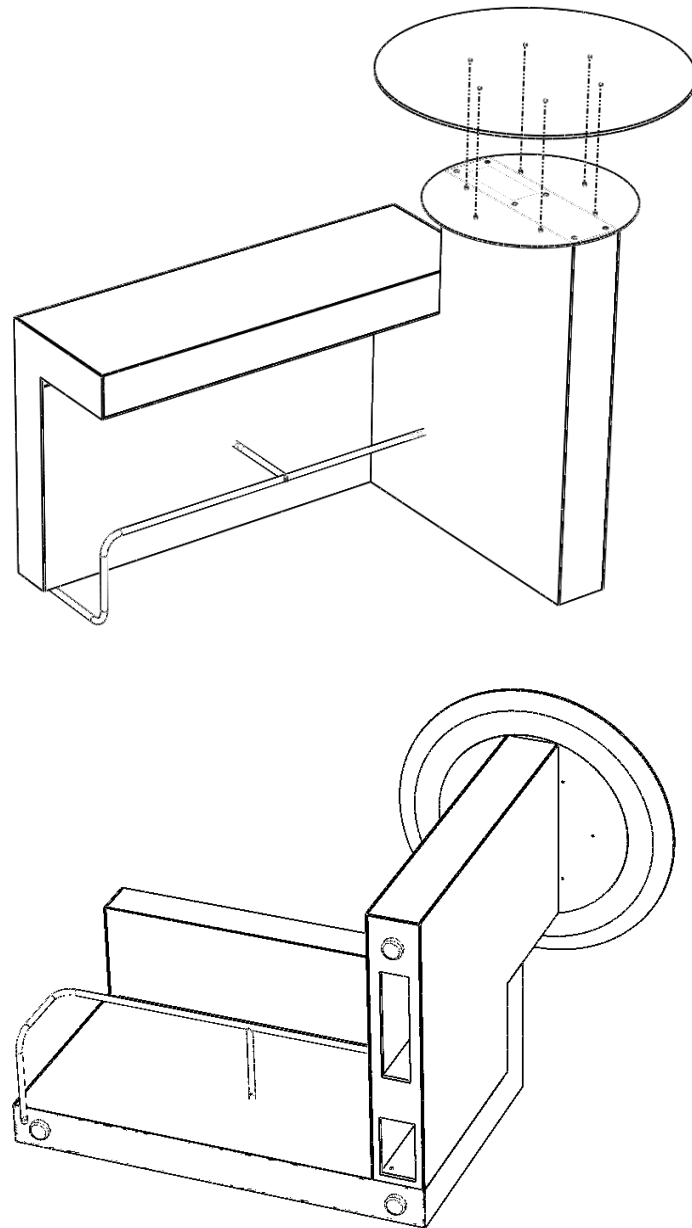

orangebox

10) Locate the table top onto the table mounting plate

Once in place, rotate the table top so that the 6 x fastener holes in the top align with those on the mounting plate (if the top has a wood finish then ensure that the grain of the finish is running the right way)

From the underside of the top, locate and tighten 6 x M6 fasteners

orangebox

11) Ensure correct assembly :

Level to floor (adj. as reqd)

Seat and table units securely fastened to one another

Table top securely fastened to table unit

Foot-rail securely fastened to seat and table frame

Upholstery is clean and lint free

