



Campers & dens.

Intuitively define *your* workspace

Americas Technical Document

Unique, personalizable,
and flexible private spaces.

Contents

Section 1	Introduction
Section 2	Product Range & Accessories
Section 3	User Features
Section 4	Acoustics
Section 5	Integrated Services: Fire Safety
Section 6	Integrated Services: Ventilation
Section 7	Integrated Services: Lighting
Section 8	Integrated Services: Power/Electrical
Section 9	Seismic Kit
Section 10	ADA Compliance /Inclusivity
Section 11	Standards/Compliance
Section 12	Warranty

Section 1

Introduction



Campers & Dens is a comprehensive system of enclosed campers, semi enclosed cabins and awnings which can be used individually or in combination to provide a wide variety of workspace solutions to facilitate collaborative team meetings and individual focused work.

Introduction

Campers & Dens has been designed to remove the complexity that comes with commissioning fixed solutions. In comparison to built-in, bespoke or partitioned office solutions, Campers & Dens is much faster, cleaner and simpler. They can be assembled, dis-assembled and readily re-located to be used again.

Campers come with integrated lighting, air circulation fan and power. When assembled they only need to be

connected to a main power source using a standard 15A plug. The lighting system, air fan and opening roof system automatically activate when a person enters the camper, and automatically turn off after the camper is vacated.

Accessories like cabins and awnings help create layers of privacy to meet employee's individual needs and organizational goals.



Accessories and Finishes

Campers & Dens can be used with a variety of seating, and tables as well as whiteboards and a range of bespoke brackets to take different sized monitors. Additionally there is the opportunity to create unique 'hacked' finishes to the campers.

Flexible Private Space

As they are not fixed to the floor and are not part of the building structure, Campers & Dens can be positioned anywhere within a building as long as there is sufficient ceiling height and an available power source nearby.

Design Features



Patented Opening Roof System

Campers & Dens offers a unique opening/closing roof. The opening roof provides an effective solution for sprinklered buildings and has the added benefit of refreshing the air in the camper between users. The roof is also controlled automatically through the passive infrared sensor.



Acoustic Control

A combination of sound absorption, insulation and seals create the perfect balance for a flexible acoustic meeting and workspace. Effective sound privacy is achieved while maintaining acoustic comfort for conversation inside the camper.



Integrated Services: “Plug-In and Go”

Campers come with integrated lighting, air circulation, fan and power sockets for camper users. When assembled they only need to be connected to a mains power source. The lighting system, air fan and opening roof system automatically activate when a person enters the camper, and automatically turn off after the camper is vacated.



User Control

A control panel provides manual control for the lighting level, fan speed, and roof louver position. The opening roof has a manual control to fully open, partially open, or fully close the roof.



Accessories

Campers & Dens can be furnished with a variety of accessories - seating, tables, whiteboards and brackets to support monitors and tables. Additionally there is the opportunity to select unique finishes to the campers.

Section 2

Product Range & Accessories

Product Overview

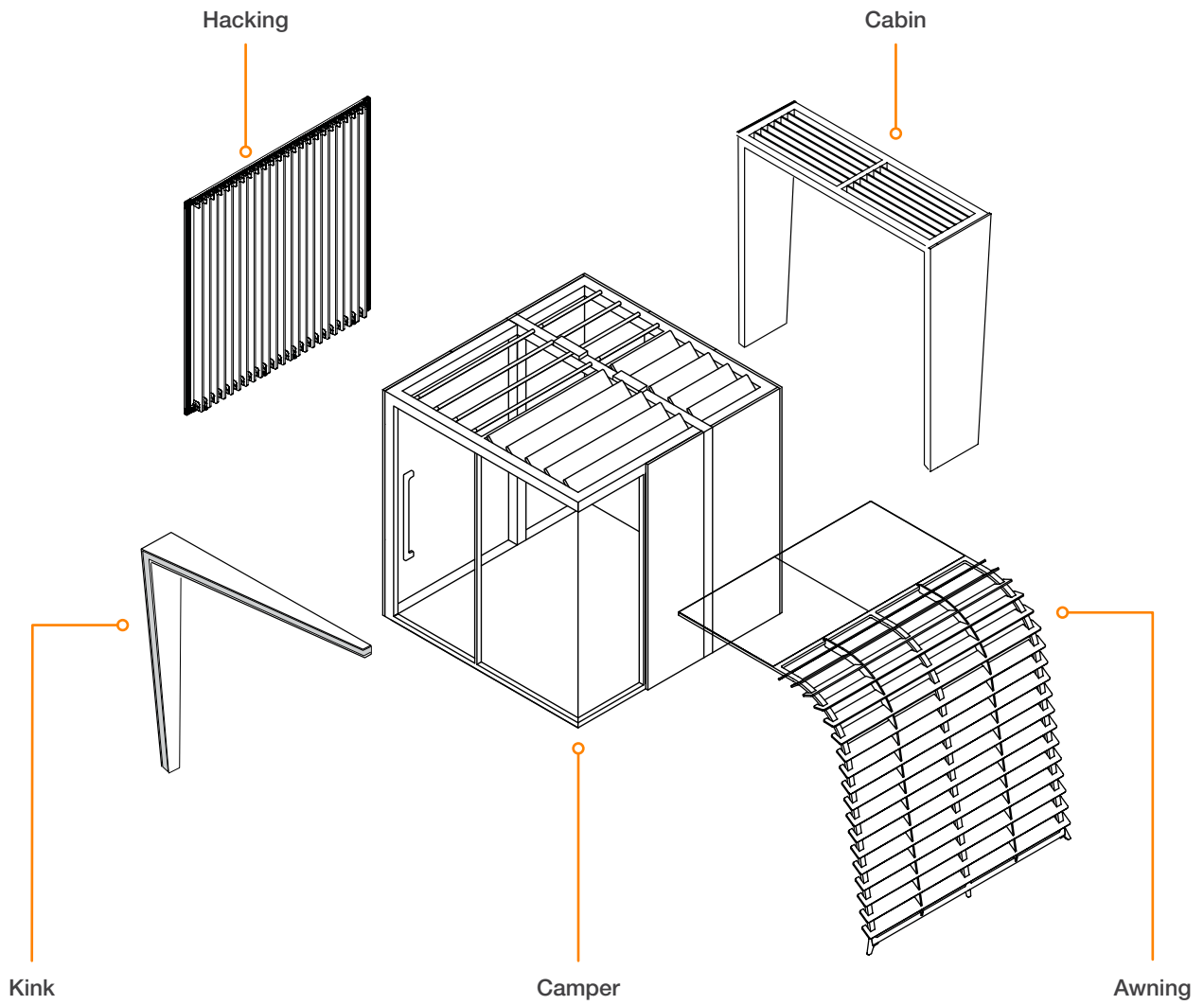

Camper Product Range

CD02 Campers

OB1CD02BLS / OB1CD02BRS

Glass front and rear

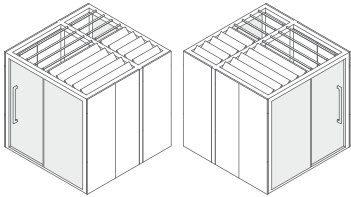

Dimensions:
92"H x 88"W x 92"D

OB1CD02CLS / OB1CD02CRS

Glass front corner

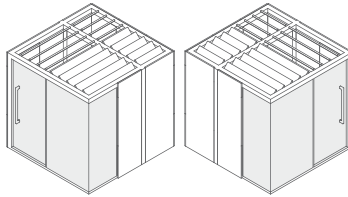

Dimensions:
92"H x 88"W x 92"D

OB1CD02DLS / OB1CD02DRS

Glass front

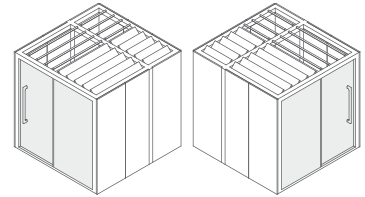

Dimensions:
92"H x 88"W x 92"D

■ Glass

For each pod size there are configurations depending on:

- Wall Panel layout (3 options - B, C or D).
- Left or right hand door options (Handedness is indicated by door position when facing the unit).
- All three configurations (B, C, and D), and handedness are the same for CD02 and CD05.

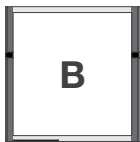

Panel configuration B:
Glass front and rear
(Left hand, OB1CD02BLS shown)

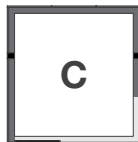

Panel configuration C:
Corner glass front
(Left hand, OB1CD02CLS shown)



Panel configuration D:
Glass front
(Left hand, OB1CD02DLS shown)

Camper Product Range

CD05 Campers

OB1CD05BLS / OB1CD05BRS

Glass front and rear

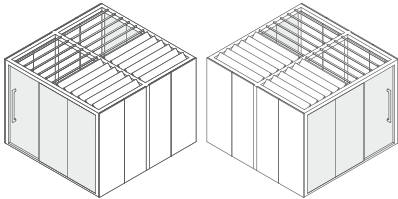

Dimensions:
92"H x 115"W x 119"D

OB1CD05CLS / OB1CD05CRS

Glass front corner

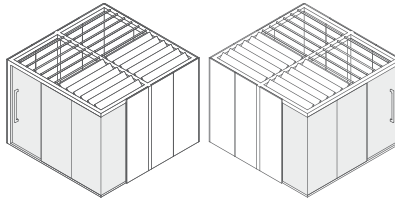

Dimensions:
92"H x 115"W x 119"D

OB1CD05DLS / OB1CD05DRS

Glass front

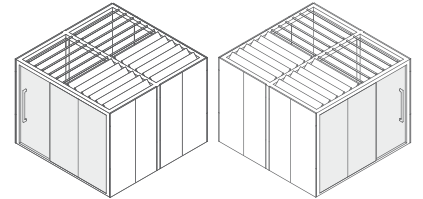

Dimensions:
92"H x 115"W x 119"D

■ Glass

For each pod size there are configurations depending on:

- Wall Panel layout (3 options - B, C or D).
- Left or right hand door options (Handedness is indicated by door position when facing the unit).
- All three configurations (B, C, and D), and handedness are the same for CD02 and CD05.

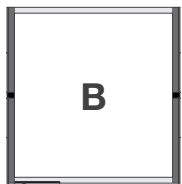

Panel configuration B:
Glass front and rear
(Left hand, OB1CD05BLS shown)

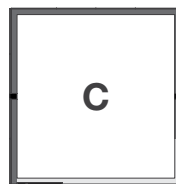

Panel configuration C:
Corner glass front
(Left hand, OB1CD05CLS shown)

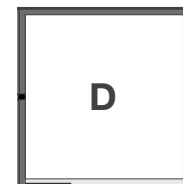

Panel configuration D:
Glass front
(Left hand, OB1CD05DLS shown)

Product Overview

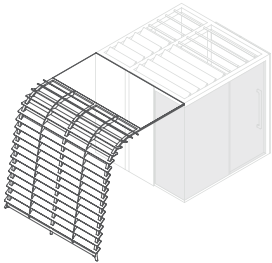

Awning

There is an 'Awning' that can link to the campers to create a screened area.

Dimensions: 89" x 92" (CD02)
115" x 92" (CD05)

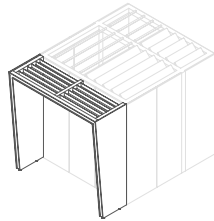

Cabin

There is a 'Cabin' that can be added to the back of the campers.

Dimensions: 28 3/8" x 88" (CD02)
28 3/8" x 115" (CD05)



Kink

There is a 'Kink' accessory that can fit onto the front face of the campers.

Dimensions: 88" x 14" (CD02)
115" x 14" (CD05)

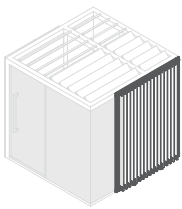

Hacking

Decorative hacking can be added to the campers.

Options: Straight plywood slats or wavy slats.

Available left- or right- handed (depending if door is on the left or on the right)

Materiality: Poplar Plywood

OB1HACK08

Up to Glass Corner

Dimensions: 90"H x 61"W x 11"D

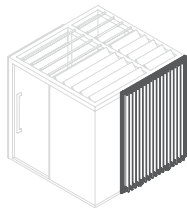

OB1HACK09

Full Camper Depth

Dimensions: 90"H x 92"W x 11"D

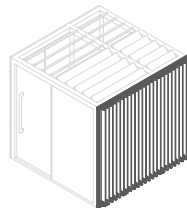

OB1HACK10

Around Corner

Dimensions: 90"H x 96"W x 51"D

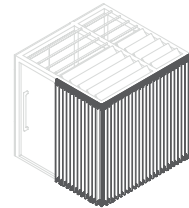

OB1HACK11

Up to Glass Corner

Dimensions: 90"H x 61"W x 11"D

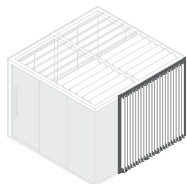

OB1HACK12

Full Camper Depth

Dimensions: 90"H x 92"W x 11"D

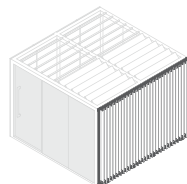

OB1HACK13

Around Corner

Dimensions: 90"H x 96"W x 51"D

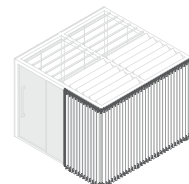

Product Overview

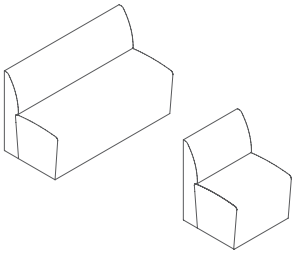

Upholstered Seats

There are both single and double upholstered seats that can be added to cabins.

Dimensions: 32" x 24" x 24 1/2" (Single)
 32" x 50 1/2" x 24 1/2" (Double)

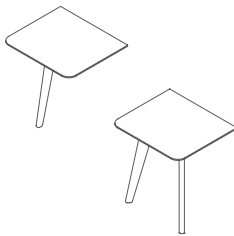

Mounted Table – 24.8" deep

There are mounted tables that can be added to the campers.

Dimensions: 29 3/5" x 28 3/10" x 24 4/5"

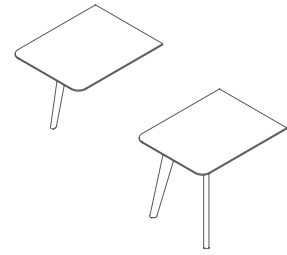

Mounted Table – 35.4" deep

There are mounted tables that can be added to the campers.

Dimensions: 29 3/5" x 28 3/10" x 35 4/5"

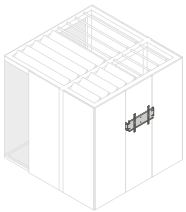

Monitor Mounting Brackets

There are monitor mounting brackets can be added to the campers. Panel Mounted, Hoop Mounted or Seam Mounted options available.

Maximum monitor weight: 100lbs

Panel Mounted
 OB1CDFHMB

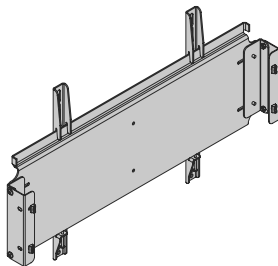

Hoop Mounted
 OB1CFHMMBS

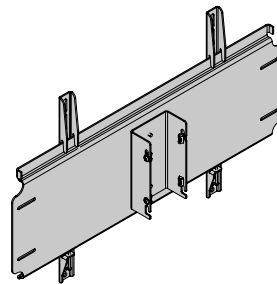

Seam Mounted
 OB1CDPSMB

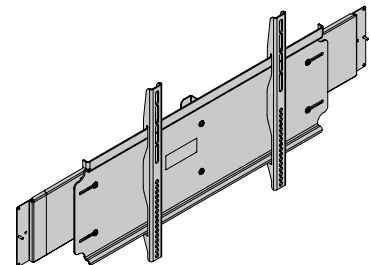

Product Height Guide

Recommend Minimum Building Clearance Heights for Any Campers & Dens

Sprinkler height: 9'3" (sprinkler covered space)

These are general guidelines and should be clarified/approved by local Authorities Having Jurisdiction (AHJ) as requirements are dependent upon specific building details.

Sprinkler Height: 9'3"

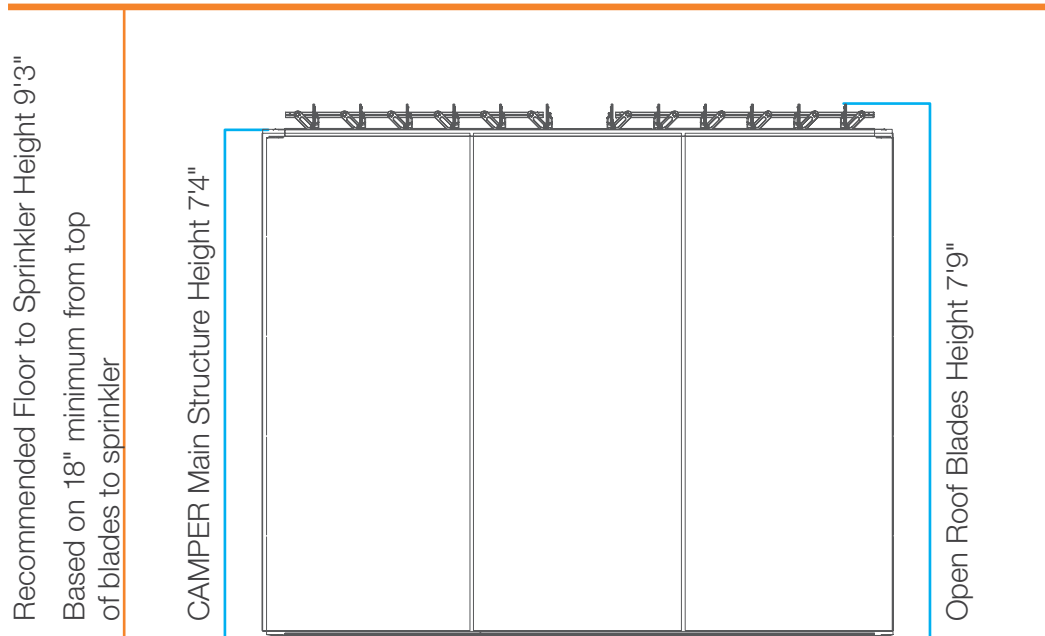

Campers & Dens: Camper Structure

Camper Service Hoop

Every camper comes integrated with lighting, ventilation and power.

CD02 max. weight: 1,556 lbs

CD05 max. weight: 1,941 lbs

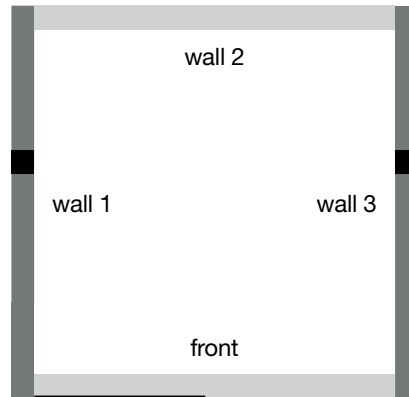

By default, the vertical closest to the door is the switch side. This can be reversed during installation.

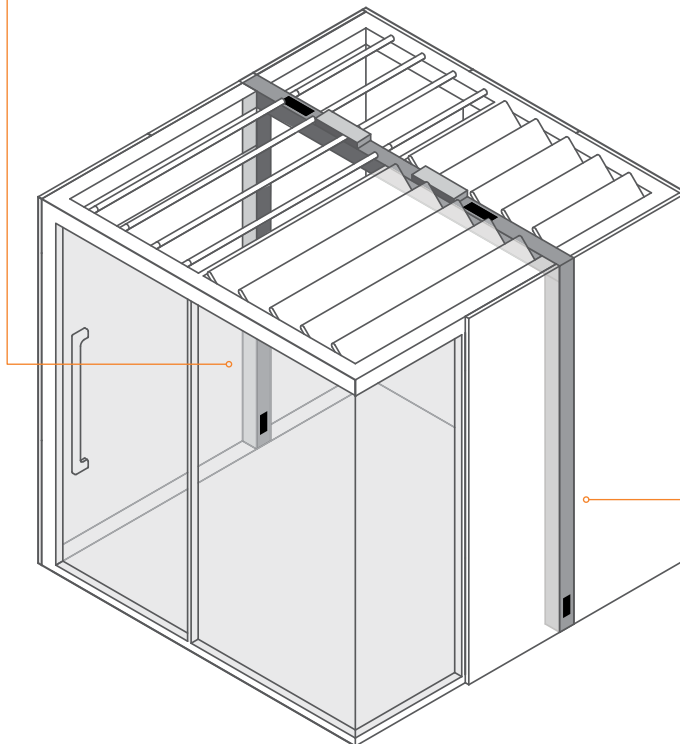

By default, the vertical opposite of the door is the power side. This can be reversed during installation.

Campers & Dens: Accessories

Application Rules

All accessories must be attached to a camper.
Application rules are valid for both CD02 and CD05.

Application Rules

Kinks can be applied to the front.
Handedness matches that of the door opening direction.

Application Rules

Cabins can only be applied to wall 2 (back),
and only when no glass is present.
Cabin offering includes optional lighting and
a choice of solid or slatted roof.

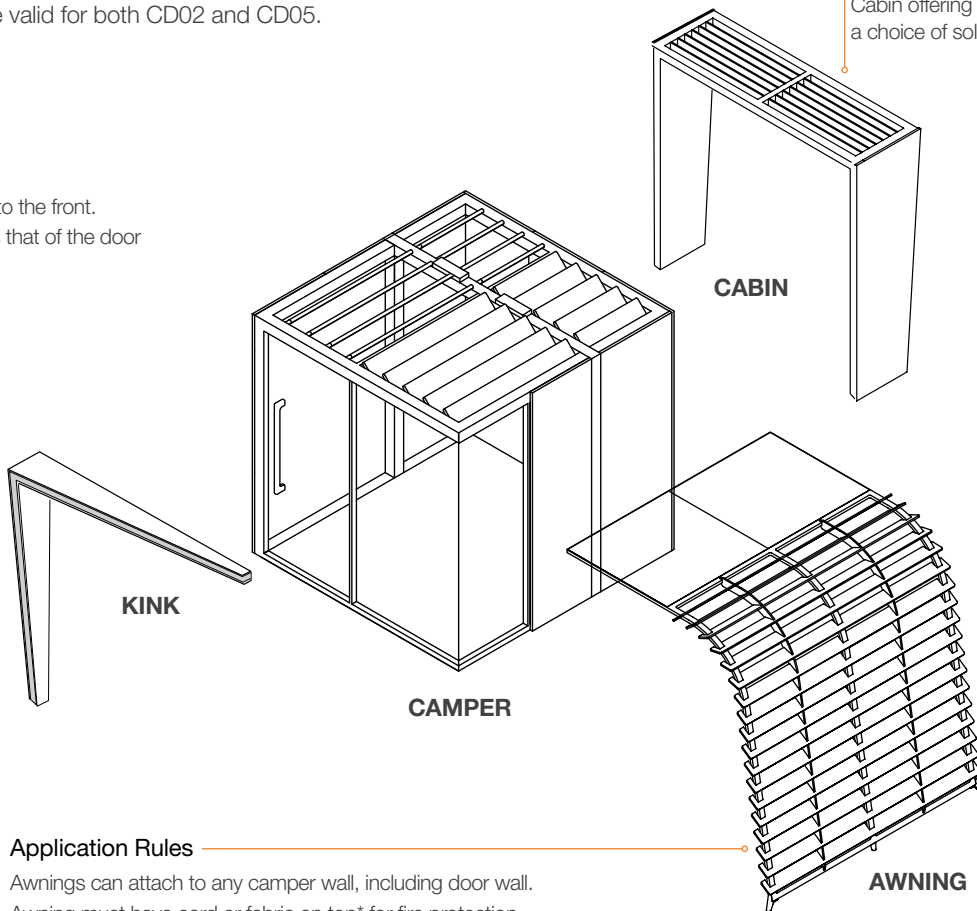

Application Rules

Awnings can attach to any camper wall, including door wall.
Awning must have cord or fabric on top* for fire protection.
Awning can hold 40 lbs (i.e. for a light fixture)

Full Finish

* Fabric and cord can be full or split finish.

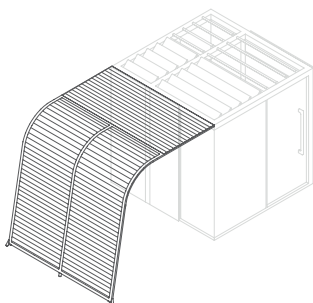

Split Finish

* Plywood and felt can only be side of split finish.

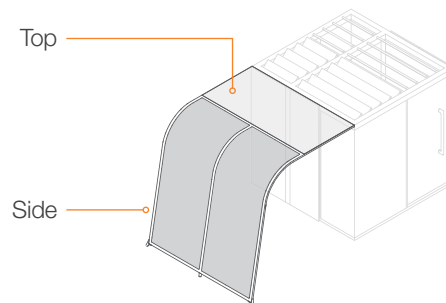

Campers & Dens: Accessories

Hacking

Hacking can be installed on the side walls (wall 1 and wall 3) as long as it doesn't share a wall with the kink or awning.

Can be installed on left- or right-hand depending on the door orientation.

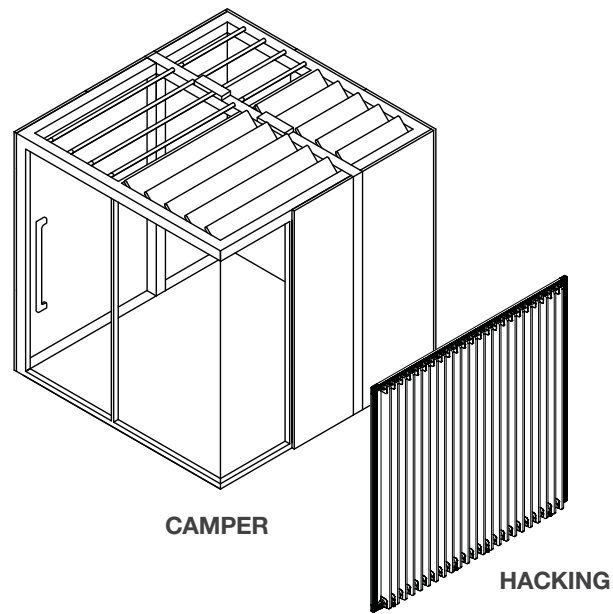

Hacking Styles

Up to Glass Corner

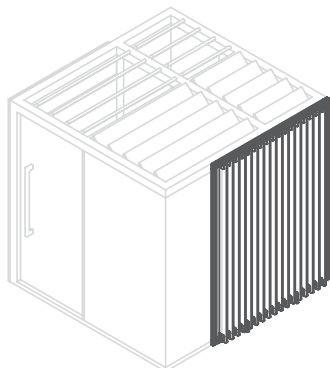

Full Camper Depth

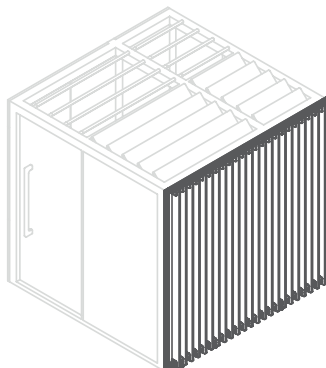

Around Corner

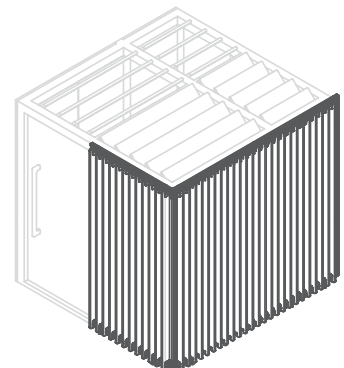

Campers & Dens: Furniture Applications

Tables

Integrated tables can be used inside and outside the camper. They may be mounted to the hoop or centered on the panel.

Panel mounted tables can only be mounted on center panel(s), not on corner panels.

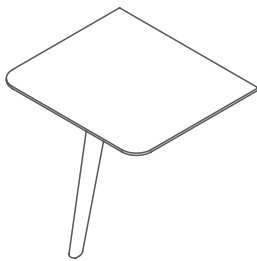
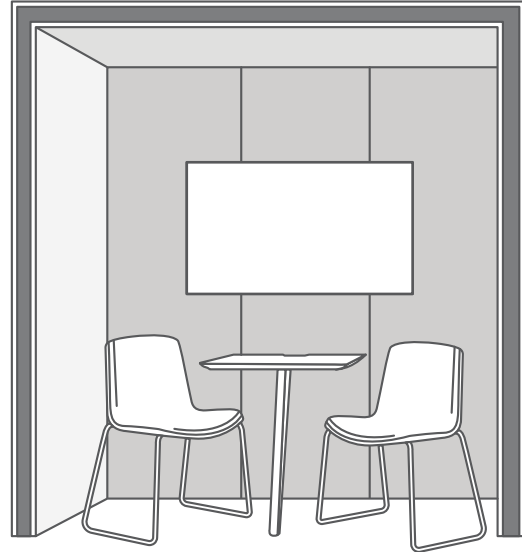

OB1CDWT01
Panel Mounted Table
29.6"H x 28.3"W x 25.8"D

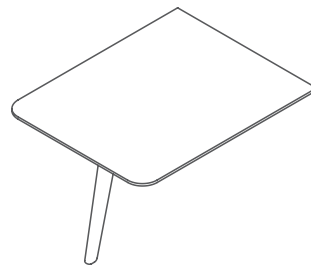

OB1CDWT02
Panel Mounted Table
29.6"H x 28.3"W x 35.4"D

Panel Mounted Table Arrangements

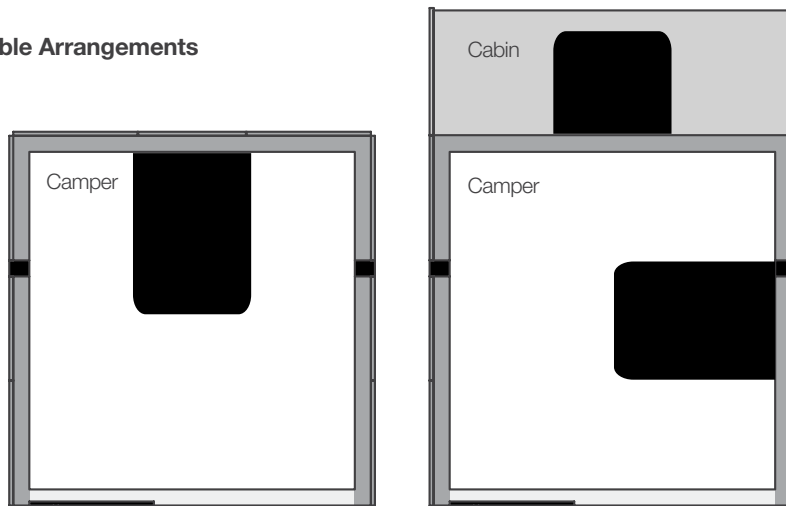

* Panel Mounted Table shown in CD02 Campers

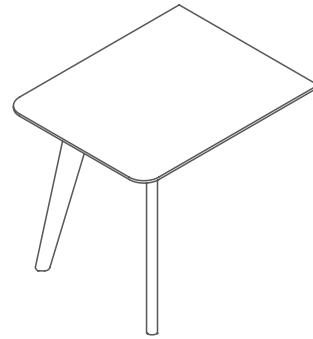
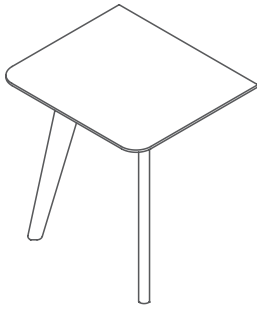

OB1CDWT02

Hoop Mounted Table

29.6"H x 28.3"W x 35.4"D

Hoop Mounted Table Arrangements

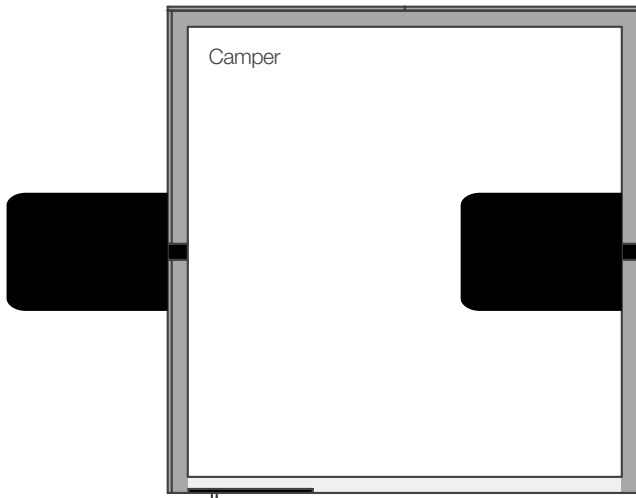

* Hoop Mounted Table shown
in CD05 Campers

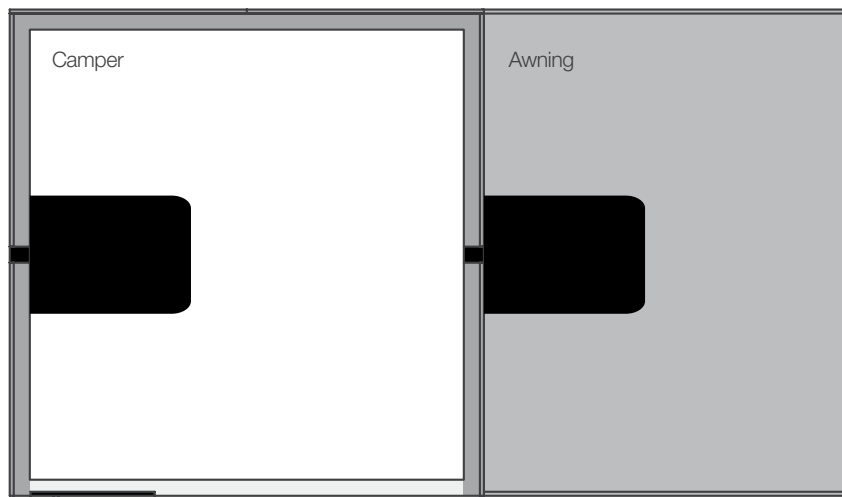

Campers & Dens: Furniture Applications

Monitor Mounting Brackets

Panel Mounted Monitor Bracket

OB1CDFHMB

Maximum monitor weight : 100lbs

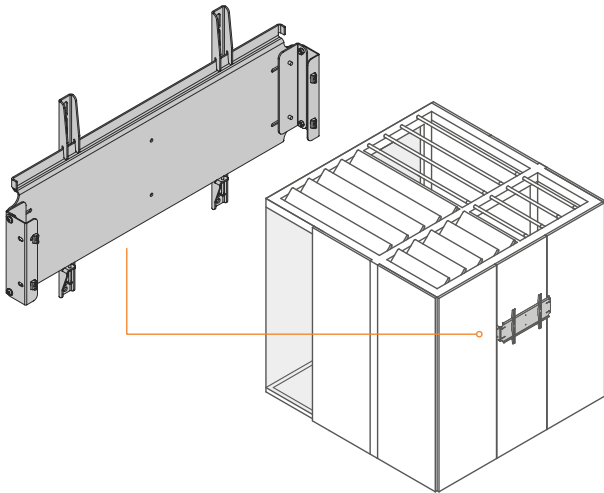

Hoop Mounted Monitor Bracket

OB1CDHMMBS

Maximum monitor weight : 100lbs

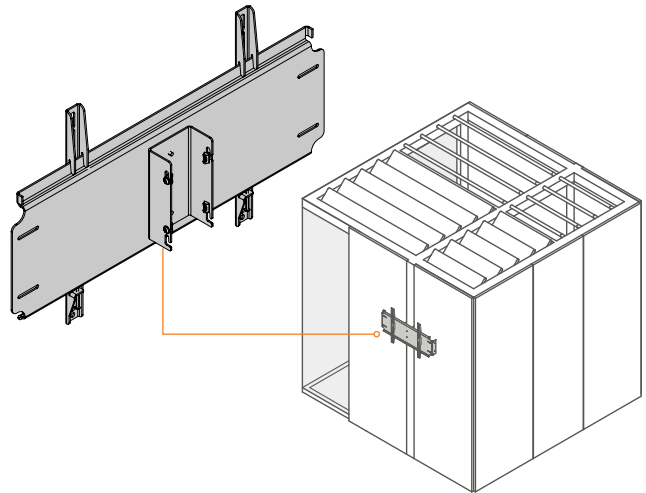

Seam Mounted Monitor Bracket

OB1CDPSMB

Maximum monitor weight : 100lbs

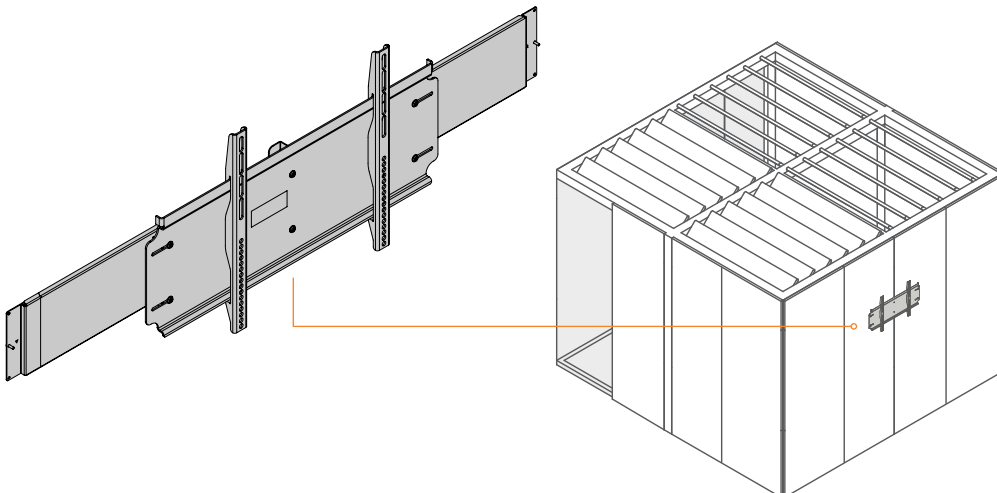

Campers & Dens: Furniture Applications

Monitor Mounting Brackets

Application Rules

Monitor brackets can be used inside or outside of any size camper in specific mounting positions on the hoop, seam or panel. The brackets can be mounted anywhere vertically on the hoop, seam or panel.

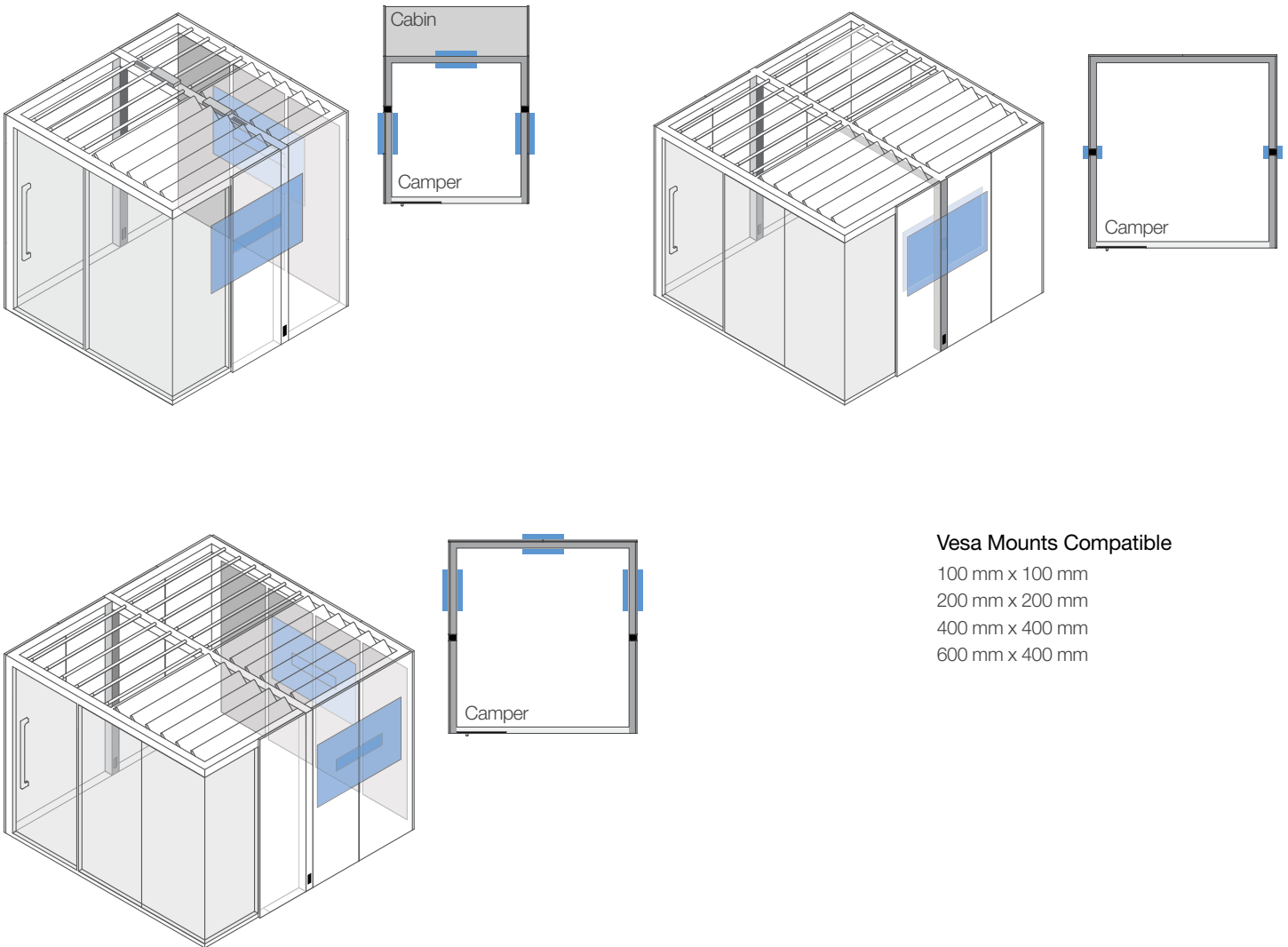

Vesa Mounts Compatible

- 100 mm x 100 mm
- 200 mm x 200 mm
- 400 mm x 400 mm
- 600 mm x 400 mm

Section 3

User Features

User Control Module

Introduction

Every camper comes fitted with a control module as standard. This is always situated on the vertical hoop and allows users to manually manage the lighting, ventilation and roof settings within the camper.

Upon entering the camper, a PIR (passive infrared) sensor in the roof will automatically activate the default settings for the lighting and ventilation and close the roof.

Although the user control module allows users to adjust lighting levels and airflow rate, the fully automated system allows users to simply enter the camper and start their meeting or work session without the need to interact with the control module in any way.

Control Module Layout for Campers

The functions on the camper's control module are split into three distinct areas:

- 1. Lighting Scene Levels** (5 buttons) in the top section.
- 2. Ventilation / Airflow Rate** (3 buttons) on the lower left.
- 3. Opening Roof Control** (3 buttons) on the lower right.

There is also a single 'auto refresh' button which will open the roof by 20% and increase air flow rate to 100% level for a 1 minute period, after which the roof will close and the ventilation will revert to its previous setting.

Lighting



Refresh Opening Roof + Max Airflow

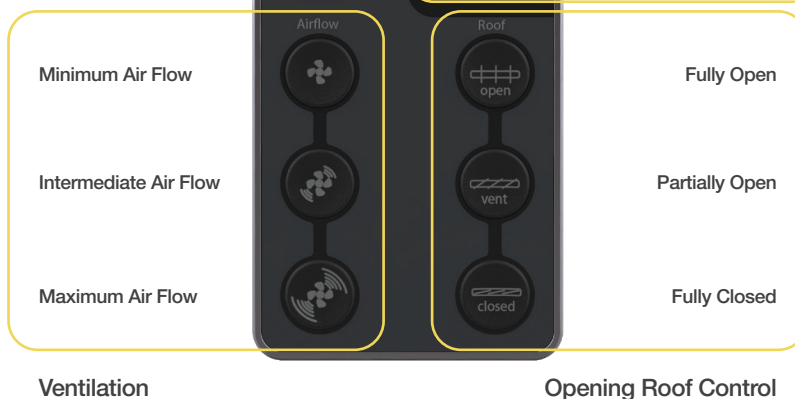

Height Dimensions

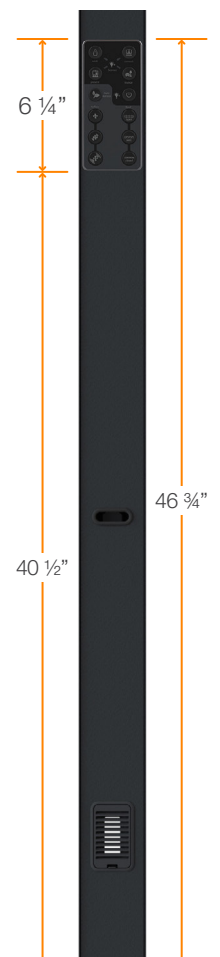

User Control Module

Lighting Levels Inside Camper

The lighting functions on the camper's control module allow users to select from 1 of 4 pre-set 'scenes' that tune the lighting levels inside the camper to suit specific work scenarios:

1. **Work** (default) / a brightly lit general meeting scenario.
2. **Connect** / specifically working with a screen for video conferencing.
3. **Present** / working with a screen for presenting inside the camper.
4. **Lounge** / more subdued lighting levels for more relaxed working.

- A quick press of the relevant button selects that lighting scene.
- Press and hold to dim the lights down within the scene setting.
- Press and hold again to dim the lights up again within the scene setting.
- A 5th button can turn all the lights off and on again.

Lighting



User Control Module

Ventilation / Airflow Rate into Camper

The ventilation functions on the camper's control module allow users to select from three distinct levels of fan output from the system.

1. **Low** / this is the default setting and will deliver a minimum of 10 air changes per hour. To ensure the air inside the camper is always being refreshed (to avoid an excessive build up of heat and CO₂) the system cannot be set any lower or turned off completely.
 2. **Medium** / around 75% of the system's maximum capacity.
 3. **Boost** / 100% of the system's capacity.
- A quick press of the relevant button selects that ventilation level.
 - **Note:** To ensure proper ventilation, it is not possible to drop the ventilation below the 'low' level to maintain a minimum of 10 air changes per hour at all times.

Auto Refresh

The 'auto-refresh' button will open the roof by 20% and increase airflow rate to 100% level for one minute, after which the roof will close and the ventilation will revert to its previous setting.



User Control Module

Opening Roof Control

In addition to having the camper roof fully closed for acoustical privacy, the camper can also be used with the roof blades fully or partially open.

There are 3 buttons giving the following options:

1. Fully Open
2. Partially Open
3. Fully Closed

When users exit the camper, the roof blades will automatically open after a set period of time, and will remain open while unoccupied as a fire safety feature (for internal sprinkler coverage).



Opening Roof Control

Section 4

Acoustics

Acoustics



Orangebox's interior architecture team have worked closely with independent acoustic consultants for many years - both to provide acoustic input and insights in the product development process and to carry out external acoustic verification of the final design.

Acoustic Testing

There is no single global definitive acoustic test for pods but there are a range of tests that can be carried out to provide guidance on the quality of a pods' acoustic performance.

Test Results

Test 1: Reverberation Time ('RT60' time measured in seconds)

Reference Number: ASTM E2235

Description: Indicates the level of acoustic comfort in a camper along with a measure of speech clarity i.e. elimination of echo makes it easier to comprehend a conversation.

Results: Reverberation was measured at less than **0.37 secs.**

Test 2: Speech Transmission Index (measured between 0 and 1)

Reference Number: IEC 60268

Description: Indicates how easy it is to understand, from outside the camper, conversations that are taking place inside the camper, on a scale from 0 to 1.

Results: Speech Transmission Index measured **0.15.**

Test 3: Noise Isolation Class (NIC)

Reference Number: ASTM E336

Description: Measures total sound insulation performance between two rooms after full construction.

Results: Reduction of **31-32 dB.**

Additional notes:

Per BIFMA Pods guidance for Pods, Sound Transmission Class (STC) is a component test and not appropriate for a fully enclosed pod.

Some variation can be expected depending on the panel material selections and glass configurations. Test results are for a CD02 "D" glass configuration with fabric panels.

Acoustic Design Features

Gap Elimination / Design Detailing

From the experience gained developing previous pod generations, the design team have focused on minimizing gaps and detailing every interface and joint with overlaps and seals. Special attention has also been given to improving the sliding glass door seals, an area that is often the weakest point of a camper room.

Speech Intelligibility Reduction vs. High Sound Blocking

Most importantly the design team have focused acoustic solutions not only towards sound blocking but also low speech transmission levels which is equally important.

Acoustic Performance

Other Factors

While empirical sound measurements provide a good indication of overall acoustic effectiveness of a camper there are other factors that can have a significant impact as well.

Type of activity inside the camper and ambient noise level outside the camper in the general workspace:

The four scenarios shown below consider the type of activity inside the camper (quiet solo working or active team meeting) and how noisy the general workspace is outside the camper.

1. High / High



High Ambient Noise Level Outside the Camper



3. Low / High



Low Ambient Noise Level Outside the Camper

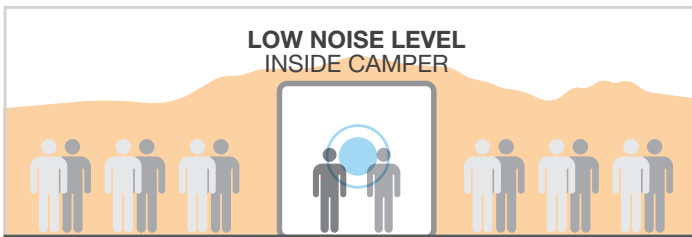

High Ambient Noise Level Outside the Camper

2. High / Low



Low Ambient Noise Level Outside the Camper

4. Low / Low



Acoustic Performance

Other Factors

Position and orientation of a camper to where people are working outside the camper:

Attention should be given to the proximity of people working outside the camper – This is especially important if these people will be working outside the camper for long periods of time / permanently, or if the workspace is particularly quiet.

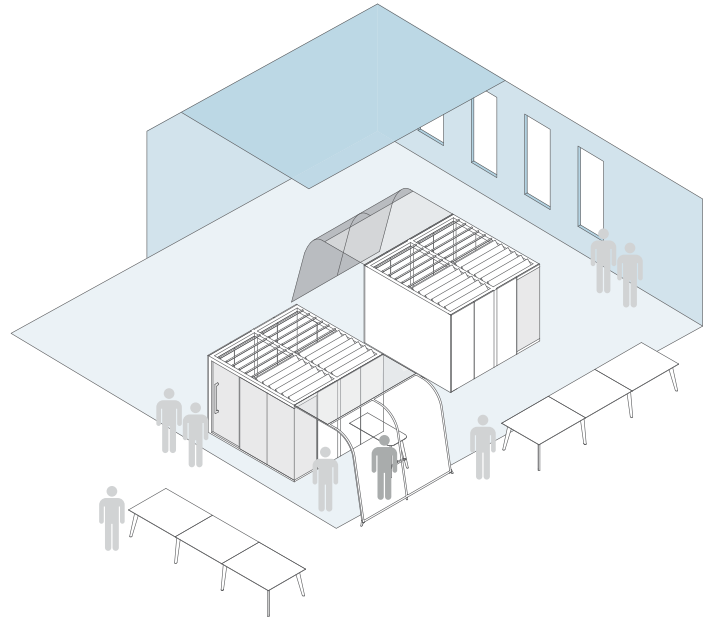

General building construction around the camper and proximity of ceilings and walls to the camper:

Proximity of hard surfaces such as brick walls, concrete floors, low ceilings, large glass windows can negatively impact the acoustic performance of a camper – conversely carpeted flooring and high ceilings can help overall acoustic performance.



Section 5

Integrated Services: Fire Safety

Internationally Patented Opening Roof Design

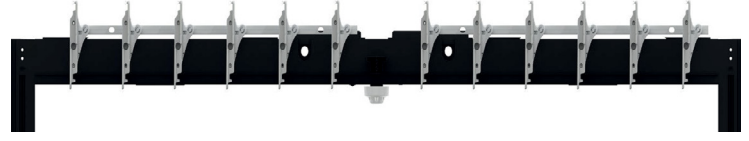

In 2014 Orangebox introduced the world's first opening roof design on its Air3 pod product collection which brought a new level of innovation to the flexible pod sector.

This unique, patented design consists of rotating louvers, driven by two actuators, connected to enable louvers to open and close simultaneously. The patented design allows for best-in-class functionality in fire emergencies.

In the Event of a Fire

Stage 1

If a fire starts in the camper it will be detected by the heat detector or smoke detector.

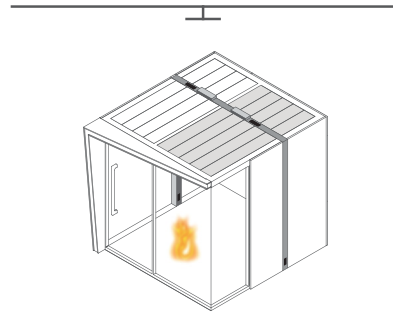

Stage 2

The detectors immediately cut power to the camper releasing the spring in the actuators which drives the louvers open in just 8 seconds.

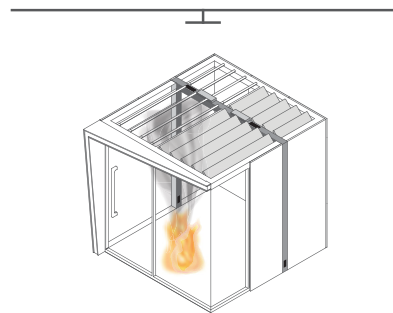

Stage 3

The open roof allows the smoke of the fire to release and activate the closest sprinkler heads.

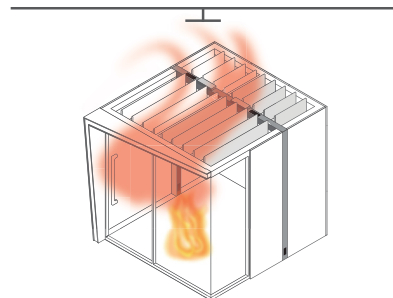

Stage 4

The open area allows enough water ingress from the sprinklers to control the size and spread of the fire within the camper.

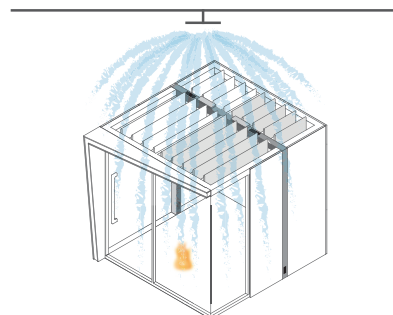

A Multi-Layer Safety System

The opening roof solution has been specifically developed as a multi-step safety system and the default position of the roof is open to allow building sprinkler water ingress.

The safety system works by cutting the power to the actuators, releasing the spring in the actuators which drives the louvers open in eight seconds.

The roof opens if any of the following events happen:

- The Primary Smoke Detector detects smoke.*
- The Secondary Heat Detector reaches 151°F
- The power to the camper is cut
- The Smoke Detector or Heat Detector is partially or completely removed

Campers can be connected to the Building Management System. Reference the Assembly Directions for further instruction and consult with your local Fire Authorities for all approvals.

* Canadian orders will have a primary heat detector which opens at 135°F.

Smoke Detectors and Heat Detectors are UL Listed.

Smoke Detector manufacturer: Hochiki, Model: NS4-221

Heat Detector (installations in Canada) manufacturer: System Sensor, Model: 5621A

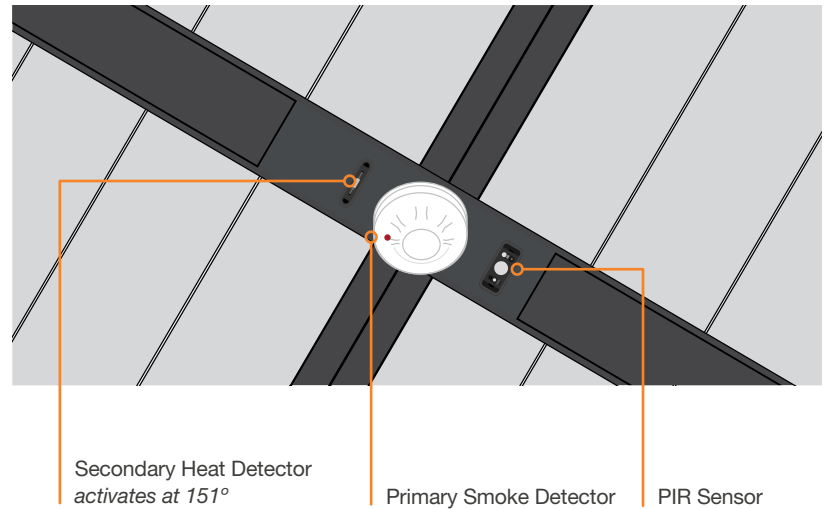

Secondary Heat Detector (Fusible Link) – 151°F

Manufacturer: Cantherm, Part # DF66S



Before fusing off

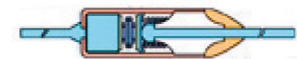

After fusing off



Sprinkler Positioning & Obstructions

The opening roof has been designed to create a minimum 70% open roof area to conform to NFPA 13 standards for sprinkler systems mounted above an open grid ceiling system. Formal review with Authorities Having Jurisdiction (AHJ) is required.

The roof louvers are available in Seagull 7243.

CD02 Campers

70.5% Open Area

Hoop width: 3-5/8"

Hoop length: 7'4"

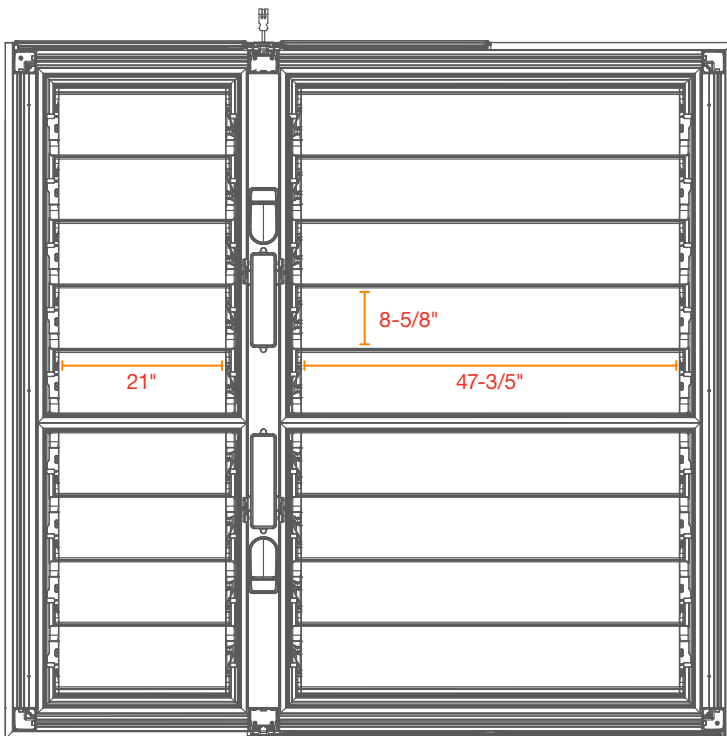

Sprinkler Positioning & Obstructions

The opening roof has been designed to create a minimum 70% open roof area to conform to NFPA 13 standards for sprinkler systems mounted above an open grid ceiling system. Formal review with Authorities Having Jurisdiction (AHJ) is required.

CD05 Campers

70.5% Open Area

Hoop width: 3-5/8"

Hoop length: 7'4"

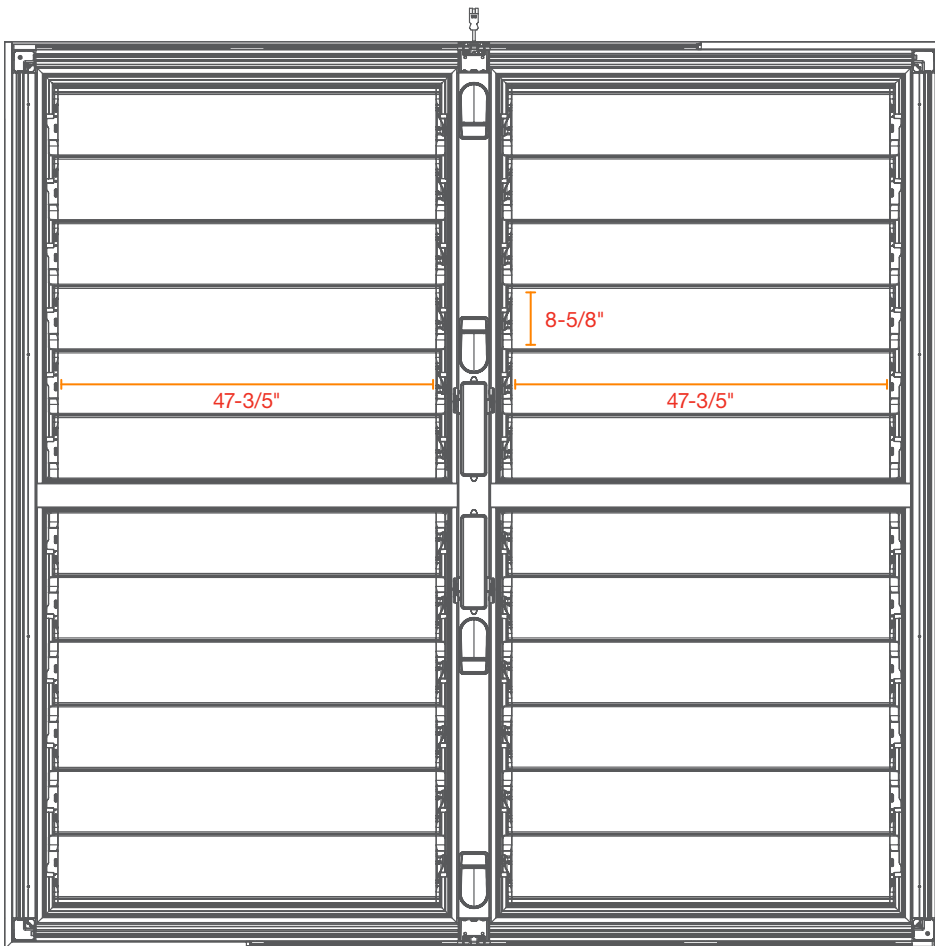

Roof Louver Actuators

Details

Actuators:
Safety system opening in eight seconds from detection

The actuators chosen are UL approved, IP54 rated, and have an 'emergency spring' which will open in eight seconds in the event of an emergency.



Direction of Rotation:	Can be selected by mounting L / R
Service Life:	Min. 60,000 emergency positions
Protection Class:	Extra low voltage UL Class 2 Supply
Degree of Protection:	IP54 NEMA2, UL Enclosure Type 2
EMC:	CE according to 2004/108/EC
Certification:	cULus according to UL 60730-1A and UL 60730-2-14 and CAN/CSA E60730-1:02 Certified to IEC/EN 60730-1 and IEC/EN 60730-2-14
Maintenance:	Maintenance-free

How Campers & Dens Works With the Building

The innovation in this solution is in maintaining freedom and flexibility of the campers from the building infrastructure, with the potential for no sprinkler integration required or connection to the fireboard.

The integrated smoke and heat detectors are connected to the roof louvers to ensure they are in the fully open position in emergency situations.

What about fire strobes?

Campers can be specified in three standard glass configurations - all variations have large glass wall elements which readily allow viewing external visual alarms.

Depending on the importance of this factor you can specify campers with greater amounts of glass panelling.

Fire strobes can be installed inside the camper if required.

What about audible alarms?

The campers have a qualified acoustic performance but are not soundproof and therefore a fire alarm set to 75 / 80dB is audible inside the camper (NFPA 72 - 15dB higher than the average ambient sound e.g 60dB). On site project specific testing is recommended.

Is there an option to connect a camper to the building?

Yes, the camper's integrated smoke and heat detectors can be linked to the main building fire system.

Can the campers have an integrated sprinkler?

If sprinkler integration is required, it is possible to disengage a single roof blade and install a sprinkler head through the roof blade. A certified sprinkler installation provider is responsible for carrying out this integration work.

Section 6

Integrated Services: Ventilation

Ventilation

An efficient ventilation system is essential to ensure good air flow, control CO₂ levels, and regulate temperature inside the camper during use.

The ambient temperature in a workspace should be assessed as well as any potential effects from solar gain if a camper is positioned near to the edges of buildings that have a substantial amount of exterior building glazing. This is especially relevant to camper variants that have a greater percentage of glass panels.

In particular the camper air inlet vents, both inside and outside, should not be blocked in any way to ensure the camper's ventilation system is operating efficiently.

Campers should be used with the appropriate number of people inside in relation to the overall size of the camper.

The ventilation system has been developed to meet BIFMA and ASHRAE 62.1:

Business & Institutional Furniture Industry Guidance (BIFMA) for Pods (est. 2021) states that an automatic fan(s) with an occupancy sensor, or other automated switching device, or a continuous fan, is required to ensure the ventilation rate while the camper is occupied.

ASHRAE 62.1 (2019) states that a camper shall operate with minimum ventilation rates and other measures intended to provide indoor air quality (IAQ) that's acceptable to human occupants and that minimizes adverse health effects.

A camper shall operate at a minimum air change rate of 10 air changes per hour when occupied.

CD02 Camper Air Flow / Air Changes

Low: 12.8 ACH
 Medium: 16.1 ACH
 High: 20.1 ACH

Air changes per hour at the nominal 55% fan setting: 12.8

The ventilation system has been developed to create a low noise solution.

Ventilation System Noise

(inside the camper)

Low: 41.8 dBa
 High: 49.2 dBa

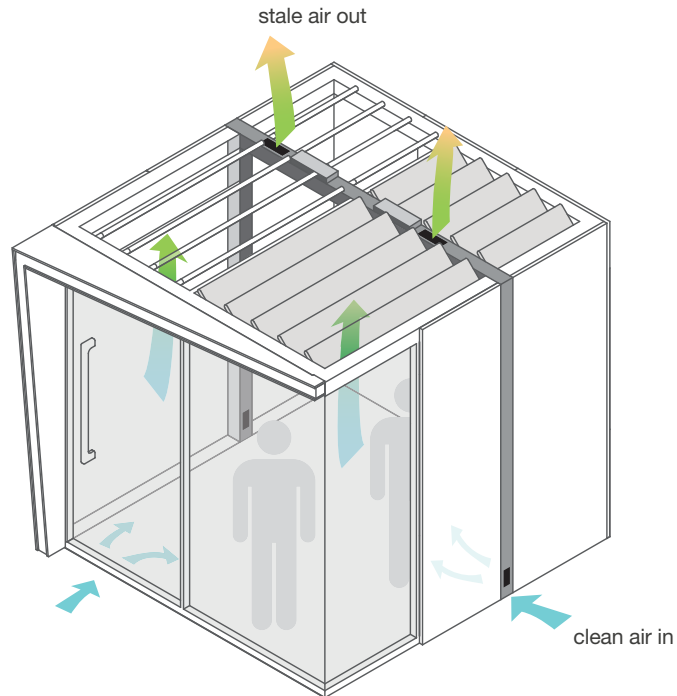

CD05 Camper Air Flow / Air Changes

Low: 12.1 ACH
Medium: 15.8 ACH
High: 18.2 ACH

Air changes per hour at the nominal
55% fan setting: 12.8

The ventilation system has been developed to create
a low noise solution.

Ventilation System Noise

(inside the camper)

Low: 41.8 dBa
High: 49.2 dBa

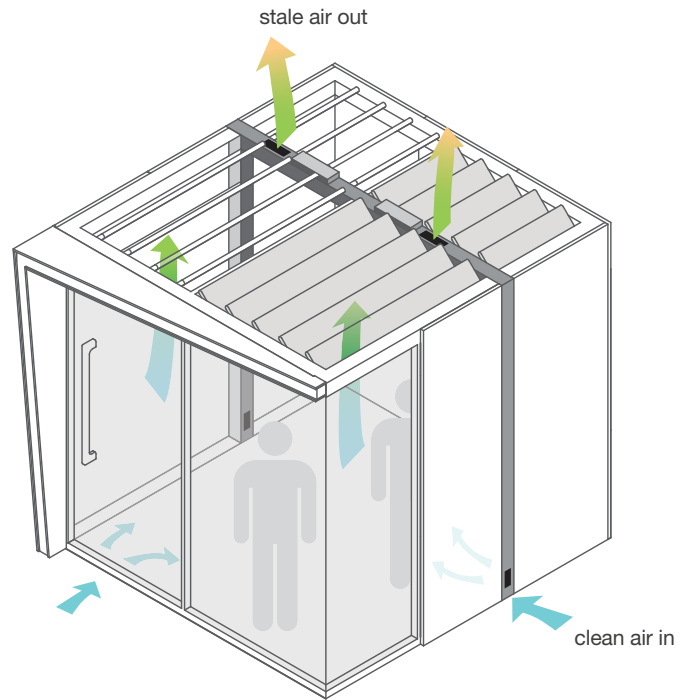

Ventilation

Day-to-Day Function

Static Mode

When the camper is unoccupied, the default fan setting is off.

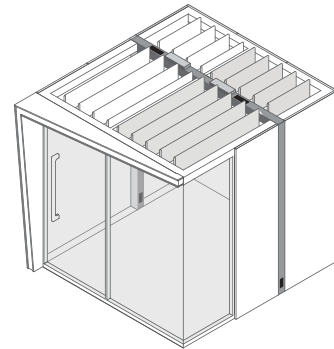

In Use Mode

When entering the camper, the Passive Infrared sensor (PIR) senses movement, automatically closes the roof and turns the fan on.

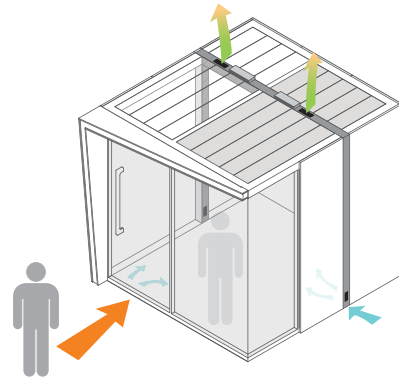

Meeting Over Mode

When unoccupied, after 10 minutes, the PIR sensor opens the roof blades and turns the fan off.

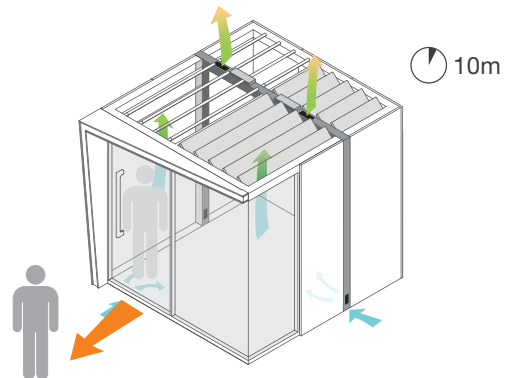

Section 7

Integrated Services: Lighting

LED Light Levels (Lux)

Integrated into the main service hoop of the camper, our lighting system uses efficient LEDs to deliver high output, low energy consumption lighting that's maintenance-free.

The lighting will turn on automatically via the pod's PIR sensor when a person enters the pod and turn off again after exiting.

Lighting levels can be manually changed with the control module to suit the type of work activity.

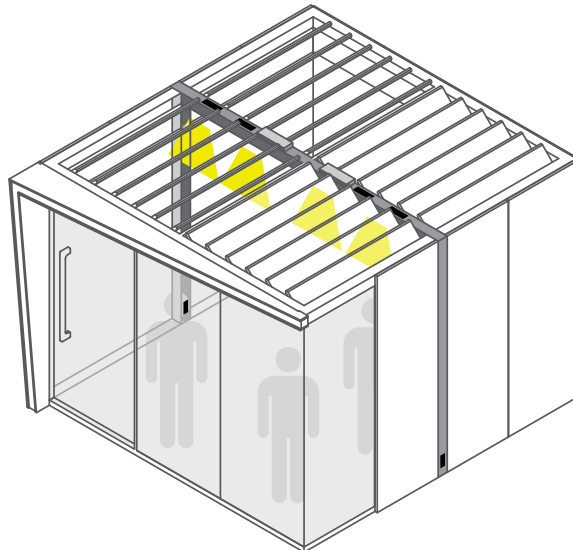
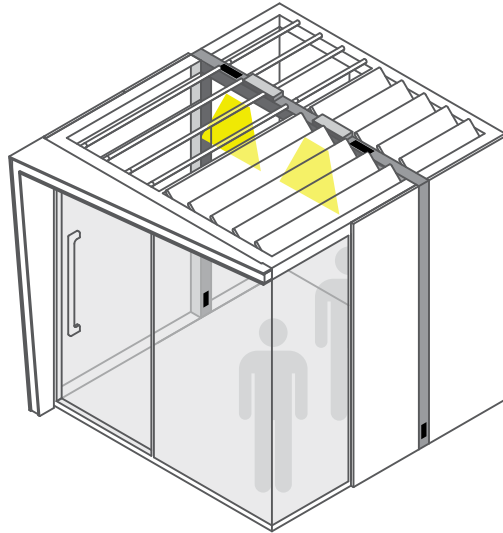

CD02 Lux Levels

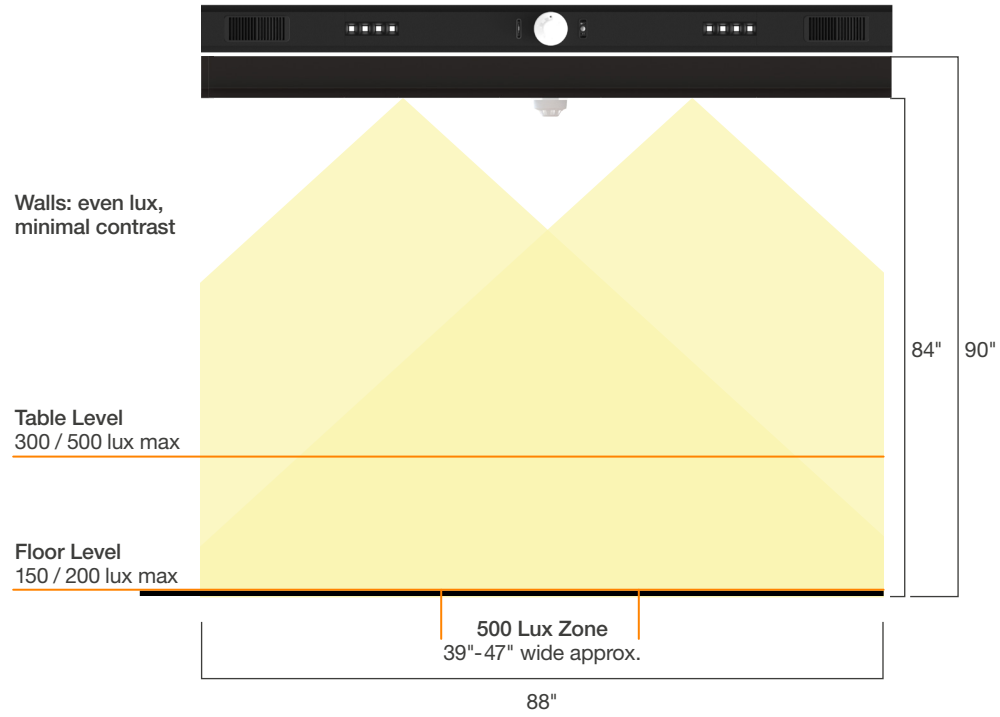

CD05 Lux Levels

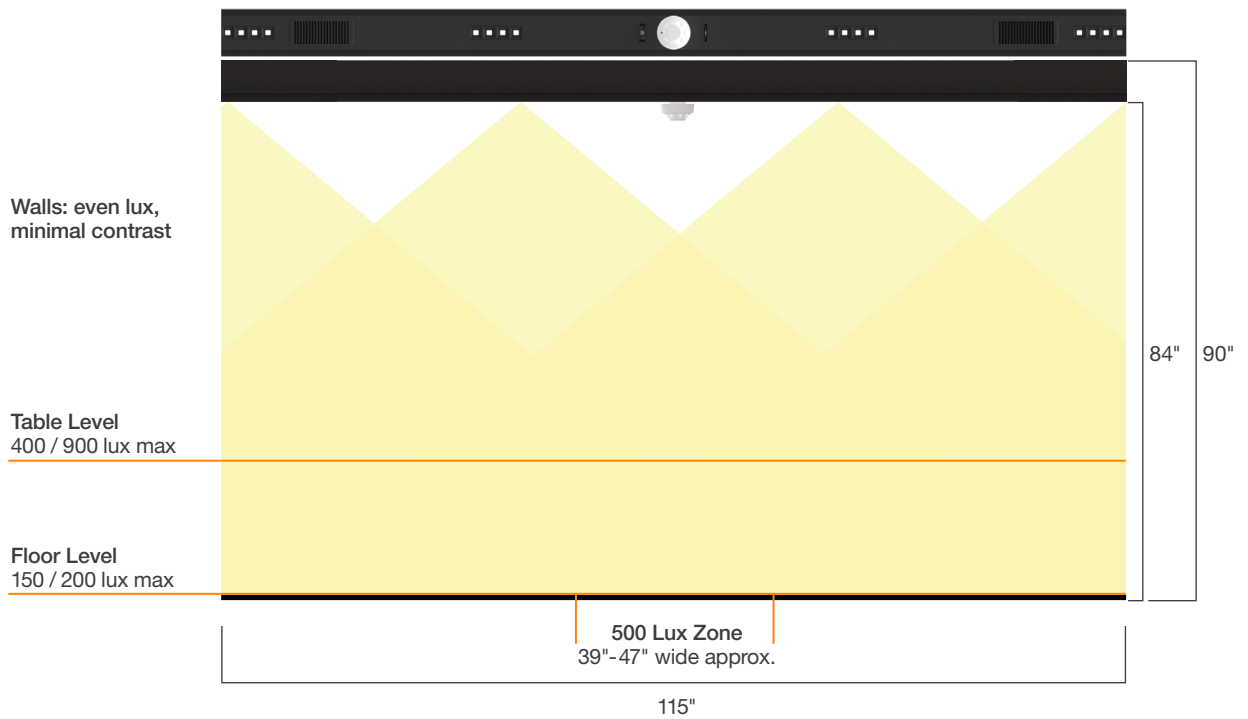

CD02 Camper LED Lighting

Default Lighting Scenes (on user control module) 2 x 4 LED Modules

Each LED Module is 4000k color temperature, with a target uniformity of 0.6 U_o, and CRI 80+

Work (Meet)

Aim: Even light distribution for general work / meeting conditions (i.e. around a table or at a workstation)

Delivering **500 lux** at table height.

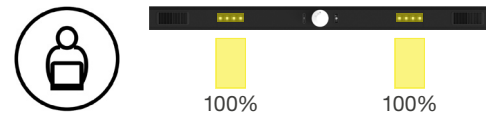

Connect

Aim: Optimized light conditions for video conferencing.

Delivering max. **400 lux** at head height.

A light ration of 2:1 on faces vs. the background directly behind is desirable. Bleaching or whitewashing the walls is to be avoided to ensure good facial recognition.

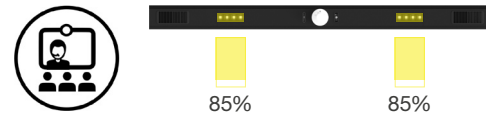

Present

Aim: Optimized light conditions for screen-based presentations.

Delivering max. **250 lux** at table height for note writing.

Lowers outer lights to reduce light on screen and any reflected highlights from the opposite wall.

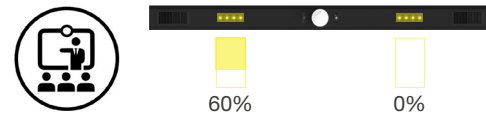

Lounge

Aim: Light conditions for a camper being used with informal seating only or when the user wants more subdued general lighting which they may choose to supplement with the optional floor lamp or their own task lighting (e.g. desk lamp) or additional 'mood' lighting (e.g. standard lamp).

Delivering **150 lux** at desk height.

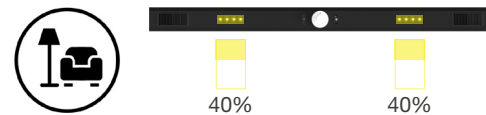

CD05 Camper LED Lighting

Default Lighting Scenes (on user control module)

4 x 4 LED Modules

Each LED Module is 4000k color temperature, with a target uniformity of 0.6 U_o, and CRI 80+

Light 1
Zone 1
↓

Light 2
Zone 2
↓

Work (Meet)

Aim: Even light distribution for general work / meeting conditions (i.e. around a table or at a workstation)

Delivering **500 lux** at table height.

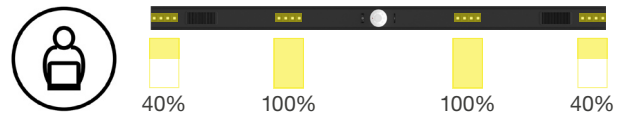

Connect

Aim: Optimized light conditions for video conferencing.

Delivering max. **400 lux** at head height.

A light ration of 2:1 on faces vs. the background directly behind is desirable. Bleaching or whitewashing the walls is to be avoided to ensure good facial recognition.

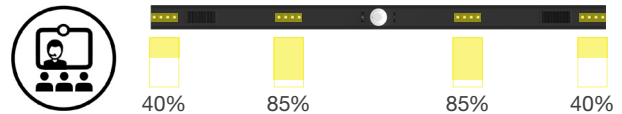

Present

Aim: Optimized light conditions for screen-based presentations.

Delivering max. **250 lux** at table height for note writing.

Lowers outer lights to reduce light on screen and any reflected highlights from the opposite wall.

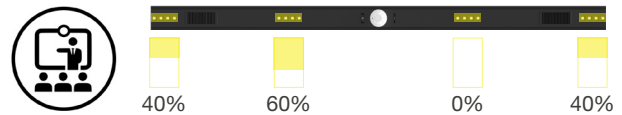

Lounge

Aim: Light conditions for a camper being used with informal seating only or when the user wants more subdued general lighting which they may choose to supplement with the optional floor lamp or their own task lighting (e.g. desk lamp) or additional 'mood' lighting (e.g. standard lamp).

Delivering **150 lux** at desk height.

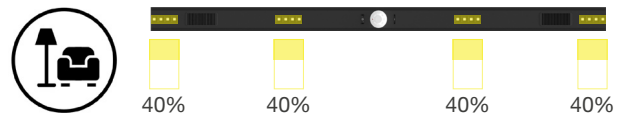

Lighting

Day-to-Day Function

Static Mode

When the camper is unoccupied, the lights default position is off.

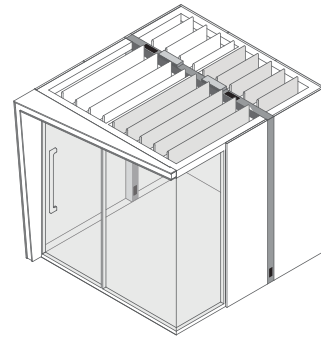

In Use Mode

When entering the camper, the Passive Infrared sensor (PIR) senses movement and automatically turns the lighting on to the Work setting.

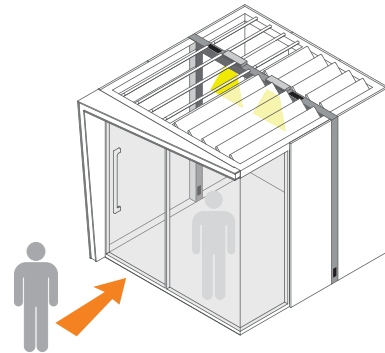

Manual Mode

When the camper is occupied, the control panel can be used to adjust the lighting to any of the four settings: Work, Lounge, Connect, Present.

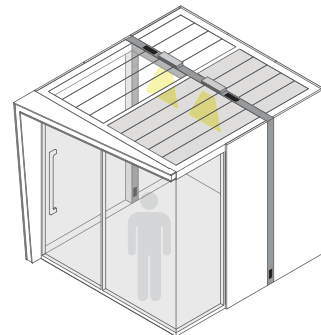

Meeting Over Mode

When unoccupied, after 5 minutes, the PIR sensor turns the lights off.

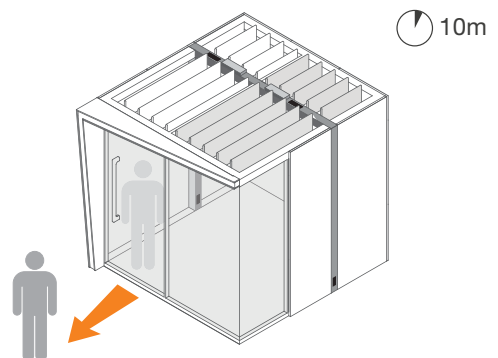

Camper Cabin Optional LED Lighting

LED Lighting Modules

2 LED Modules

Module dimensions: 21-1/8" x 0.5"

Power: 8W per module

Color temperature: 3000K with 90+ CRI

* 2 LED modules for CD02; 4 LED Modules for CD05.

* Power lead requires additional floor box/power connection.
The cord can be routed to exit from either the left or right wall of the cabin. It's 6 feet long on both sizes.



Section 8

Integrated Services: Power/Electrical

Camper: Integrated Power

Camper Integrated Power

Standard Inside Power - 'Power' Side

- Standard 3 power inside camper, 'Power' side
- Optional 2 power / 1 USB-a + USB-c

Optional power placements

- 'power' side - Exterior
- 'switch' side - Interior
- 'switch' side - Exterior

All additional power locations are only available in the standard 3 power configuration only.

Each additional power location needs to be connected to a nearby building power.

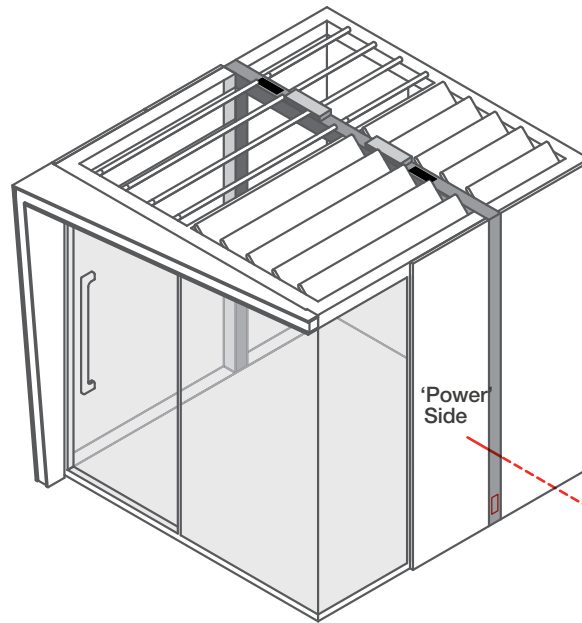

Configurations

Standard

Optional

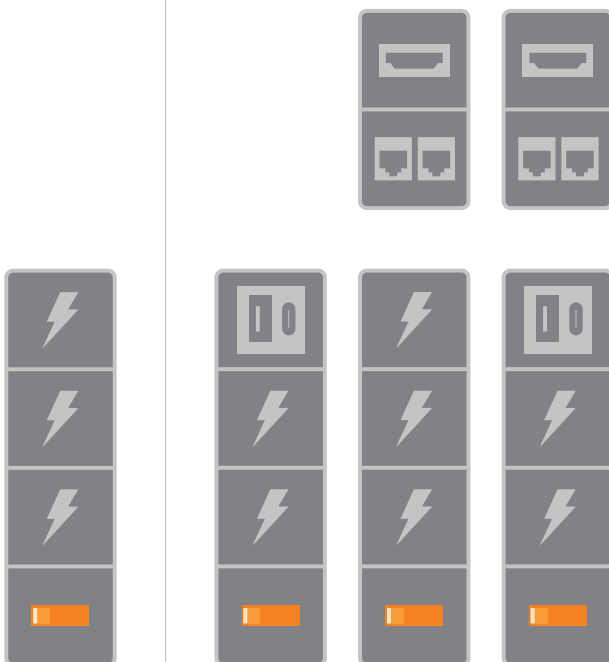

Key

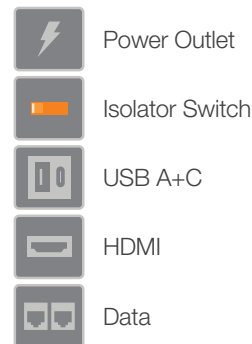

Height Dimensions



Connecting a Camper to Power

Main power to the camper is always fed into the “power side” vertical hoop but can be routed in one of three ways:

1. Internal floor-box
2. External floor-box or wall socket
3. External ceiling-fed power outlet*

The campers' vertical hoop assemblies have been designed to allow power and data cables to be routed internally, through the cavities in both the inside and outside channels of the hoop.

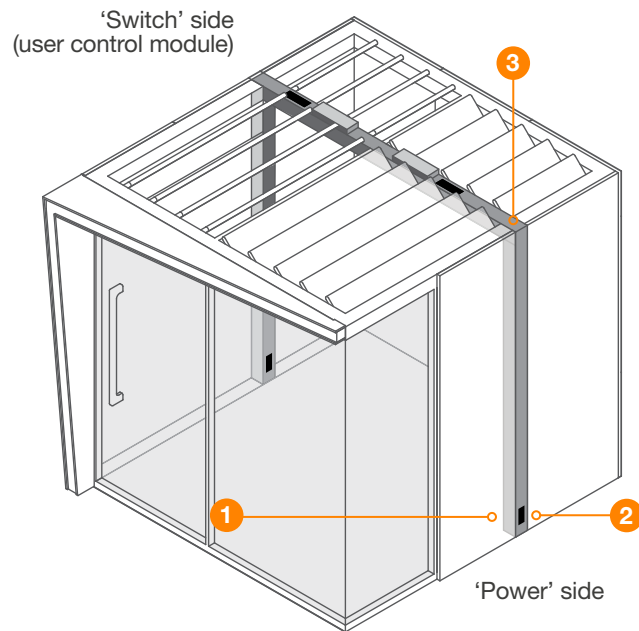

* Power cord is approximately 9' from the camper when exiting from the bottom of the hoop.

* External ceiling feed power results in a shorter cord.

Monitors and scheduling device cords can be routed between panels, through panels, and through the hoop. For more details, visit ussupport.orangebox.com.

A single standard plug is used to power the camper.

The floor box or wall socket should be within the standard lead length of the camper power cord.

There is not an option to hardwire the Campers.

DO NOT overload socket receptacles.

DO NOT plug any of the following into socket receptacles:

- Vacuum cleaners
- Heaters
- Air conditioning units
- Extension cords/leads
- Other high amperage equipment

Connect only computer equipment & associated peripherals into socket receptacles.

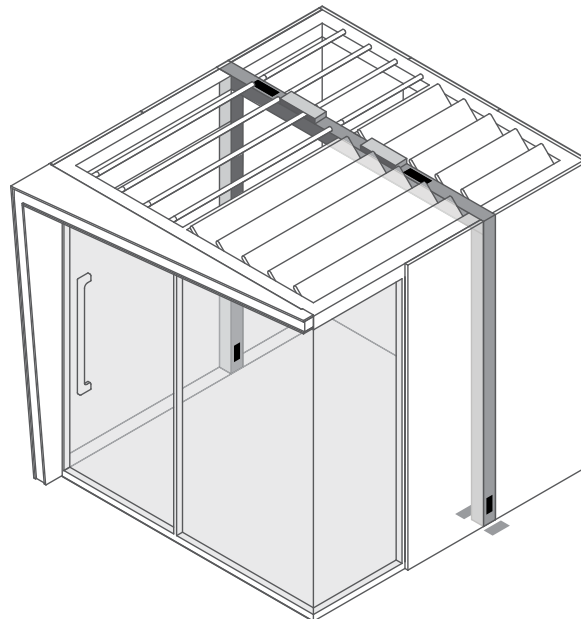

Recommended floor box position:

Near service hoop either on the outside or the inside of the camper.

Section 9

Seismic Kit

Seismic Kit

A Seismic Kit is available for installations in seismic regions.

Refer to the Seismic Engineering Report for any installation restrictions in certain seismic zones.

The Structural Engineer of Record (SEOR) must refer to the Seismic Engineering Report for anchorage recommendations.

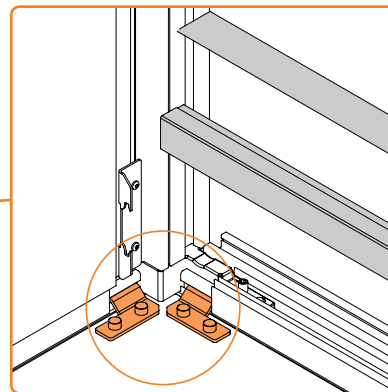
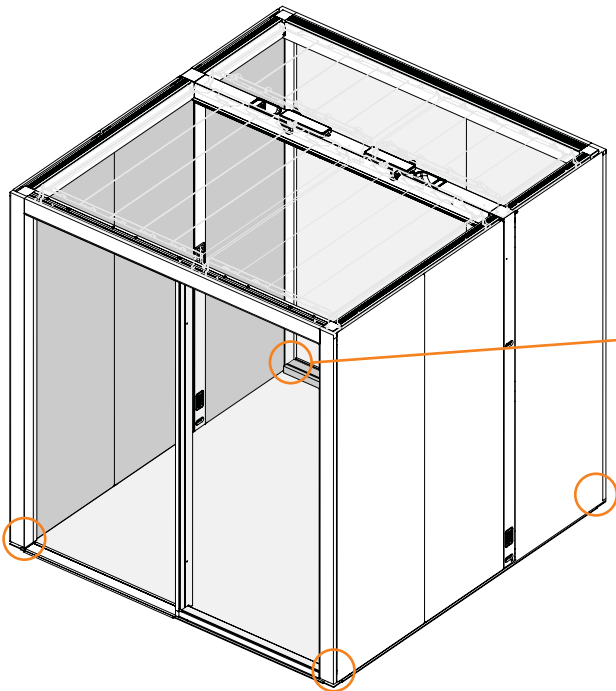
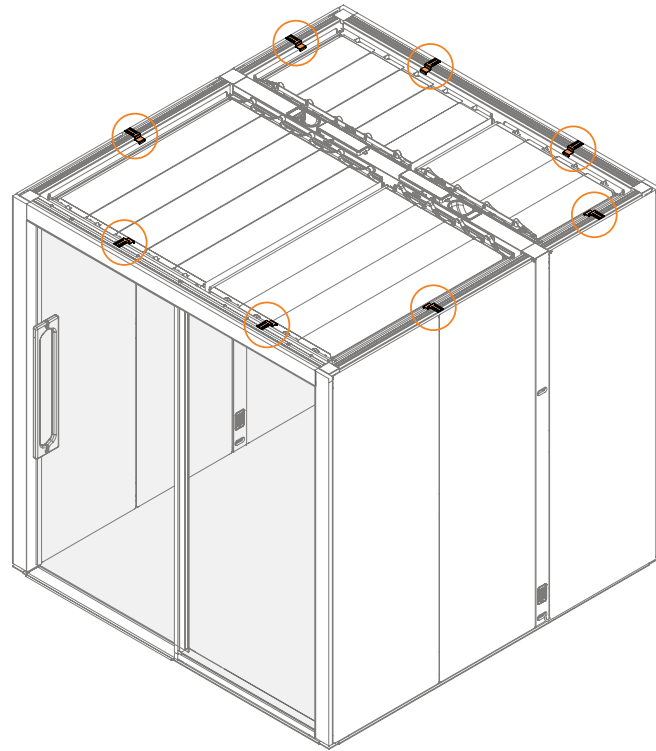

Section 10

ADA Compliance

ADA Compliance

Orangebox campers are designed with accessibility as a priority, with features providing compliance with ADA Standards for Accessible Design.

Door Opening

The door exceeds the 32" minimum opening and has a compliant door 'grab handle' designed with less than 5 lb of force required to open and close.

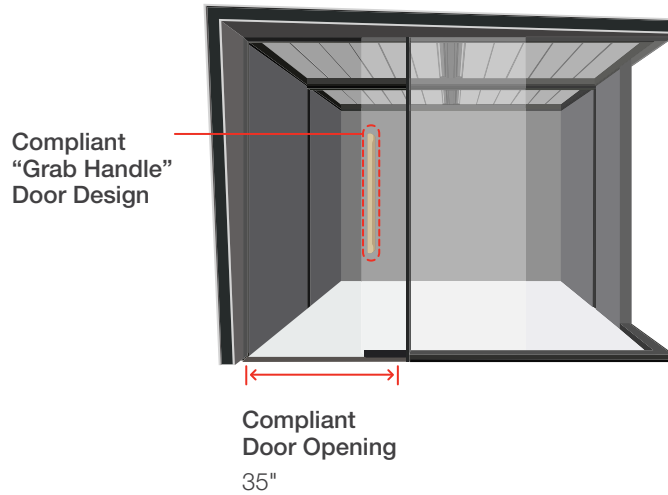

Threshold

Wheelchair access: the low profile track makes it easy for the wheels to roll over.

User Control Module

Buttons and sockets are mounted at compliant heights.

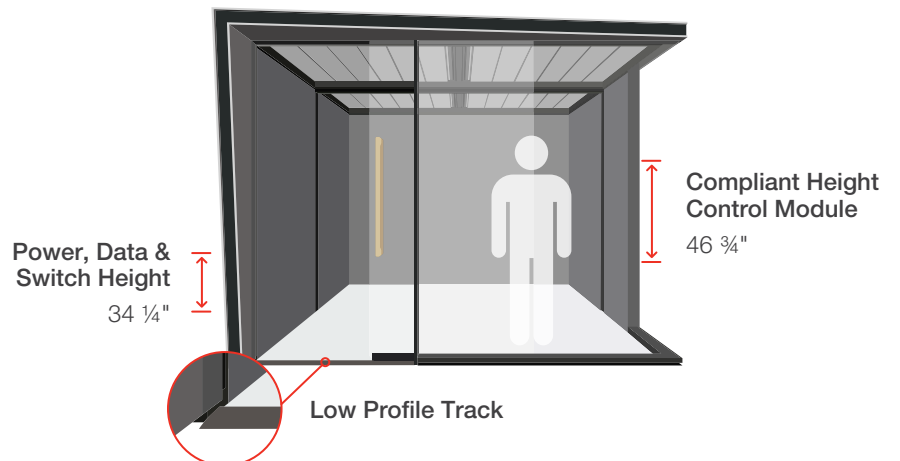

Wheelchair Turning Circle

CD02 Camper

88"W x 92"D

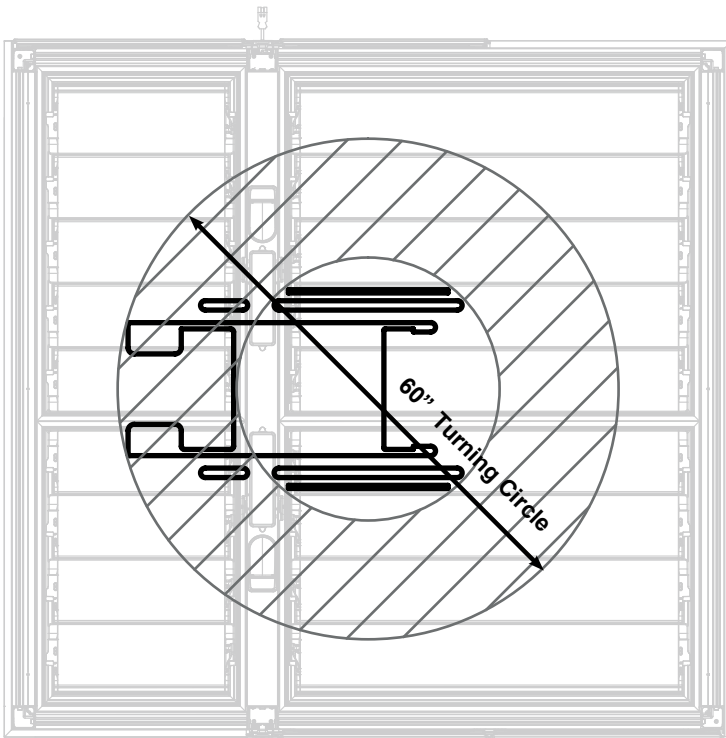
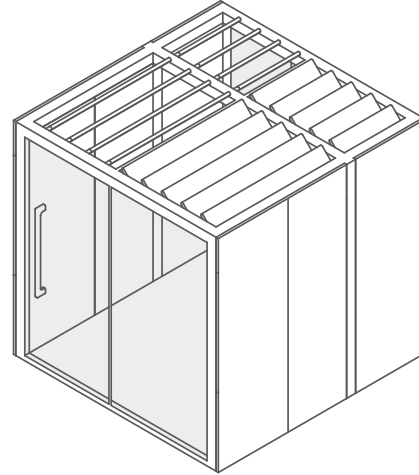

All Orangebox campers have features to provide compliance with ADA Standards for Accessible Design/ ICC A 117.1 Accessible and usable buildings & facilities.

Wheelchair Turning Circle

CD05 Camper

115"W x 119"D

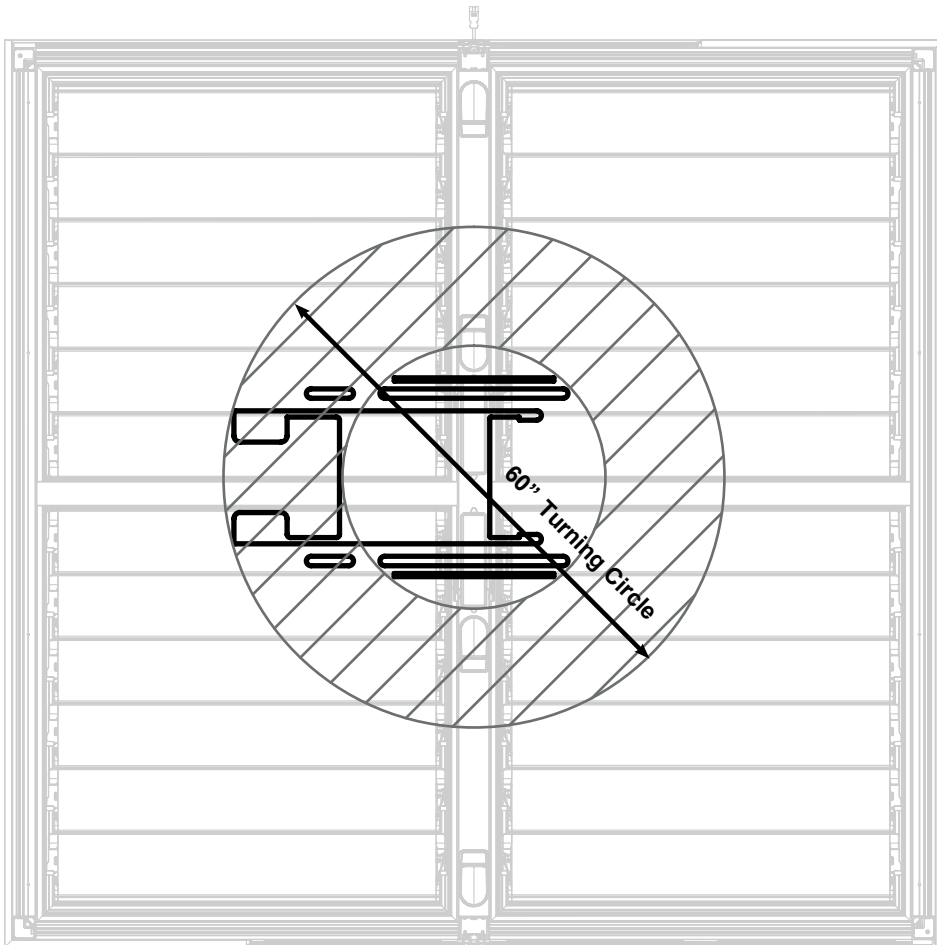
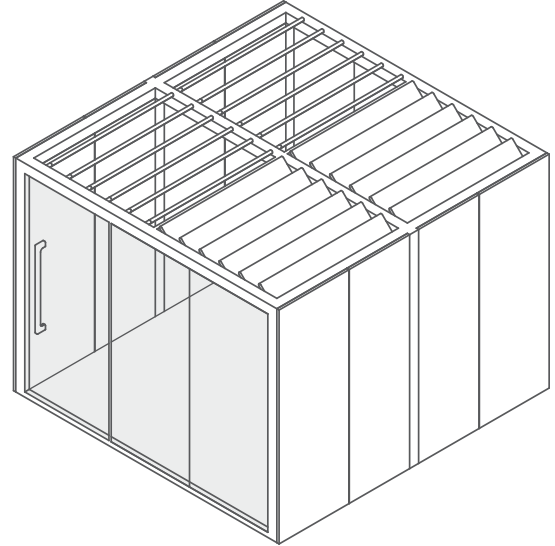

All Orangebox campers have features to provide compliance with ADA Standards for Accessible Design/ ICC A 117.1 Accessible and usable buildings & facilities.

Section 11

Standards/ Compliance

Product Related Compliance/Standards

Campers & Dens products have been designed, engineered, and manufactured, to meet or exceed all applicable ANSI/BIFMA (American National Standards for Office Furnishings) requirements for safety and performance.

Campers and Dens was tested to appropriate test methods in the following ANSI/BIFMA standards:

ANSI/BIFMA X5.6-2016 (R2021) – Panel Systems
ANSI/BIFMA X5.4-2020 Public and Lounge Seating

Campers & Dens is in compliance with the recommendations from BIFMA Pods-2020 Business & Institutional Furniture Industry Guidance for Pods, dated September 23, 2020:

Electrical Considerations

Campers & Dens campers are listed to UL 962

Ventilation Considerations

ANSI/ASHRAE Std. 111-2008

Fire Safety Considerations

ASTM E84, UL 723 and ULC S102-2010

Glass Considerations

International Building Code (IBC) Section 2403.4 Interior Glazed Areas, all safety glass is specified to meet industry and regulatory standards, ANSI Z97.1, CPSC 16CFR1201, and CAN/CGSB-12.1-M

Specialist Finishes:

See individual manufacturers data cards

- Fabrics, including Awning Fabric
- PET
- Poplar Plywood
- Cord
- Laminate Panels

Steelcase/Orangebox uses its own **ISO 9001 registered** and **ISO 17025 accredited** laboratories, and accredited independent laboratories, to verify compliance to the Standards and requirements listed. A list of accredited independent laboratories is available upon request.

Steelcase/Orangebox products are designed and tested for code and standard compliance when installed and used as an integrated product solution in accordance with Steelcase/ Orangebox application guidelines and assembly directions. The use of unauthorized non-Steelcase/ Orangebox components, parts, or materials with integrated Steelcase/ Orangebox product solutions VOIDS all Steelcase/ Orangebox claims of product compliance to BIFMA, UL, CSA, LEED, and / or any office furniture safety or performance standards, including all building, fire, and electrical codes. This exclusion includes but is not limited to the use of non-Steelcase/ Orangebox panel supported work surfaces, leg supports, panels, brackets, shelves, overhead bins, and other integral components. The use of non-Steelcase/ Orangebox components in an integrated product solution not designed, tested, or supported, by Steelcase/ Orangebox is an unauthorized modification of the original product which voids all Steelcase/ Orangebox warranties, expressed or implied.

Section 12

Warranty

Americas Warranty

Orangebox US Inc. warrants exclusively to the original Purchaser of our product that all products (based on 8 hours use per day) will be free from defects in workmanship and material for a period of ten (10) years from the date of manufacture. Subject to the exceptions listed below.

Orangebox US Inc will repair or replace with comparable product at its option. Orangebox US Inc warranties are also subject to the client carrying out regular monthly inspections and maintenance, and that any potential defects should prompt the client to remove the product from service and inform Orangebox Inc accordingly.

Exceptions

- Orangebox US Inc Campers & Dens Pods are provided with a 10 year structural warranty, and subject to the pods being installed and re configured using Orangebox certified installers only.
- Orangebox US Inc Campers & Dens pods electrical components are provided with a 2 year warranty, and subject to the pods being installed and reconfigured using Orangebox certified installers and our terms and conditions.
- Any Upholstery materials including COM, Fabrics, leathers and vinyl's and other surface coatings. These will be supported by the individual suppliers explicit warranty for that product.
- Products considered consumables such as LED lighting
- Products distributed outside of listed region

Failure to comply with the following elements will render any explicit or implied warranty offered by Orangebox US Inc null and void:

- The glass should only be installed and or reconfigured in accordance with Orangebox site assembly instructions and by Orangebox certified installers.
- Glass handling safety equipment should be used in accordance with Orangebox assembly instructions.
- Glass handling & installation should be in accordance with health and safety site specific requirements

This warranty applies to Orangebox products delivered into North America, Central America, South America and the Caribbean.

Exclusions

- Any damage caused during onward freight or improper storage of the product, or damage caused by accident, and normal wear and tear.
- Any abuse, misuse, or accident.
- Any products or components not installed or reconfigured using Orangebox US Inc certified installers.
- Color Variations – While every effort is made to ensure parity of color, the company cannot guarantee an exact color match on any painted metal finish or wood, or guarantee against commercial variance in fabrics, especially on repeat orders.
- Natural product changes – Changes due to aging or exposure to light, and naturally occurring markings, scarring and wrinkles in leather.
- Improper customer installation.
- Unapproved modifications to the products carried out by the customer or dealer.

THIS LIMITED WARRANTY IS THE SOLE REMEDY FOR PRODUCT DEFECTS AND NO OTHER EXPRESS OR IMPLIED WARRANTY IS PROVIDED, INCLUDING BUT NOT LIMITED TO ANY IMPLIED WARRANTIES OF MERCHANTABILITY OR FITNESS FOR A PARTICULAR PURPOSE. ORANGEBOX US INC SHALL NOT BE LIABLE FOR ANY CONSEQUENTIAL OR INCIDENTAL DAMAGES ARISING FROM ANY PRODUCT DEFECT.



orangebox

Contact

us.support@orangebox.com

SMR #23-000000100CM ©2024 Orangebox. All rights reserved.
All specifications subject to change without notice. Trademarks used herein are
the property of Orangebox or their respective owners.

steelcase.com/brands/orangebox