

MODELS AIR-23, AIR-25, AIR-27, AIR-29

⚠ CAUTION



CRUSH HAZARD!

FAILURE TO PROPERLY SECURE PRODUCT TO BUILDING COULD RESULT IN PERSONAL INJURY.

For commercial use only. Read all instructions before using the Air3 pod. Save these instructions for future reference.

DANGER – To reduce the risk of electric shock, always unplug this furnishing from the electrical outlet before cleaning or servicing.

WARNING – To reduce the risk of burns, fire, electric shock, or injury to persons:

- Unplug from the outlet(s) before putting on or taking of parts.
- Use this furnishing only for its intend use as described in these instructions. Do not use attachments not recommended by the manufacturer
- Never operate this furnishing if it has a damaged cord or plug, or if it is not working properly. Contact the dealer for examination and repair.
- Keep Cords away from heated surfaces
- Do not operate where aerosol (spray) products are being used or where oxygen is being administered.
- To disconnect from power, turn all controls to the off position, then remove plug(s) from outlet
- Mount only approved work surfaces and secondary surfaces (Shelves) in accordance with instructions. Failure to do so may cause instability , collapse, or failure of electrical components



POD INSTALLATION DOCUMENT

Contents page

1) Supporting documents	1.1
<i>PPE Information</i>	1.5
<i>Pod range overview</i>	1.6 – 1.10
2) Service hoop assembly	2.1
<i>Setting out floor jigs</i>	2.2 – 2.6
	Sign off position of pod
<i>Setting out hoop</i>	2.8
<i>Opening hoop covers</i>	2.9
<i>Connecting cables in switch side hoop vertical</i>	2.11
<i>Attaching the actuators</i>	2.12
<i>Separating fan from the main body</i>	2.15
<i>Securing main fan body to hoop</i>	2.16
<i>Installing fan to main body</i>	2.17
<i>Americas heat detector mounting</i>	2.18.2 – 2.18.3
<i>Connecting cables in switch side hoop vertical</i>	2.18.1 / 2.18.3
<i>Connecting cables in power side hoop vertical</i>	2.19
<i>Electrical Schematic layouts/ electrical connection</i>reference.....	2.24 – 2.28
<i>Connecting hoop vertical to hoop horizontal</i>	2.29
<i>Standing hoop up</i>	2.30
3) Main screens assembly	3.1
<i>Hooking screens into hoop and checking hook positions</i>	3.2
<i>Order of attaching screens to hoop</i>	3.3
<i>Attaching hoop brackets and checking alignments</i>	3.4
<i>Attaching top screen covers to check alignments</i>	3.5
<i>Attaching fan cowls and plugging fan in</i>	3.6
4) Front and back glass frame assemblies	4.1
<i>Square frame assembly option 1</i>	4.2
<i>General assembly of the frame</i>	4.3
<i>Front frame assembly</i>	4.4 – 4.4.1
<i>Back frame assembly</i>	4.5 – 4.5.1
<i>Attaching the assembled frames to the pod</i>	4.6 – 4.6.1
<i>Square frame assembly option 2</i>	4.7
<i>Location of bottom door tracks</i>	4.8
<i>Locating uprights onto bottom door track</i>	4.9
<i>Attaching uprights onto main screens</i>	4.10
<i>Locating top crossbar</i>	4.11
<i>Connect the rear glass frame</i>	4.12
5) Opening and fixed roof assemblies	5.1
Opening roofs - Aluminium	5.8
<i>Aluminium roof</i>	5.9 - 5.18
<i>Aluminium roof panel configurations with part numbers</i>	5.19 - 5.25
Opening roofs - Assembly Sequence	5.27
<i>Adding actuator cowl covers</i>	5.28
<i>Positioning the opening roof panels</i>	5.29

Profile views of installed roof panels (opening).....	5.30
Attaching crank arm to main actuator body.....	5.31
Checking that roof blades are completely closed.....	5.32
Adjustment of actuators to aid in closing roof blades.....	5.33
Securing crank arms to main body and replacing cowls.....	5.34– 5.35
	Sign off position of pod
6) Upholstery panels assembly	6.1
Fabric panel tolerances.....	6.2
Attaching external upholstery panels.....	6.3
Removing anti slip bung mouldings.....	6.4
Adding bottom corner mouldings.....	6.5
Positions of clips on external square pod panels.....	6.6
Fastening external upholstery panels with fixings.....	6.7
Attaching internal upholstery panels.....	6.8
Positions of clips on external square pod panels.....	6.9
7) Front and back glass	7.1
Position of glass panels within different pod models.....	7.1.1 – 7.1.4
Rear Glass	7.2
Bonding the joining strip to the glass.....	7.3
Loading the glass into the frame.....	7.4
Levelling the glass.....	7.5
Preparing the joining strips.....	7.6
Joining the glass.....	7.7
Sealing the glass.....	7.8
Securing the glass with metal clamping brackets.....	7.9
Front glass	7.10
Bonding the joining strip to the glass.....	7.11
Loading the glass into the frame.....	7.12
Packing the top crossbar against the glass.....	7.13
Levelling the glass.....	7.14
Preparing the joining strips.....	7.15
Joining the glass.....	7.16
Sealing the glass.....	7.17 – 7.18
8) Glass door Installation	8.1
Assembling door runners.....	8.2
Bottom door track glides into glass.....	8.3
Lifting door onto track.....	8.4
Levelling door.....	8.5 – 8.7
Door handle assembly.....	8.8
Back door edge seal.....	8.9
Top corner finishing caps.....	8.10
Door stop.....	8.11
Door track cover clips.....	8.12
Door track / rear covers.....	8.13
	Sign off position of pod
9) Accessories	9.1
Screen mounted whiteboards.....	9.2 – 9.5
Screen mounted fixed monitor brackets.....	9.6 – 9.10
Hoop mounted fixed bracket.....	9.17 – 9.22
Hoop mounted tables.....	9.23 – 9.29
ADA door expansion/NIB.....	9.37
10) The knack	10.1 (10.1 - 10.17)
The knack contents page.....	10.1.1

Supporting documents



⚠ WARNING

* NO UNAUTHORISED PERSONNEL PERMITTED TO PARTICIPATE IN ASSEMBLY (ORANGEBOX CERTIFIED PERSONNEL ONLY)

* APPROPRIATE PPE MUST BE WORN AT ALL TIMES DURING ASSEMBLY OF ORANGEBOX PRODUCTS

* PART ASSEMBLED PODS MAY NOT BE LEFT UNATTENDED UNLESS STRUCTURALLY SOUND

TOOLS / EQUIPMENT REQUIRED FOR INSTALL

Glass Items

Quantity	Description
2	Vacuum Suction Cups - 8" or 9" (With Low Vacuum Audio Alarm)
1	Safety Glasses (1 pair per installer)
1	Safety Gloves (1 Pair per installer)
2	Plastic Gasket Roller (Tool to seal glass) - Sold Separately
1	Alignment Jig - Sold Separately
Pack	Isopropanol (IPA) Wipes

Tools/Equipment

Quantity	Description
1	Cordless Drill (for use on external fabric panels only. Do not use on aluminum.)
1	Phillips #3 Driving Bit (for drill)
2	6ft Folding Ladder
1	White Mallet
1	Glass Cleaner
2	Glazing Shovel (Plastic Hoop Opener) - Sold Separately
1	Straight Cut Aviation Snips (or similar)
1	Metric T-Handle Hex Key - 2.0mm
1	Metric T-Handle Hex Key - 2.5mm
1	Metric T-Handle Hex Key - 3.0mm
1	Metric T-Handle Hex Key - 4.0mm
1	Metric T-Handle Hex Key - 5.0mm
1	Metric T-Handle Hex Key - 6.0mm
1	13mm 12-Point Metric Combination Wrench
1	Torque Wrench (Must Reach 14NM/10.32 ft)
1	5mm Hex Bit Socket (For Torque Wrench)
1	6mm Hex Bit Socket (For Torque Wrench)
1	Retractable Utility Knife
1	12" Medium Trigger Clamp
1	16' Tape Measure
1	8" Linesman Pliers (or similar)(used for knockdown of Pod)

Tools/Equipment

1	12" Wonder Nar Pry Bar (or similar)
1	NM Gauge
1	Hoop Leaver
1	T-Handle Flat
1	Screw Driver
1	Small Driver
1	Small Crossbar
1	Roller
1	Spirit Level
1	Trigger Clamps
1	12mm VHB TPE / Electrical Tape
Pack	Isoproponal (IPA) Wipes
1	No 13 Wrench
1	Amored Corner Protectors
8	Floor Slide Guides
1	10mm Wrench
1	Steamer
1	Circuit Tester Pen + Plug Socket Tester

Alignment Jigs

Jigs	Pods	Page
Half Square Pod Alignment Jig	Air - 23	2.8
Square Pod Alignment Jig	Air - 25	2.9
Rectangle Pod Alignment Jig	Air - 27	2.10
3 x 3 Square Pod Alignment Jig	Air - 29	2.11

PPE LEVELS REQUIRED FOR INSTALLATION



**LEVEL 1
STANDARD ORANGETBOX
INSTALL UNIFORM**
- SHIRT
- TROUSERS
- SAFETY SHOES



**LEVEL 2
BASIC REQUIRED PPE**
-GOGGLES
-GLOVES
-KEVLAR WRIST
/ ARM PROTECTORS



**LEVEL 3
ADDITIONAL EXTRA PPE**
-HARD HAT
-HIGH VISABILITY JACKET
-EAR PLUGS

⚠ WARNING



Assembly Directions at
ussupport.orangebox.com





Risk of Fire, Injury or Electrical Shock.

- The roof surface is not load bearing. Do not put any objects on the roof surface.
- When installed in accordance with Assembly Directions may be used beneath sprinklers subject to Authorities Having Jurisdiction.
- Only use in locations with standard response sprinklers.
- Do not block or obstruct fan vents and grills.
- Do not drill holes in or attempt to hang items on product.
- Relocation of product to be performed only by professional installers trained and certified by Orangebox. DO NOT push the product to move.
- Read instructions before opening covers/making electrical connection.
- Isolate mains power before removing access panels & disconnecting electrical components.
- This device must be grounded.

Line Voltage - Black
Neutral - White
Ground - Green

⚠ AVERTISSEMENT

Risque d'incendie, de blessure ou de choc électrique.

- La surface du toit ne peut supporter de poids. Ne placez aucun objet sur le toit.
- Lorsqu'ils sont installés conformément aux Instructions de l'Assemblée peuvent être utilisés sous les gicleurs sous réserve des Autorités Compétentes.
- N'utilisez que dans les endroits avec des gicleurs d'intervention standard.
- Ne bloquez pas ou n'obstruez pas les sorties des ventilateurs ni les grilles.
- Ne percez pas de trous dans la paroi et ne suspendez aucun objet à la produit.
- Le produit doit uniquement être déplacée par des installateurs professionnels, formés et certifiés par Orangebox. ÉVITEZ de pousser sur la produit pour la déplacer.
- Lisez les directives avant d'ouvrir les couvercles ou de faire les branchements.
- Isolez l'alimentation secteur avant de retirer les panneaux d'accès et de déconnecter les composants électriques.
- Cet appareil doit être mis à la terre.

Tension de Ligne - Noir
Neutre - Blanc
Mise à la Terre - Vert

⚠ ADVERTENCIA

Riesgo de incendio, lesiones o descarga eléctrica.

- La superficie del techo no soporta carga. No coloque ningún objeto sobre la superficie del techo.
- Cuando se instala de acuerdo con las Instrucciones de Montaje, se puede usar debajo de rociadores sujetos a las Autoridades Competentes.
- Solo úselo en lugares con rociadores de respuesta estándar.
- No bloquee ni obstruya las rejillas y conductos de ventilación de los ventiladores.
- No taladre orificios ni intente colgar artículos en la producto.
- Se debe realizar la reubicación del producto únicamente por instaladores profesionales capacitados y certificados por Orangebox. NO empuje la producto para moverla.
- Lea las instrucciones antes de abrir las tapas / hacer la conexión eléctrica.
- Aísle la energía de la red antes de quitar los paneles de acceso y desconectar los componentes eléctricos.
- Este dispositivo debe estar conectado a tierra.

Tensión de línea - Negro
Neutro - Blanco
Tierra - Verde

PN 1460111001, Doc # 158174, rev G



LISTED
E332997

For Commercial Use Only
Solo Para Uso Comercial
À Usage Commercial Uniquement
Conforms to UL Std 962
Certified to CSA C22.2 #68

AIR-23 OPENING ROOF HALF SQUARE POD

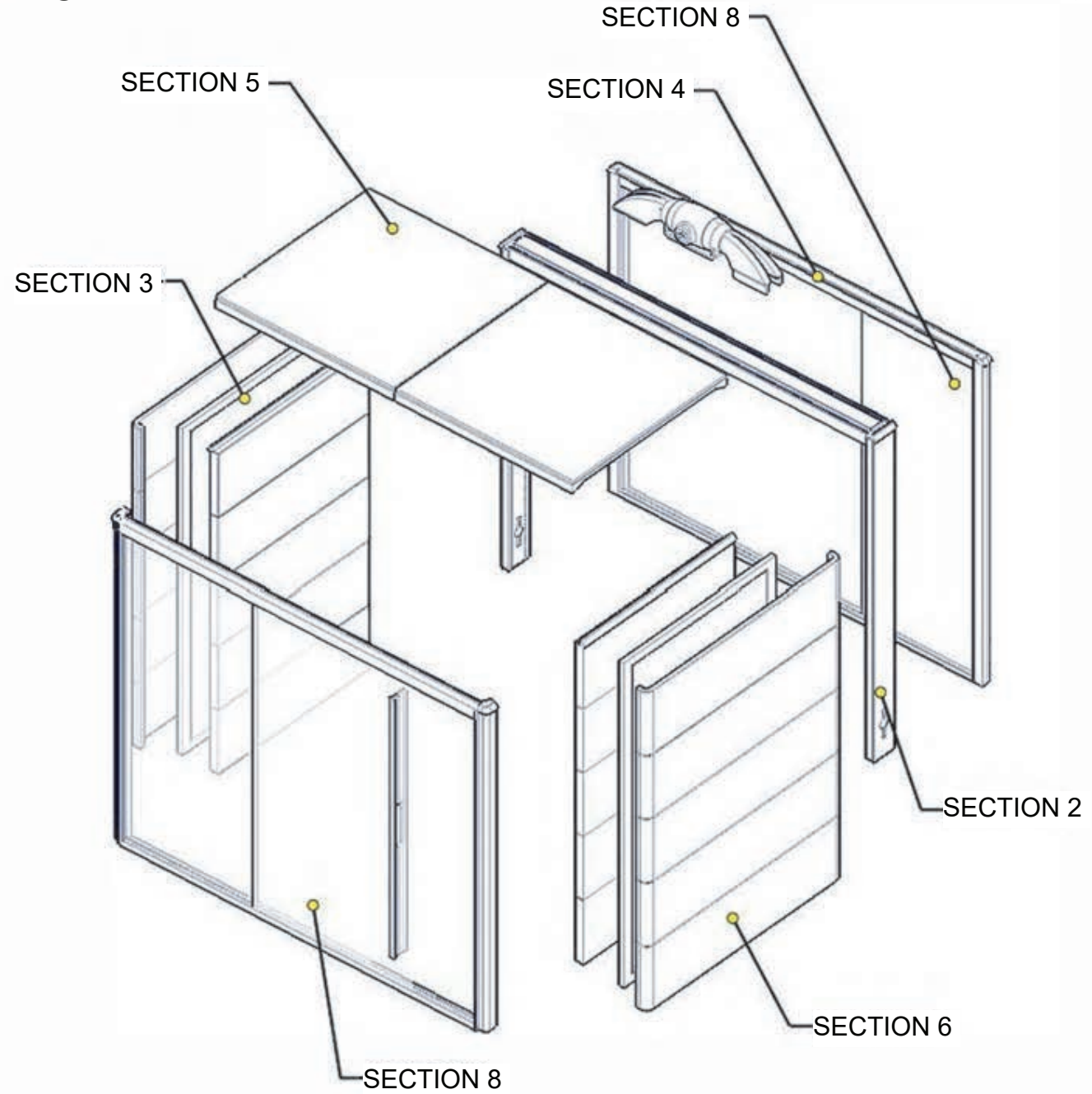
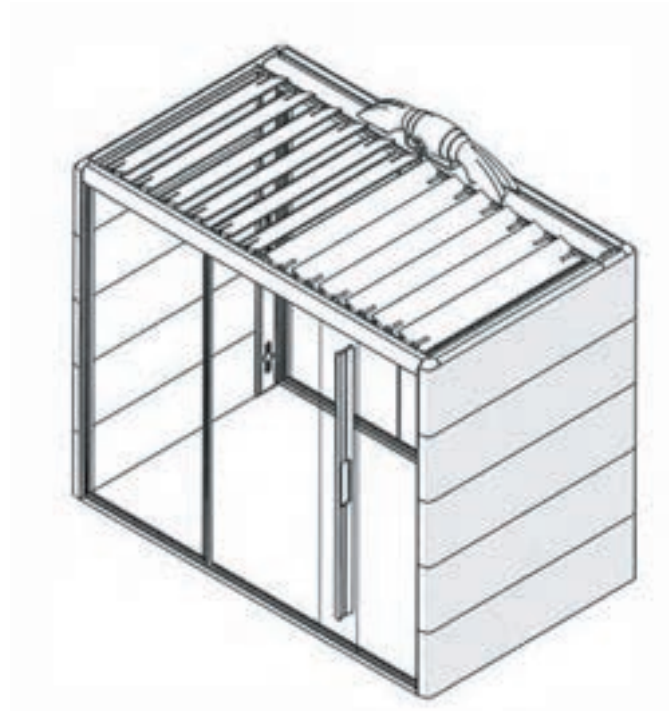

***NOTE SECTION NUMBERS RELATE TO SECTIONS FOUND IN THIS DOCUMENT. SEE CONTENTS PAGE

AIR-25 OPENING ROOF SQUARE POD

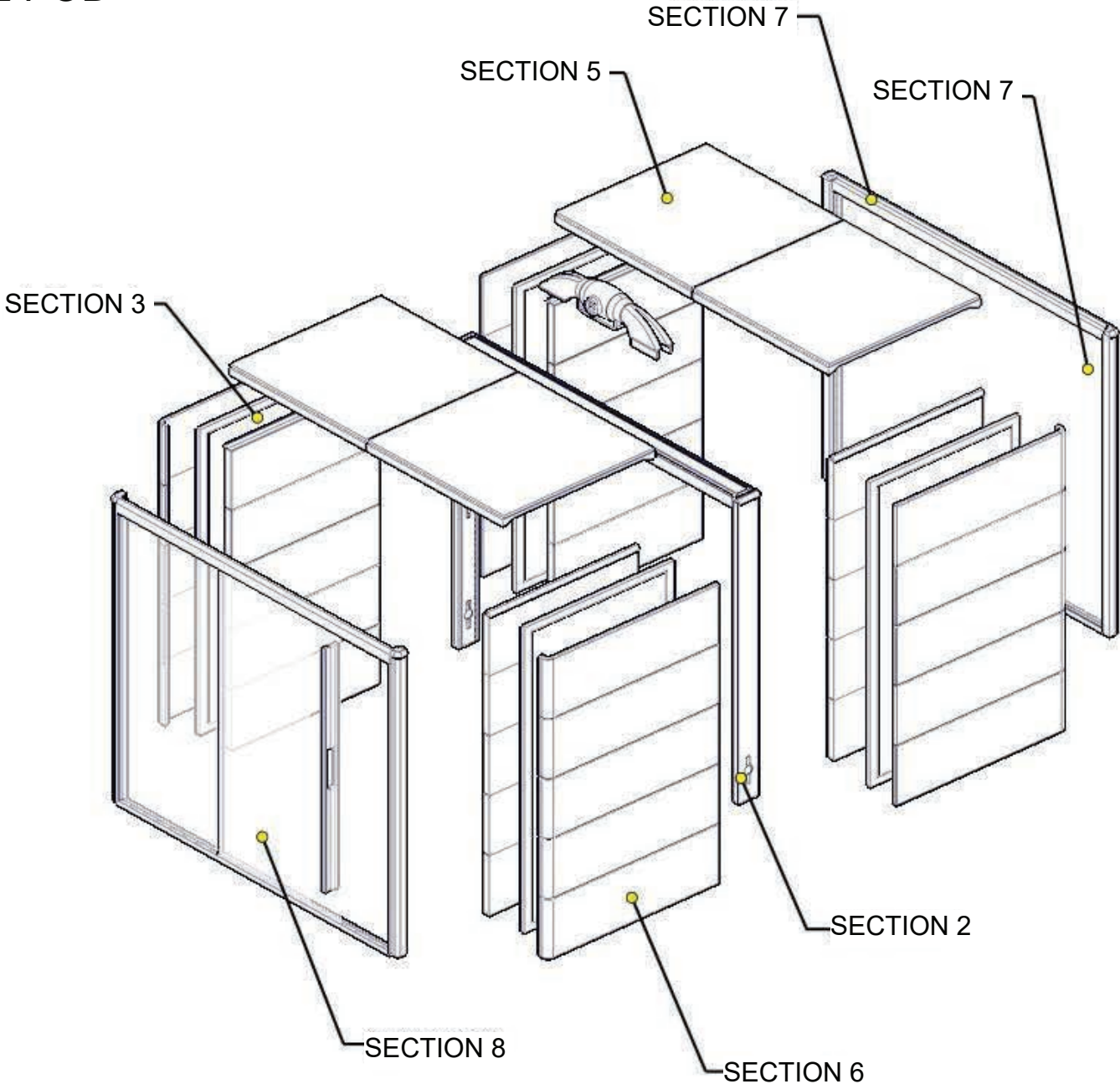

***NOTE SECTION NUMBERS RELATE TO SECTIONS FOUND IN THIS DOCUMENT. SEE CONTENTS PAGE

AIR-27 OPENING ROOF RECTANGULAR POD

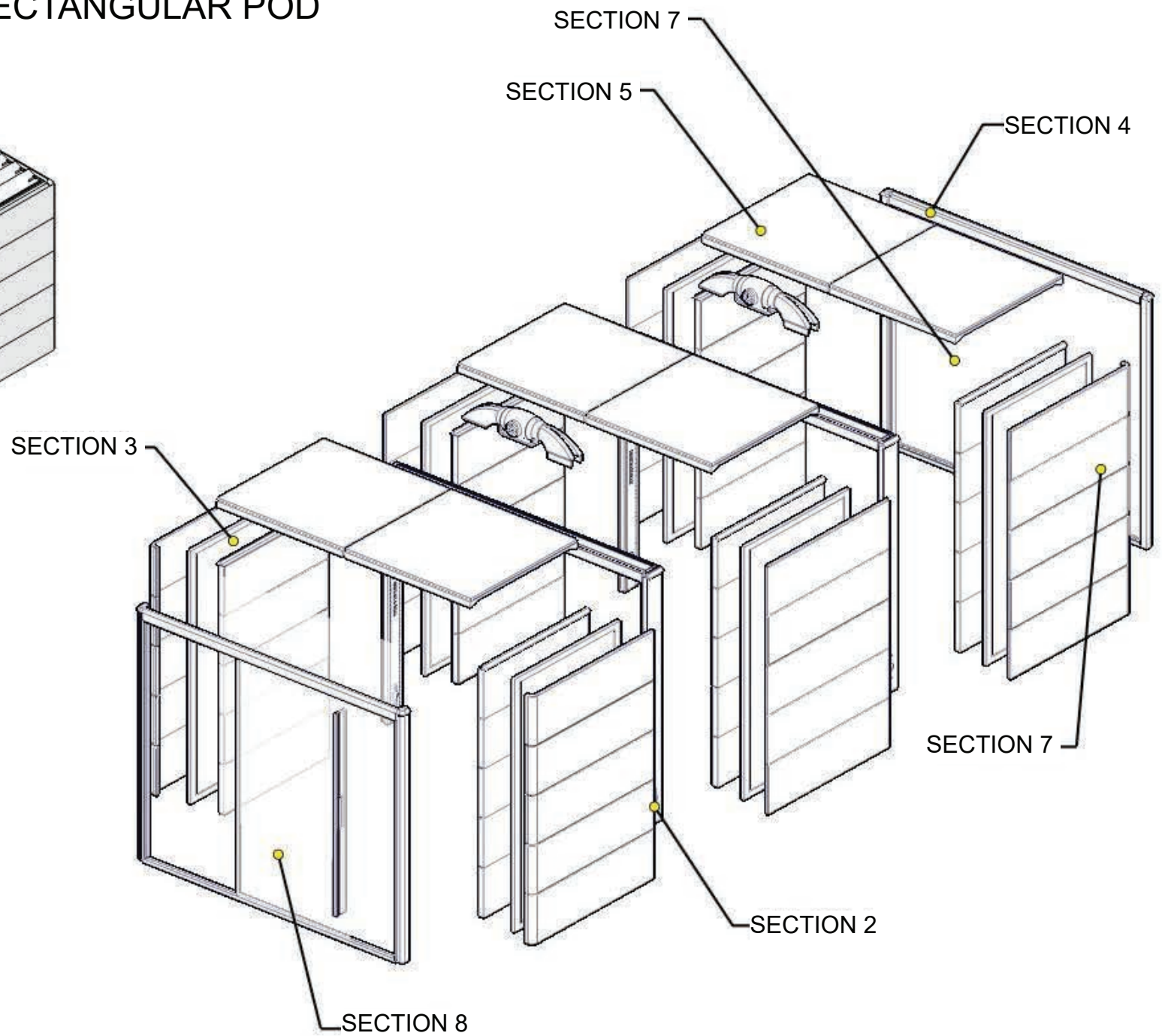
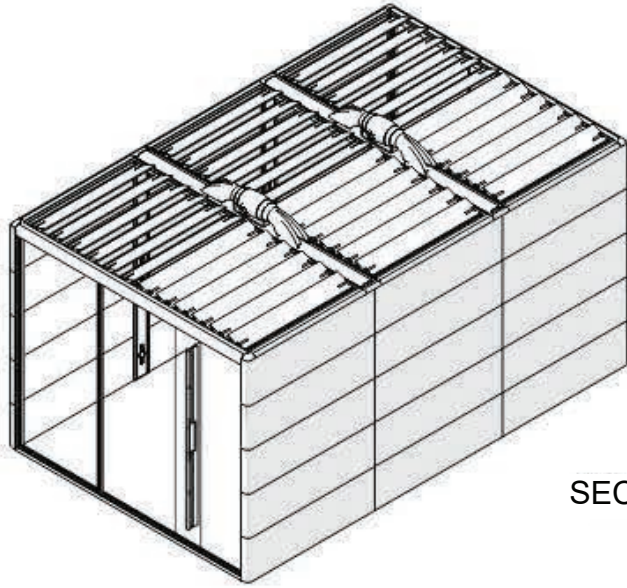

***NOTE SECTION NUMBERS RELATE TO SECTIONS FOUND IN THIS DOCUMENT. SEE CONTENTS PAGE

AIR-29 OPENING ROOF 3X3 SQUARE POD

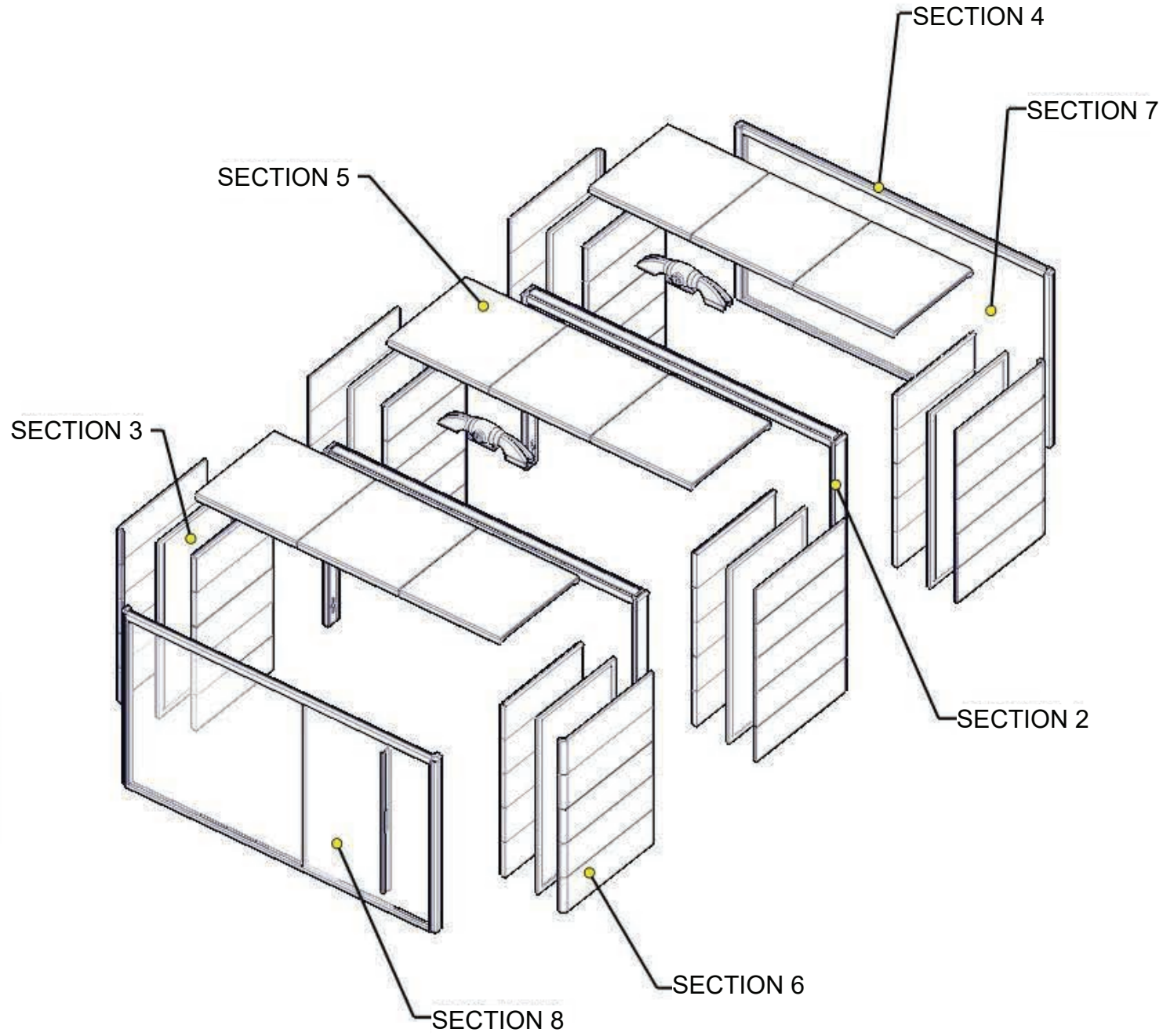
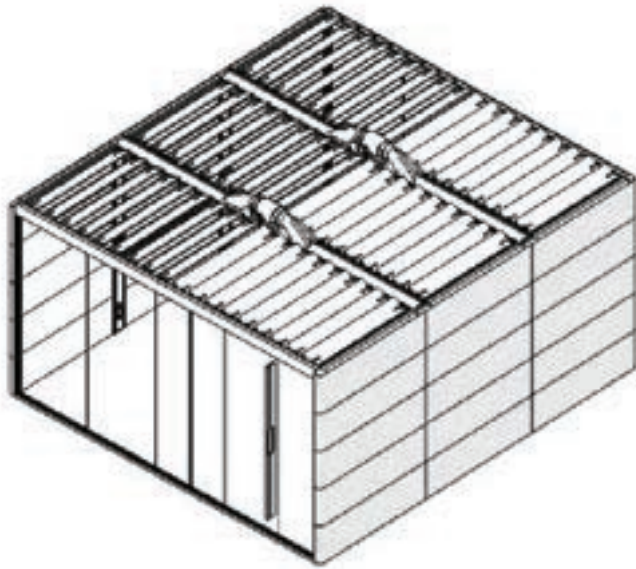

***NOTE SECTION NUMBERS RELATE TO SECTIONS FOUND IN THIS DOCUMENT. SEE CONTENTS PAGE

Assembly sequence

Service hoop assembly

section

2

* NO UNAUTHORISED PERSONNEL PERMITTED TO PARTICIPATE IN ASSEMBLY (ORANGEBOX CERTIFIED PERSONNEL ONLY)

* APPROPRIATE PPE MUST BE WORN AT ALL TIMES DURING ASSEMBLY OF ORANGEBOX PRODUCTS

* PART ASSEMBLED PODS MAY NOT BE LEFT UNATTENDED UNLESS STRUCTURALLY SOUND

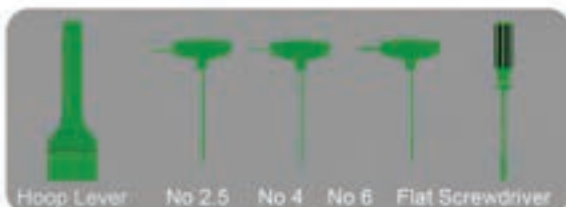

1 ASSEMBLE THE JIGS AS REQUIRED USING THE LAYOUT SHEETS PROVIDED*
*note jig is sold separately to Pod

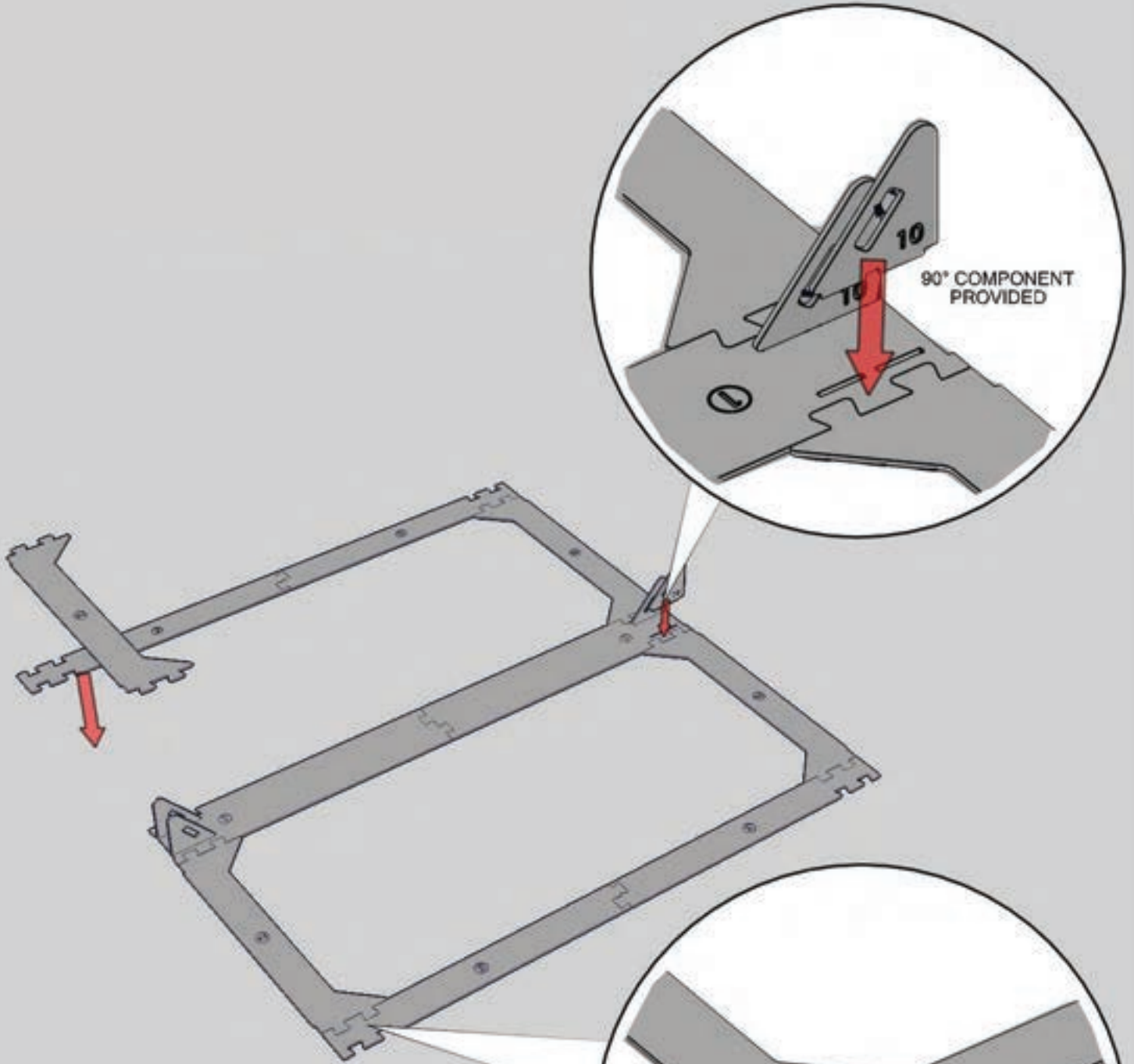

- LAY OUT JIGS TO SET POSITION OF POD
- ENSURE AREA IS FLAT AND FREE OF DEBRIS
- ENSURE THAT THERE IS ADEQUATE HEIGHT FOR POD
- USE AS SIGN OFF POSITION FROM CLIENT
- USE TO CHECK FLOOR BOX POSITIONS

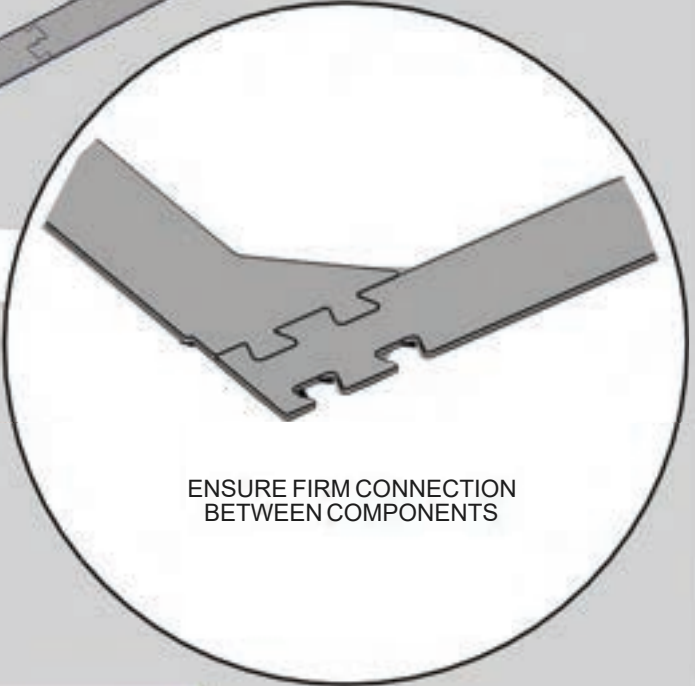

FINALLY, USE THE AIR-JIG-008
HOOP SET SQUARE PARTS TO
CHECK THE VERTICAL ANGLE OF THE
HOOP UPRIGHTS

4 4x

OPEN AND CORRECTLY POSITION
THE HOOP ALIGNMENT JIG
PARTS FIRST (NUMBERED 1)

1 2x

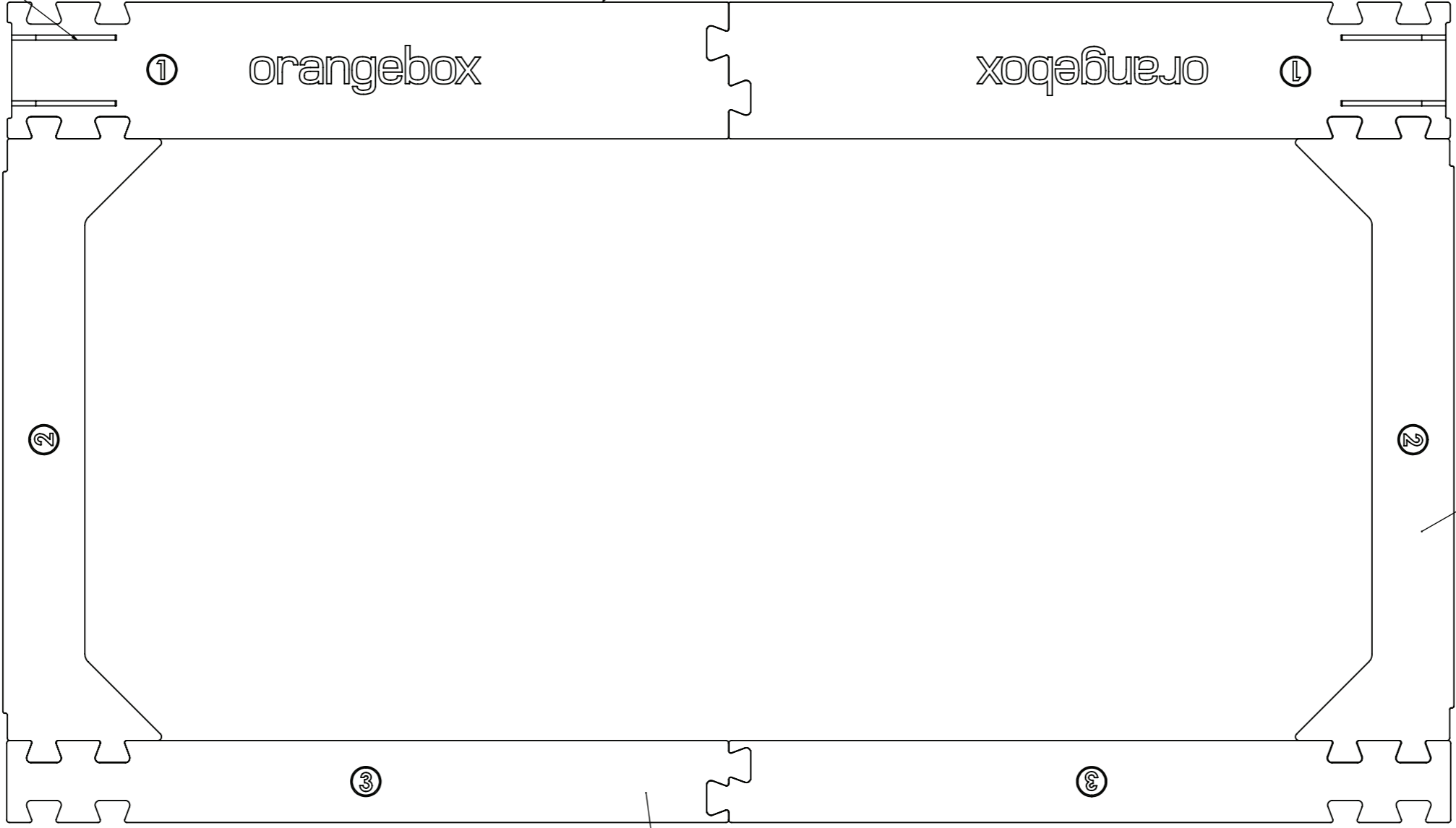

BUILD THE STRAIGHT
CONNECTOR PARTS
(NUMBERED 2) AROUND
THE CENTRAL HOOP
ALIGNMENT JIG

2 2x

COMPLETE THE OVERALL JIG
BY CONNECTING THE FRONT
ALIGNMENT PARTS (NUMBERED 3)

3 2x

KIT CONTENTS:
2 X AIR-JIG-001
2 X AIR-JIG-002
2X AIR-JIG-003
2 X AIR-JIG-008

FINALLY, USE THE AIR-JIG-008 HOOP SET SQUARE PARTS TO CHECK THE VERTICAL ANGLE OF THE HOOP UPRIGHTS

OPEN AND CORRECTLY POSITION THE HOOP ALIGNMENT JIG PARTS FIRST (NUMBERED 1).

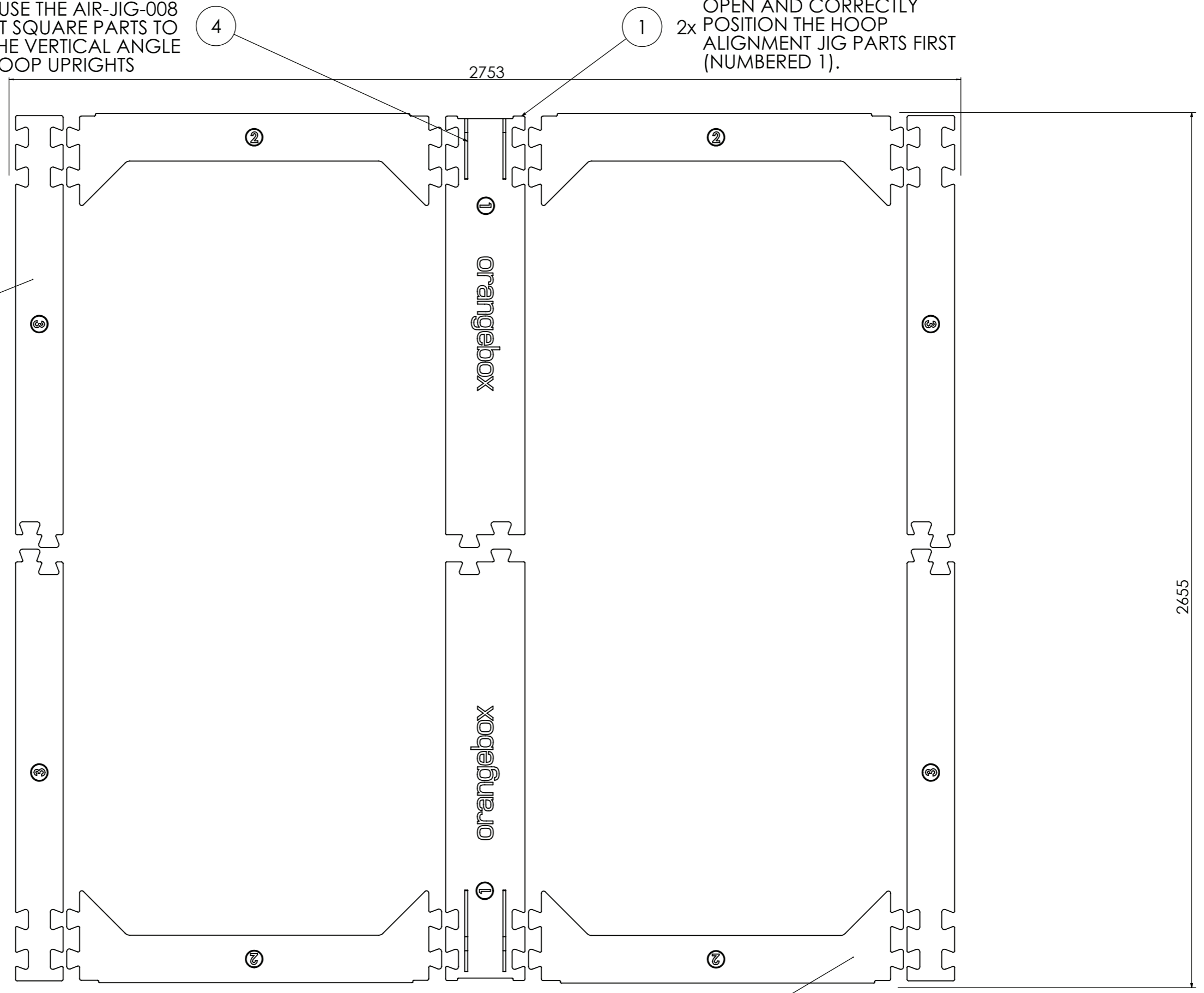

COMPLETE THE OVERALL JIG BY CONNECTING THE FRONT/ REAR ALIGNMENT PARTS (NUMBERED 3).

KIT CONTENTS:
2 X AIR-JIG-001
4 X AIR-JIG-002
4 X AIR-JIG-003
2 X AIR-JIG-008

BUILD THE STRAIGHT CONNECTOR PARTS (NUMBERED 2) AROUND THE CENTRAL HOOP ALIGNMENT PART JIG

FINALLY, USE THE AIR-JIG-008 HOOP SET SQUARE PART TO CHECK THE VERTICAL ANGLE OF THE HOOP UPRIGHTS.

OPEN AND CORRECTLY POSITION THE HOOP ALIGNMENT JIG PARTS FIRST (NUMBERED 1).

CONNECT THE TWO HOOP JIGS TOGETHER BY USING THE INTERMEDIATE CONNECTORS (NUMBERED 9).

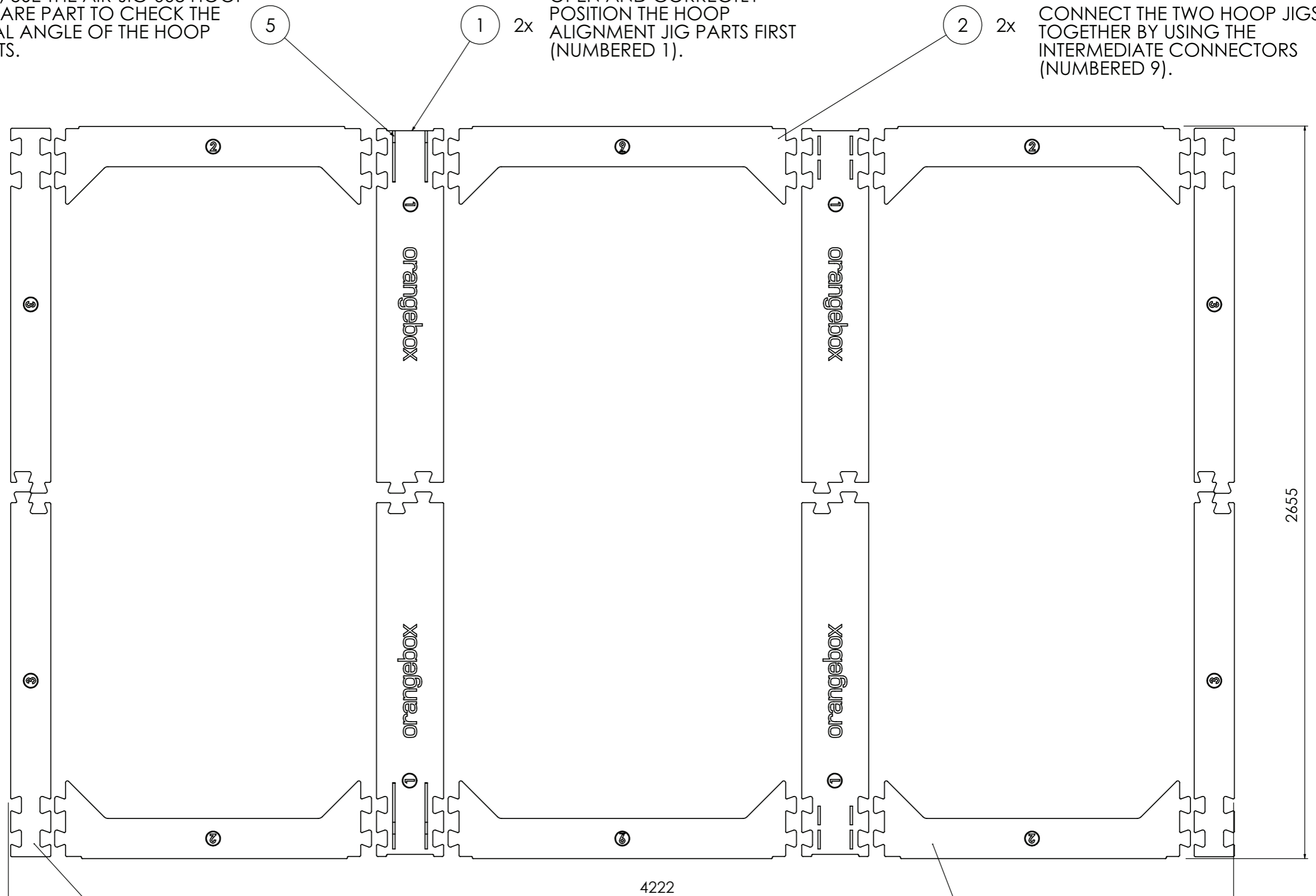

KIT CONTENTS:
4 X AIR-JIG-001
2 X AIR-JIG-007
4 X AIR-JIG-002
4 X AIR-JIG-003
4 X AIR-JIG-008

CONNECT THE STRAIGHT FRONT/
REAR ALIGNMENT JIGS (NUMBERED 3 & 4).

BUILD THE STRAIGHT CONNECTOR
PARTS AROUND THE TWO HOOP JIGS
(NUMBERED 2).

FINALLY, USE THE HOOP SET SQUARE PART TO CHECK THE VERTICAL ANGLE OF THE HOOP UPRIGHTS (NUMBERED 10).

5
1
6x

OPEN AND CORRECTLY POSITION THE HOOP ALIGNMENT JIG PARTS FIRST (NUMBERED 1 & 11).

2
2x

CONNECT THE TWO HOOP JIGS TOGETHER BY USING THE INTERMEDIATE CONNECTOR PARTS (NUMBERED 9).

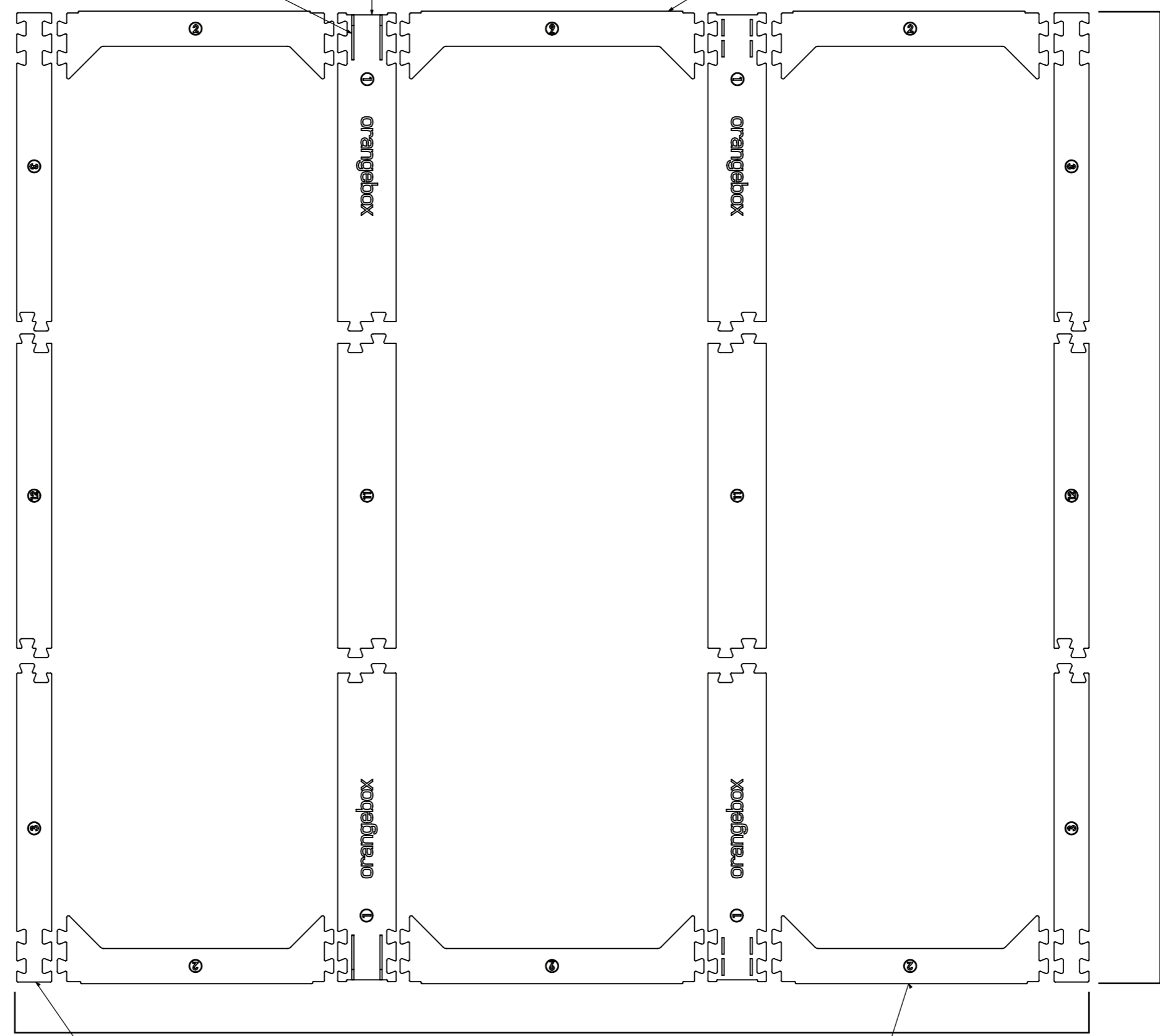

3945

4222

4
4x
CONNECT THE STRAIGHT FRONT/ REAR ALIGNMENT JIGS (NUMBERED 3 & 12).

3
4x
BUILD THE STRAIGHT CONNECTOR PARTS AROUND THE TWO HOOP JIGS (NUMBERED 2).

- KIT CONTENTS:
- 4 X AIR-JIG-001
 - 2 X AIR-JIG-009
 - 2 X AIR-JIG-007
 - 4 X AIR-JIG-002
 - 4 X AIR-JIG-003
 - 2 X AIR-JIG-010
 - 4 X AIR-JIG-008

LAY OUT HOOP ON FLOOR AS SHOWN

TO ENABLE EASY ACCESS TO HORIZONTAL COVER FOR CABLE ACCESS

PLAN VIEW

POWER SIDE

SWITCH SIDE

PIR & FUSE TO SWITCH SIDE

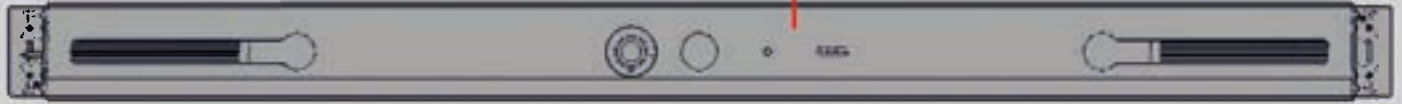

UPRIGHT (A)



UPRIGHT (B)

DO NOT DROP!
SENSITIVE & FRAGILE ELECTRICAL
EQUIPMENT INTEGRATED



CHECK
MINIMUM
CEILING
HEIGHT
FOR PODS
=2550MM
(100")

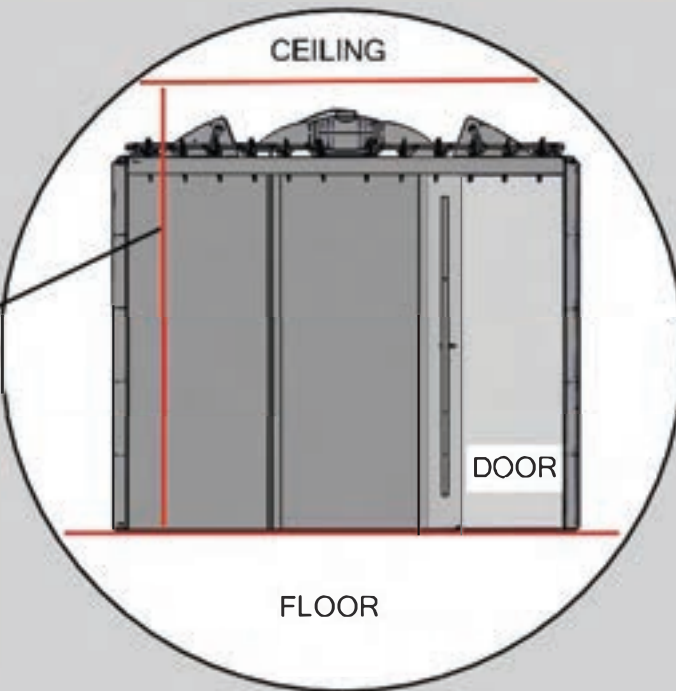

NOTE THAT THE SWITCH SIDE (UPRIGHT B) MUST ALWAYS
BE NEAREST THE DOOR TO ADJUST LIGHTS AS YOU ENTER POD

POWER SIDE

SWITCH SIDE



FACING FRONT
OF POD



ONE PERSON MINIMUM

1



2



USE THE PLASTIC TOOL TO OPEN THE HOOP COVERS.
DO NOT USE ANYTHING METAL TO DO THIS. IT WILL SCRATCH THE PAINTWORK.
OPEN ALL THREE COVERS AT THIS STAGE

OPEN THE HORIZONTAL HOOP COVER AND PUSH THE CABLE THROUGH THE CASTINGS AND INTO THE TWO VERTICAL UPRIGHTS

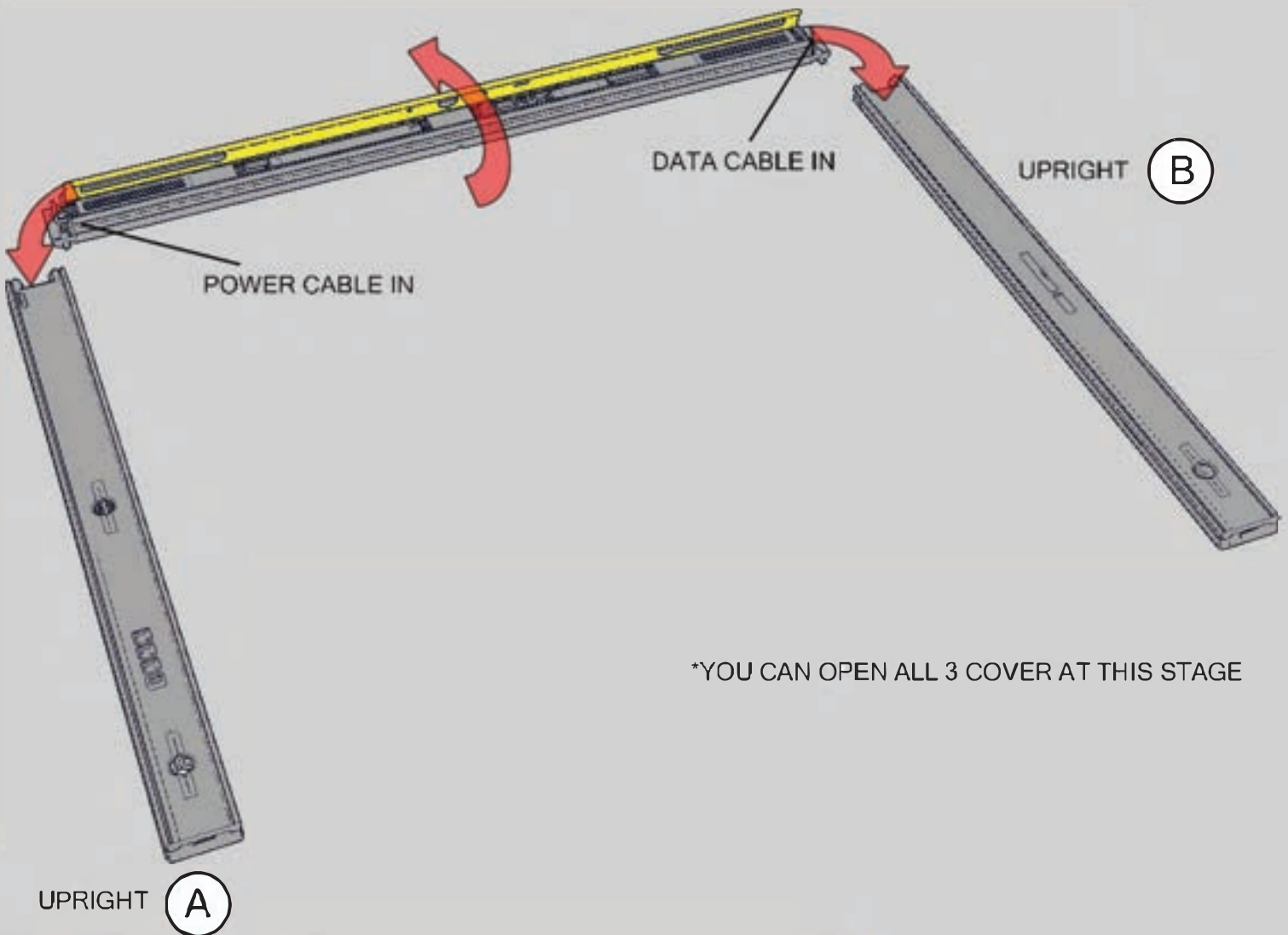

*YOU CAN OPEN ALL 3 COVER AT THIS STAGE



ONE PERSON MINIMUM

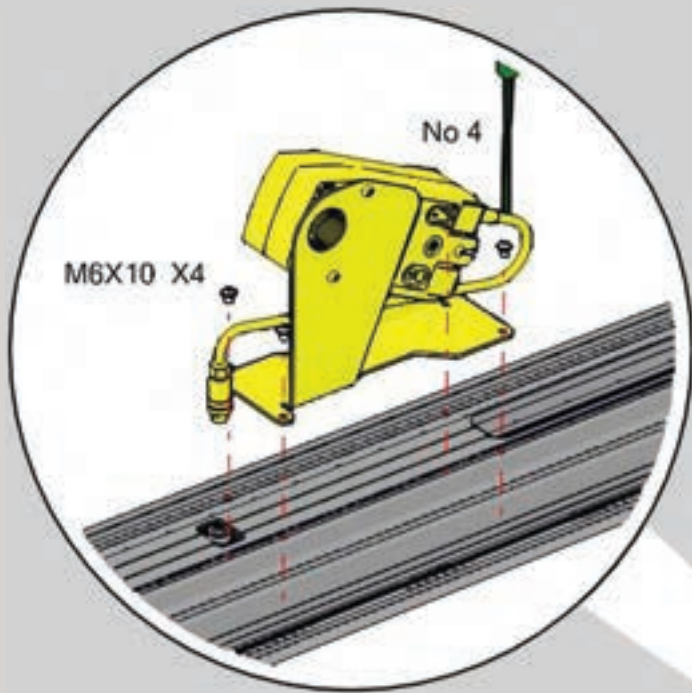

1 TEMPORARILY CLOSE LID AND ROTATE HOOP OVER ONTO FRONT

2 ALIGN THE BELIMO ACTUATOR WITH THE HOLES SHOWN ON THE HOOP HORIZONTAL AND FIX INTO PLACE

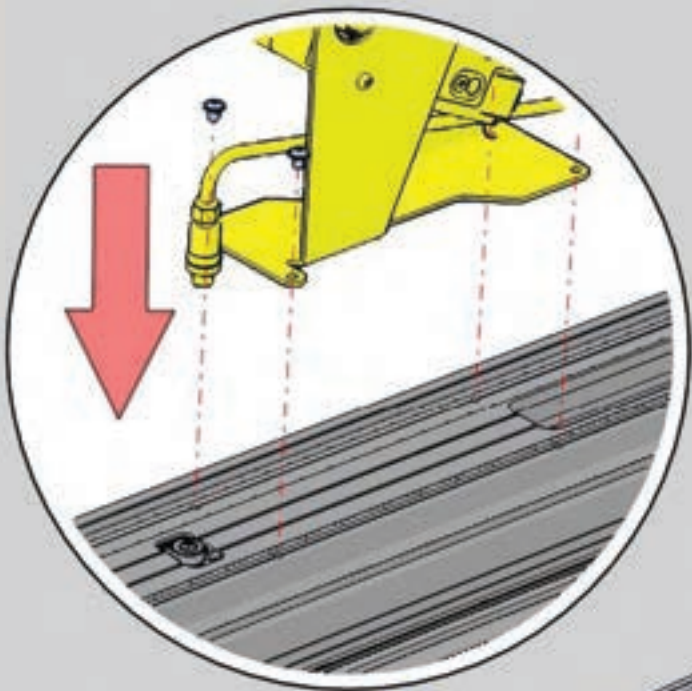

TORQUE
5NM (3.7 FT-LBF)

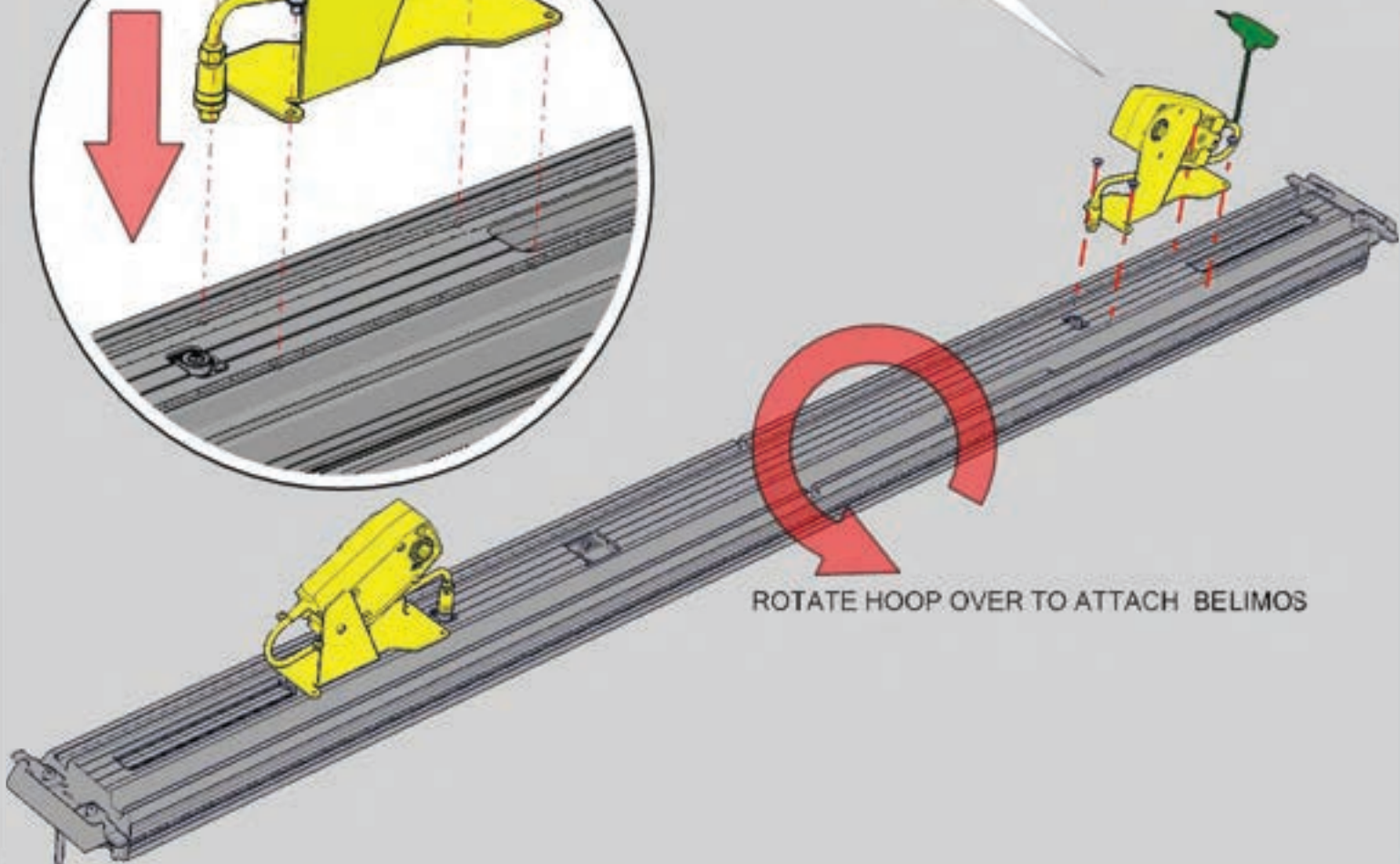

ROTATE HOOP OVER TO ATTACH BELIMOS



UPRIGHT A

 ONE PERSON MINIMUM

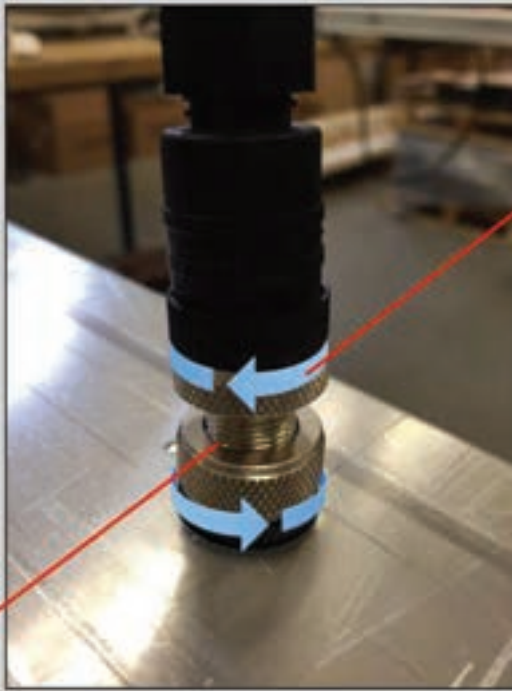

1

TWIST BOTH TOP AND BOTTOM TOGETHER AS SHOWN TO JOIN PLUGS TOGETHER

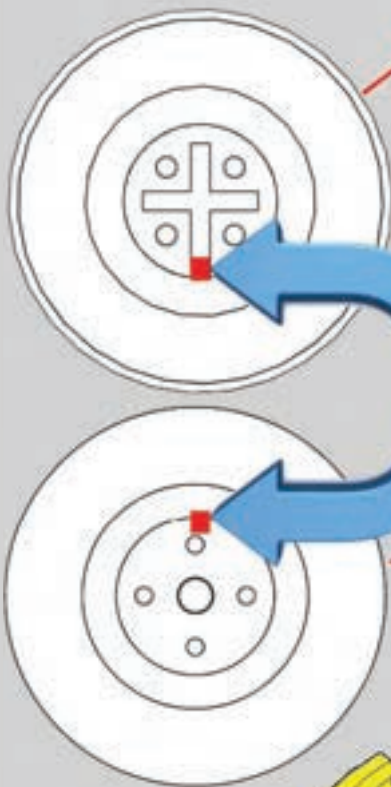

THESE 2 AREAS HIGHLIGHTED IN RED MUST ALIGN TOGETHER

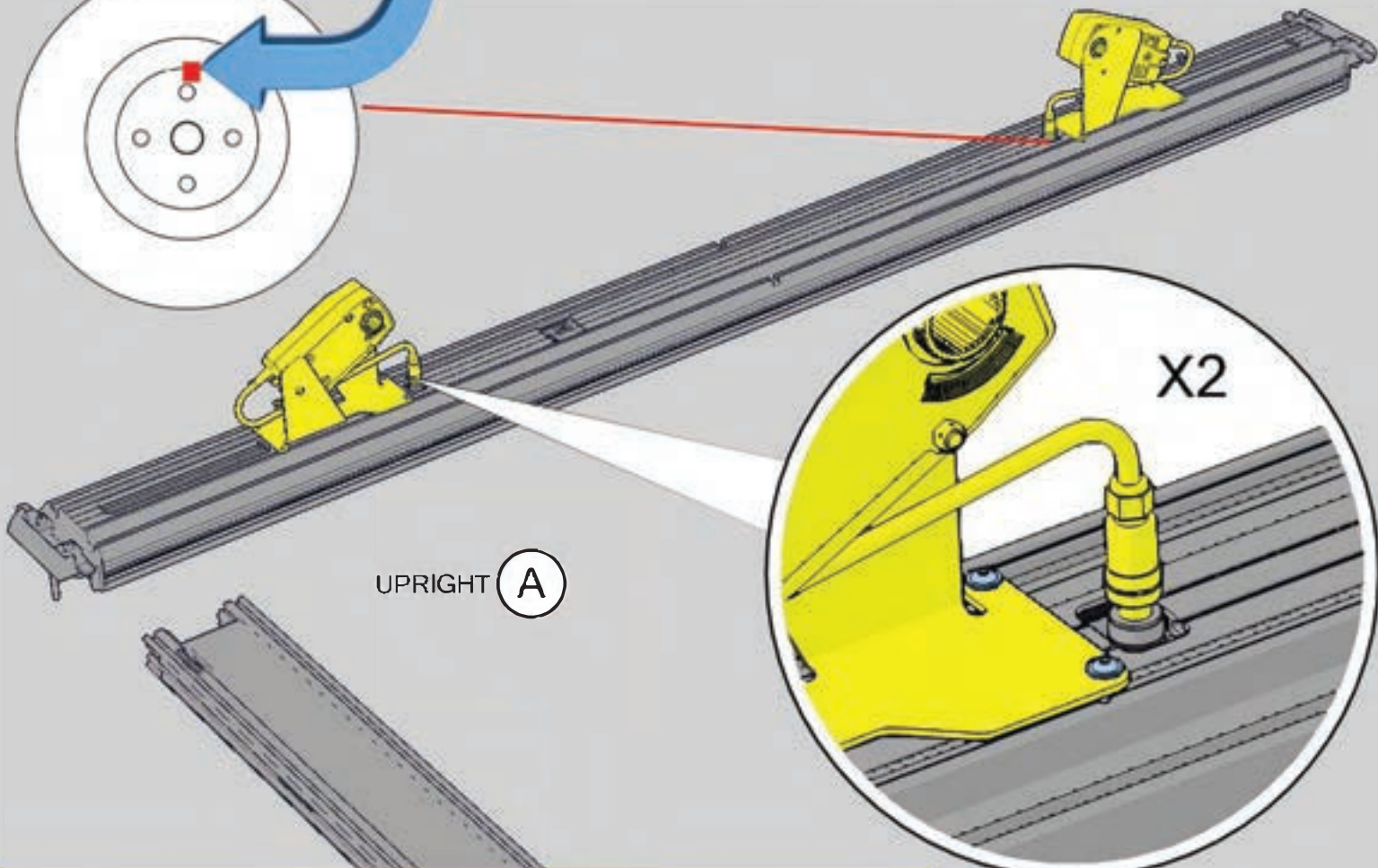

UPRIGHT (A)

X2



ONE PERSON MINIMUM

1

ATTACH ADHESIVE FOAM PAD

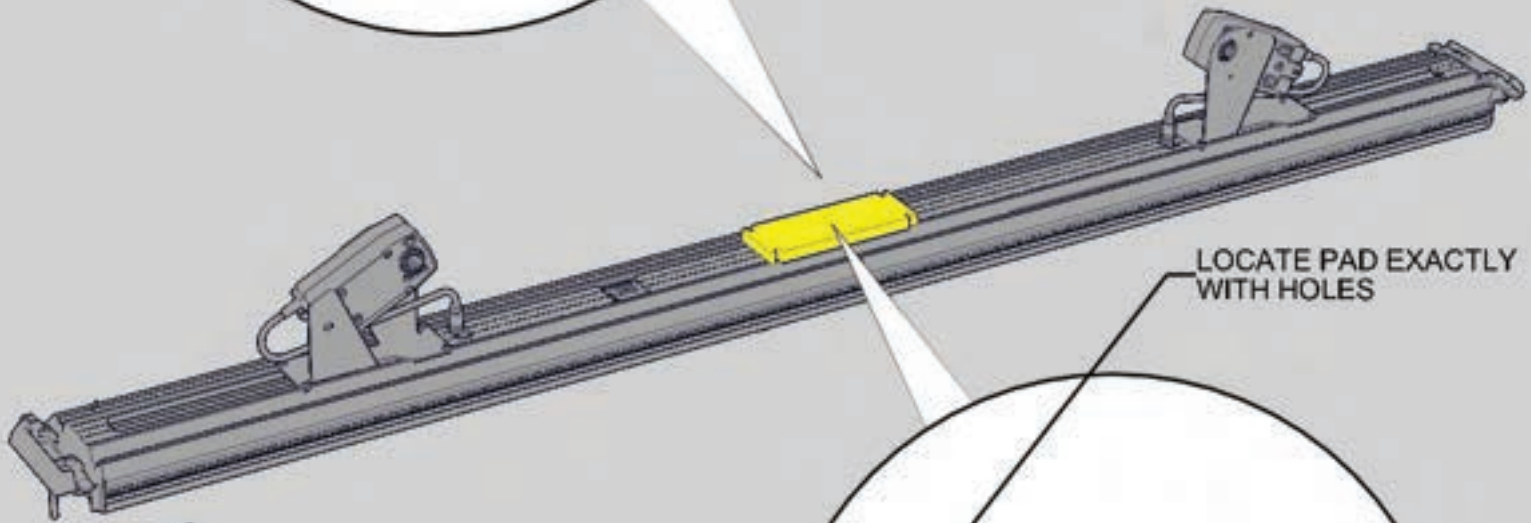
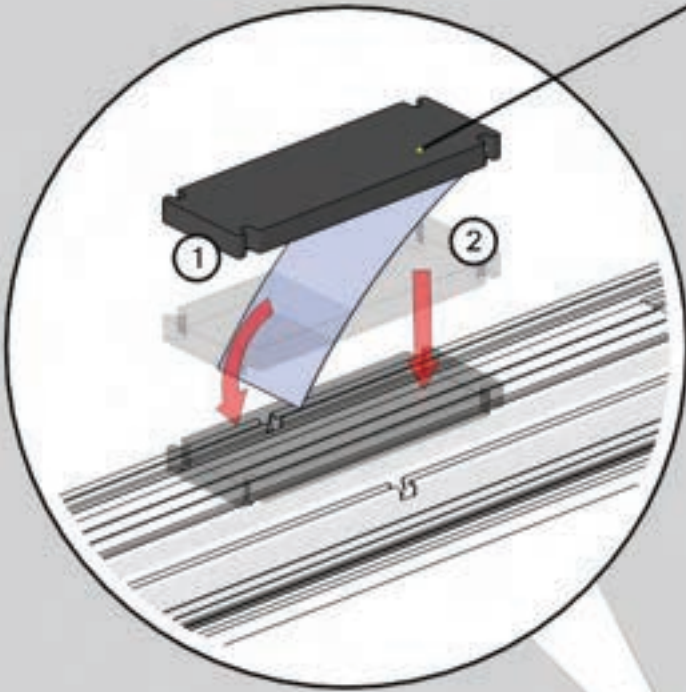

LOCATE PAD EXACTLY WITH HOLES

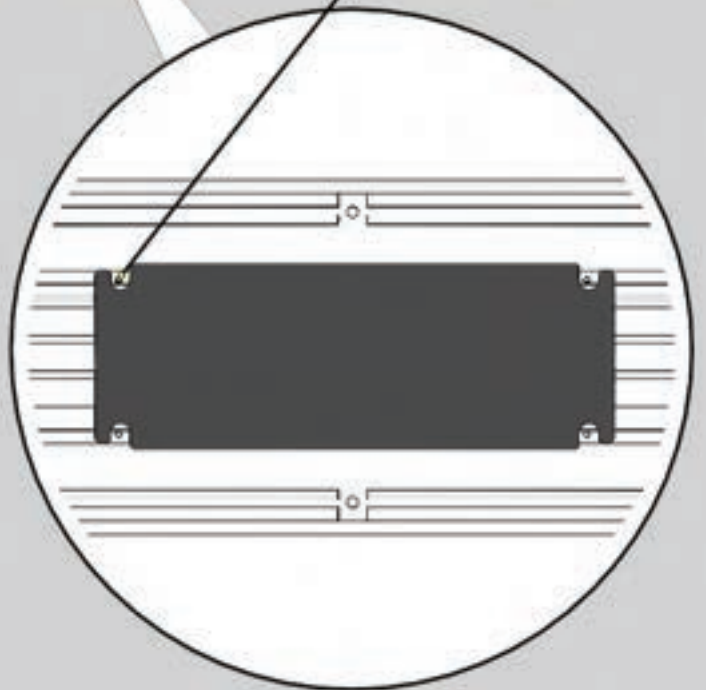

UPRIGHT (A)

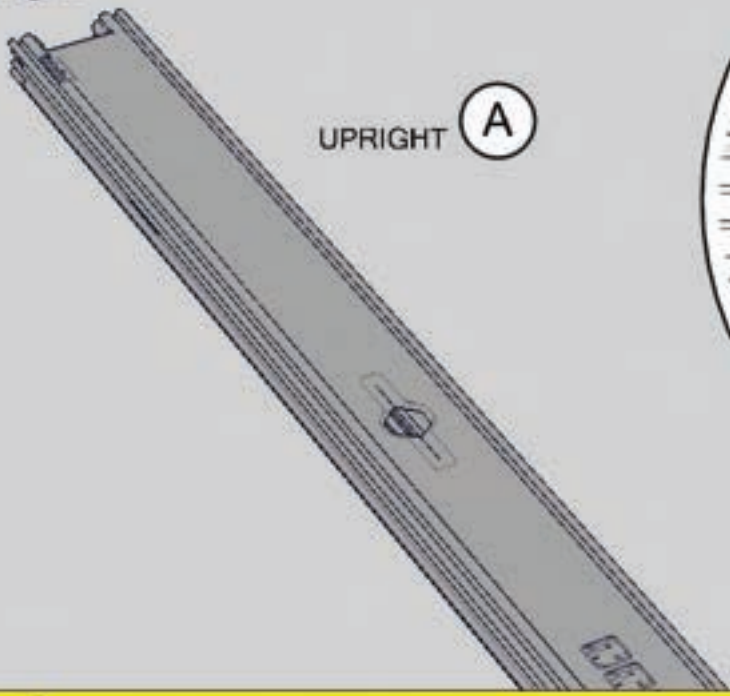

ONE PERSON MINIMUM

REMOVE THE BODY OF THE FAN FROM ITS BASE

USE A FLAT HEAD SCREWDRIVER JUST UNDERNEATH THIS TAB TO RELEASE THE STRAP. PUSH THE STRAP BACK AT THE SAME TIME TO RELEASE

1



2



3



4

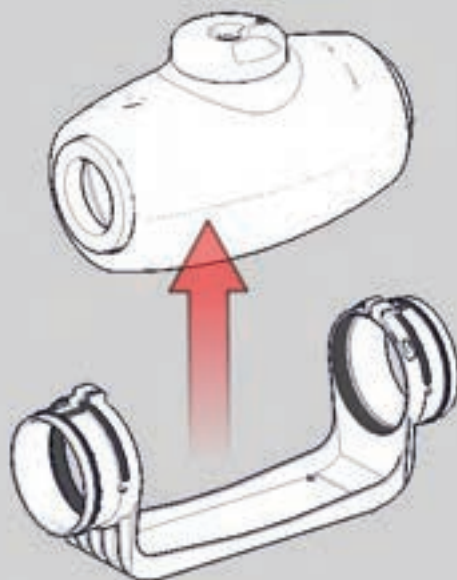

ONE PERSON MINIMUM

M4 LOCK WASHER X4

No 2.5

M4X30 BTN X4

TORQUE
3NM (2.21 FT-LBF)

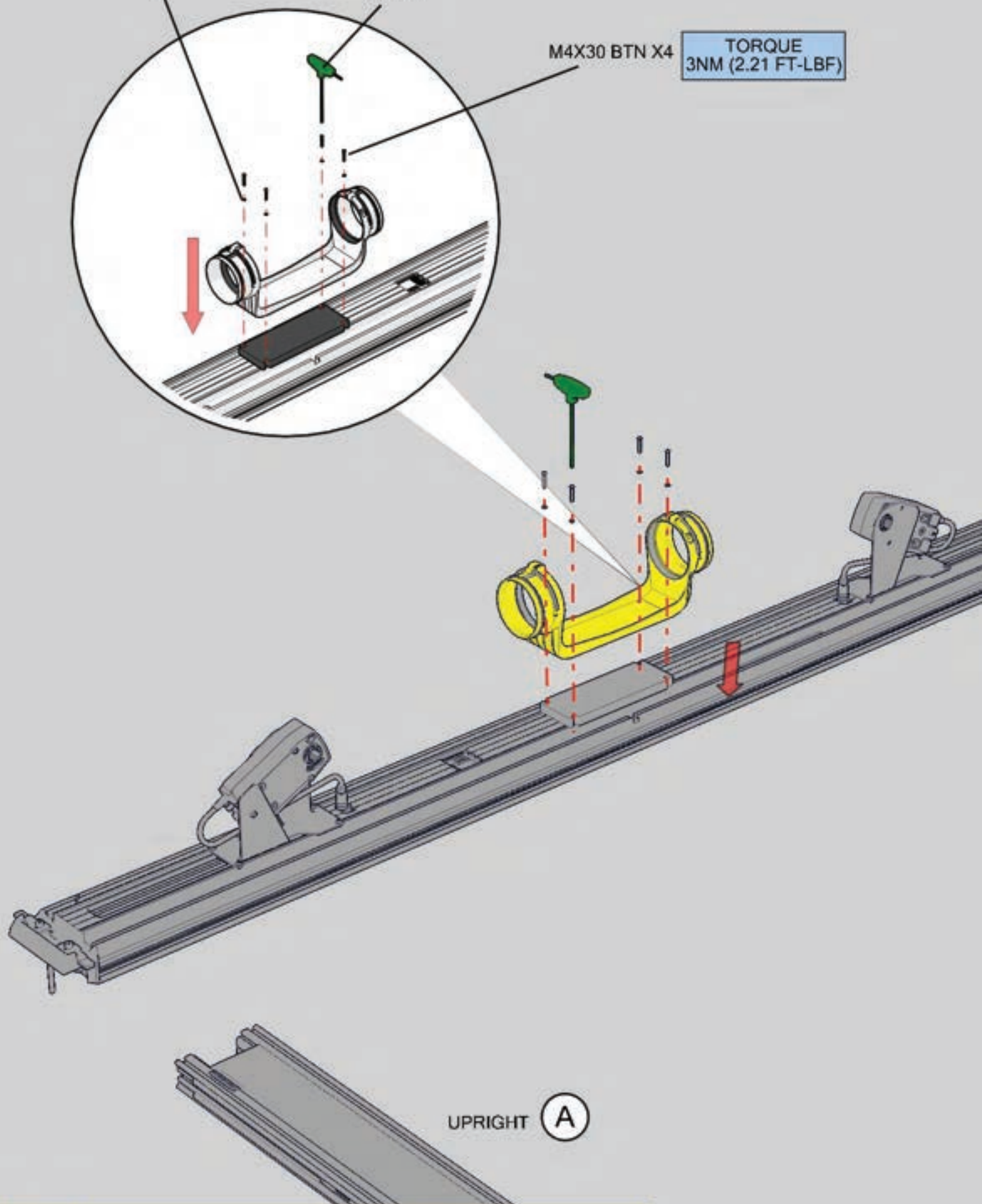

UPRIGHT

A

ONE PERSON MINIMUM

RE-ASSEMBLE THE BODY OF THE FAN TO THE BASE AND RE-STRAP

1



2



ENSURE THAT THE END WITH BLUE LABEL AND WHITE ARROW IS FACING THE AIR INLET SLOTS IN THE HOOP HORIZONTAL

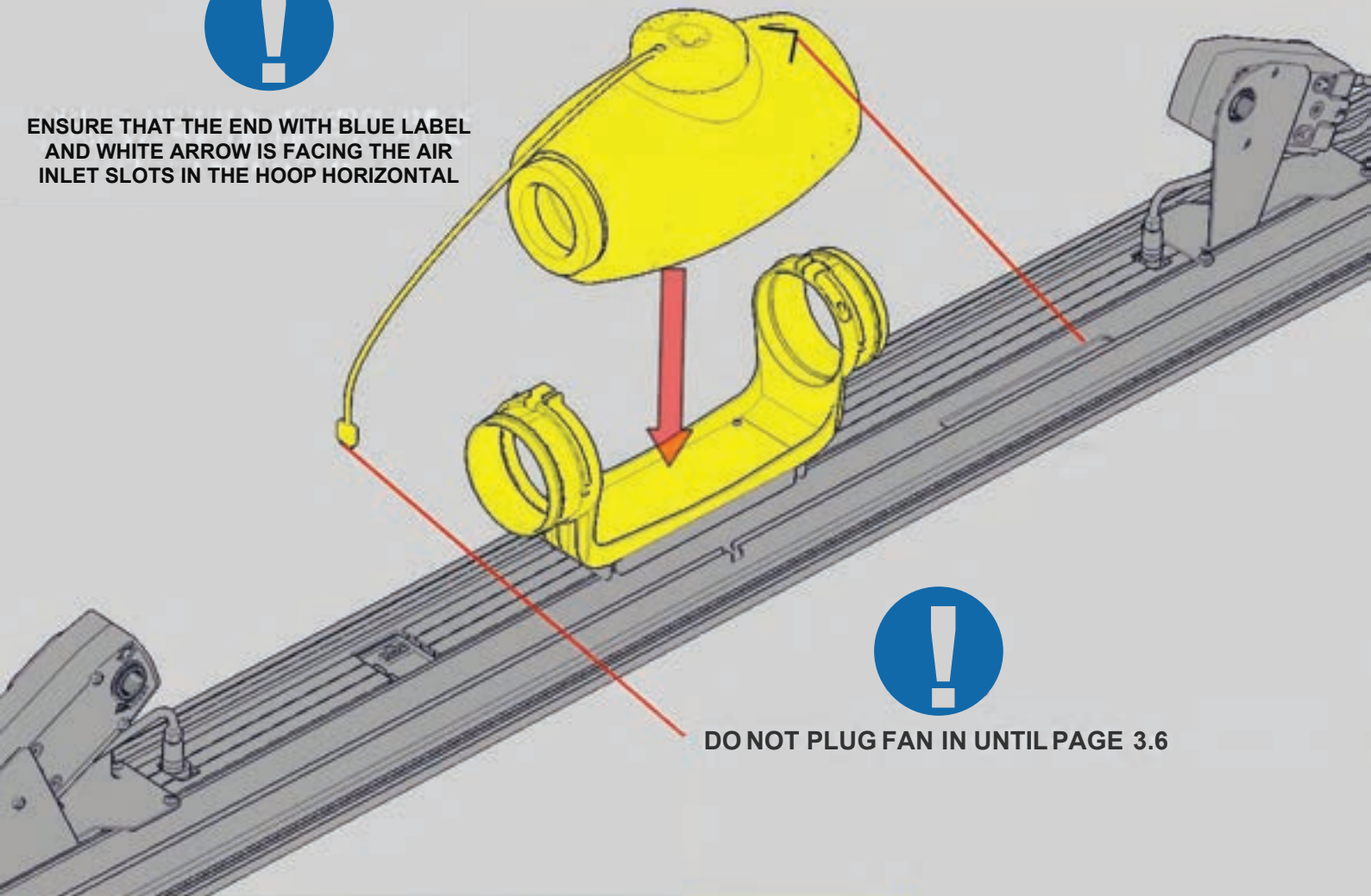

DO NOT PLUG FAN IN UNTIL PAGE 3.6



ONE PERSON MINIMUM

AMERICAS HEAT DETECTOR MOUNTING

AMERICAS HEAT DETECTOR INSTALLATION

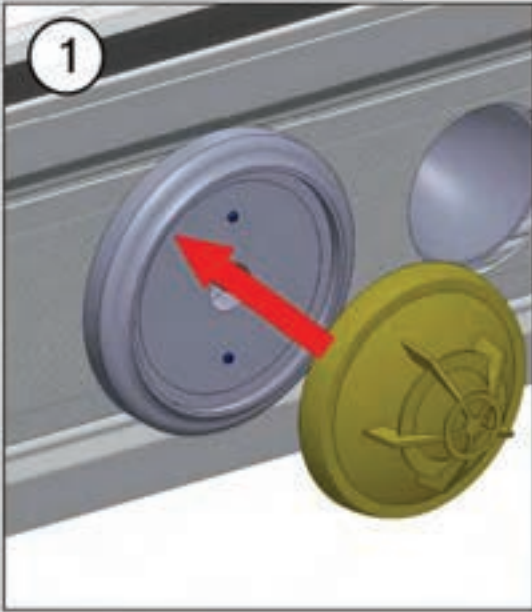

1

OFFER BODY UP TO ATTACHED
BASE

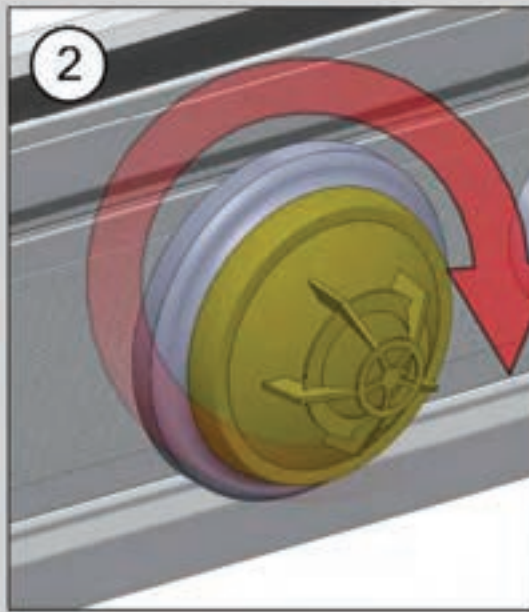

2

TWIST AND LOCK BODY ONTO
BASE

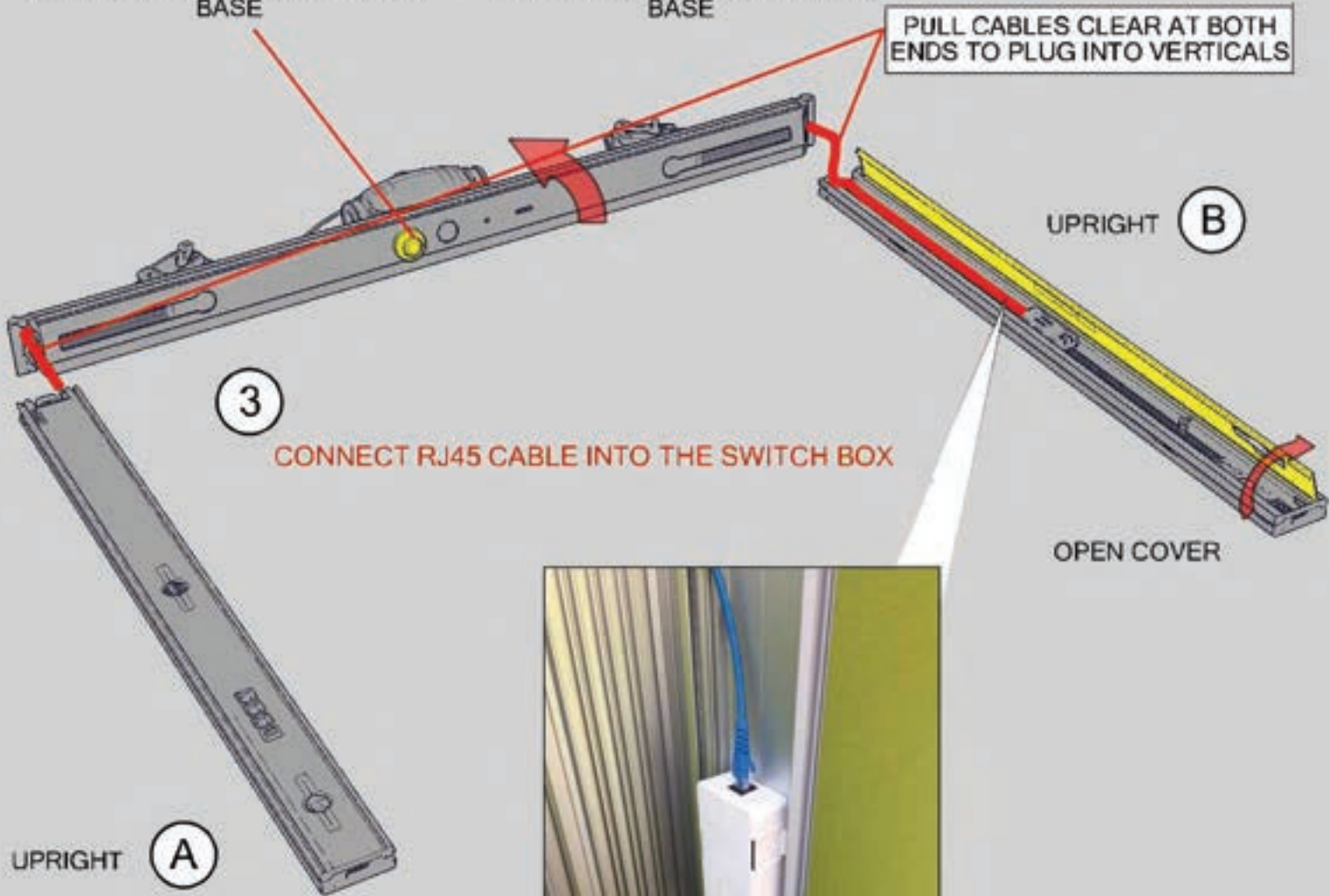

3

CONNECT RJ45 CABLE INTO THE SWITCH BOX

PULL CABLES CLEAR AT BOTH
ENDS TO PLUG INTO VERTICALS

UPRIGHT B

OPEN COVER

UPRIGHT A



NOTE: IF THERE ARE ANY ELECTRICAL
ISSUES WITH THE HOOP HORIZONTAL
REPLACE ENTIRE HORIZONTAL UNIT.
ONLY A QUALIFIED ELECTRICIAN TO
OPEN THE HOOP HORIZONTAL COVER



ONE PERSON MINIMUM

AMERICAS CONNECTIONS

1

CONNECT CABLE FROM POWER SOCKETS TO CABLE FROM LIGHT TRAY
THIS CONNECTION PROVIDES POWER TO THE HOOP HORIZONTAL
(MALE AND FEMALE CONNECTION)

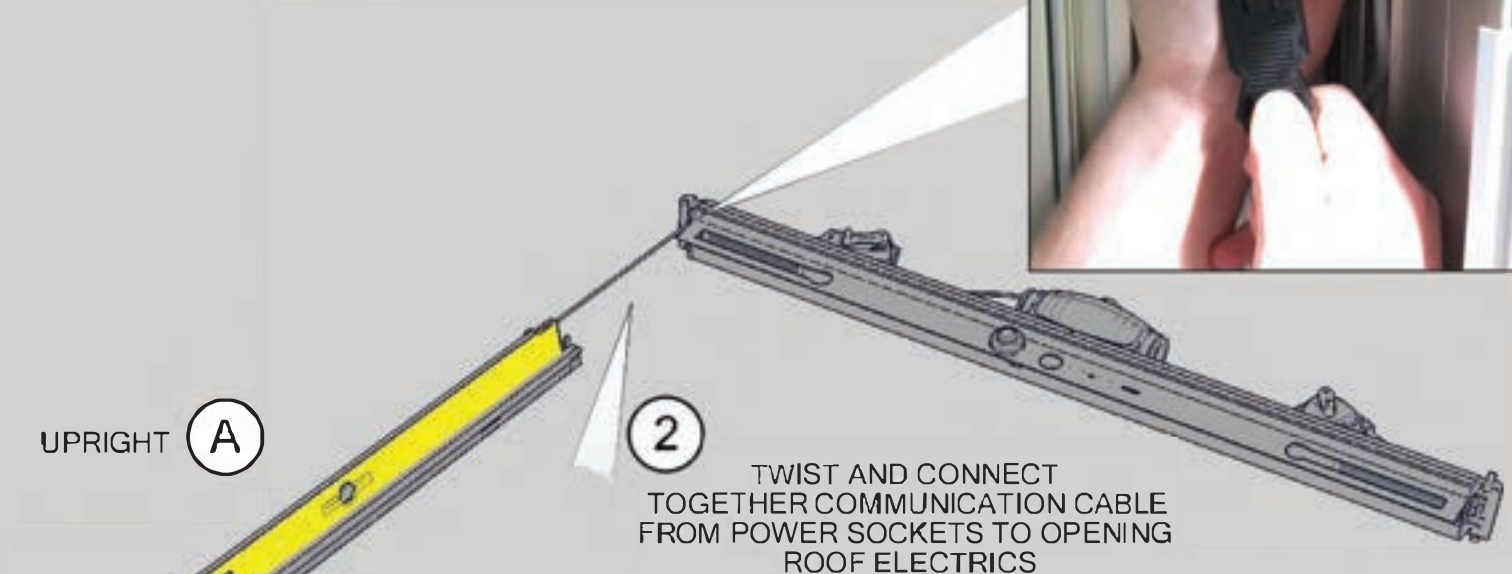

UPRIGHT **A**

2

TWIST AND CONNECT
TOGETHER COMMUNICATION CABLE
FROM POWER SOCKETS TO OPENING
ROOF ELECTRICS

OPEN COVER

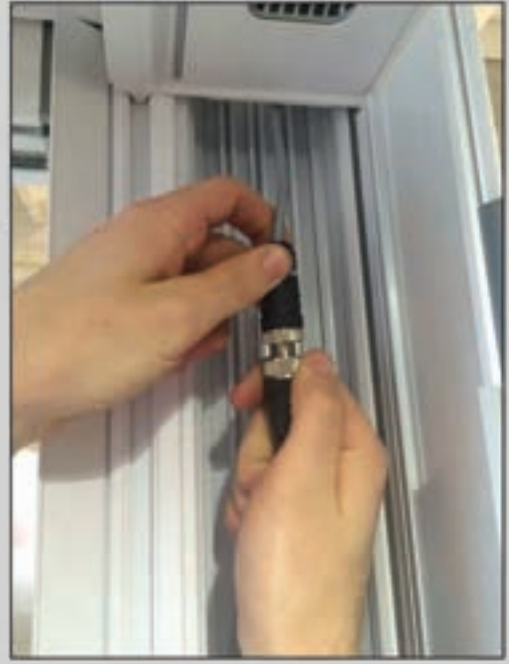

**CAUTION RISK OF ELECTRIC SHOCK
ALL ELECTRICAL CONNECTIONS MUST BE SECURED BEFORE THE POWER IS
SUPPLIED TO THE POD!!**



3

FOR CONNECTING POWER INTO POD PLEASE SEE PAGES 2.23 - 2.28 FOR VARIOUS
OPTIONS AVAILABLE



ONE PERSON MINIMUM

AMERICAS CONNECTIONS

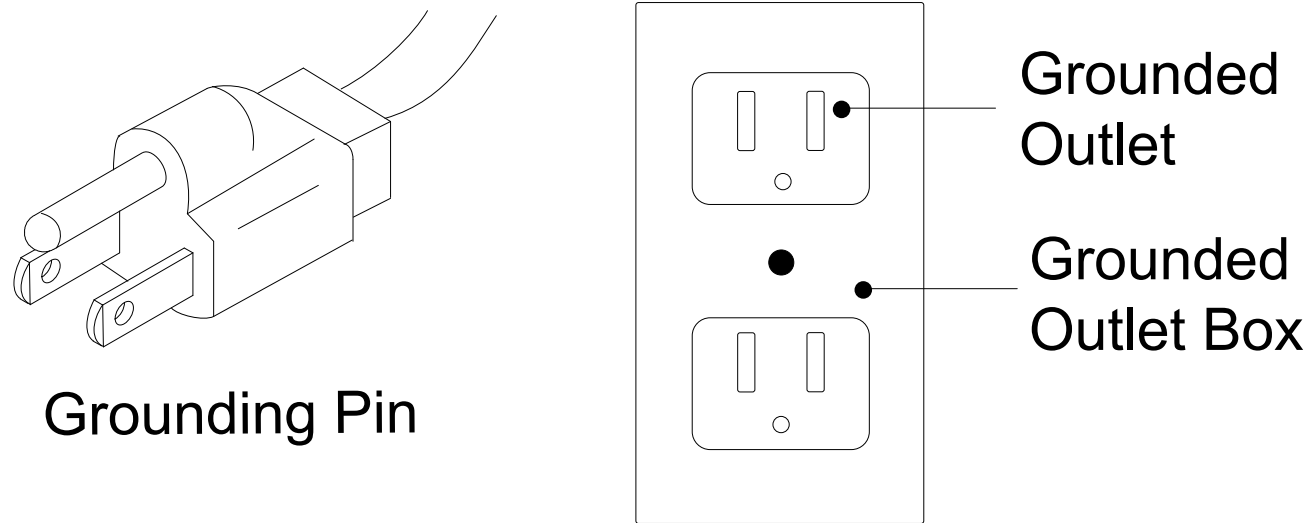

Fig. 1 Grounding Methods

Note: *Grounding, Cord-connection

This product is for use on a nominal 120-volt circuit and has a grounding plug that looks like the plug illustrated in (Fig. 1) Make sure that the product is connected to an outlet having the same configuration as the plug. No adapter should be used with this product.

*Grounding, Permanent Connection

This product must be connected to a grounded metal, permanent wiring system, or an equipment-grounding conductor must be run with the circuit conductors and connected to the equipment-grounding terminal or lead on the product.

POWER CONNECTION REFERENCE

OPENING ROOFS
AMERICAS POWER AND DATA

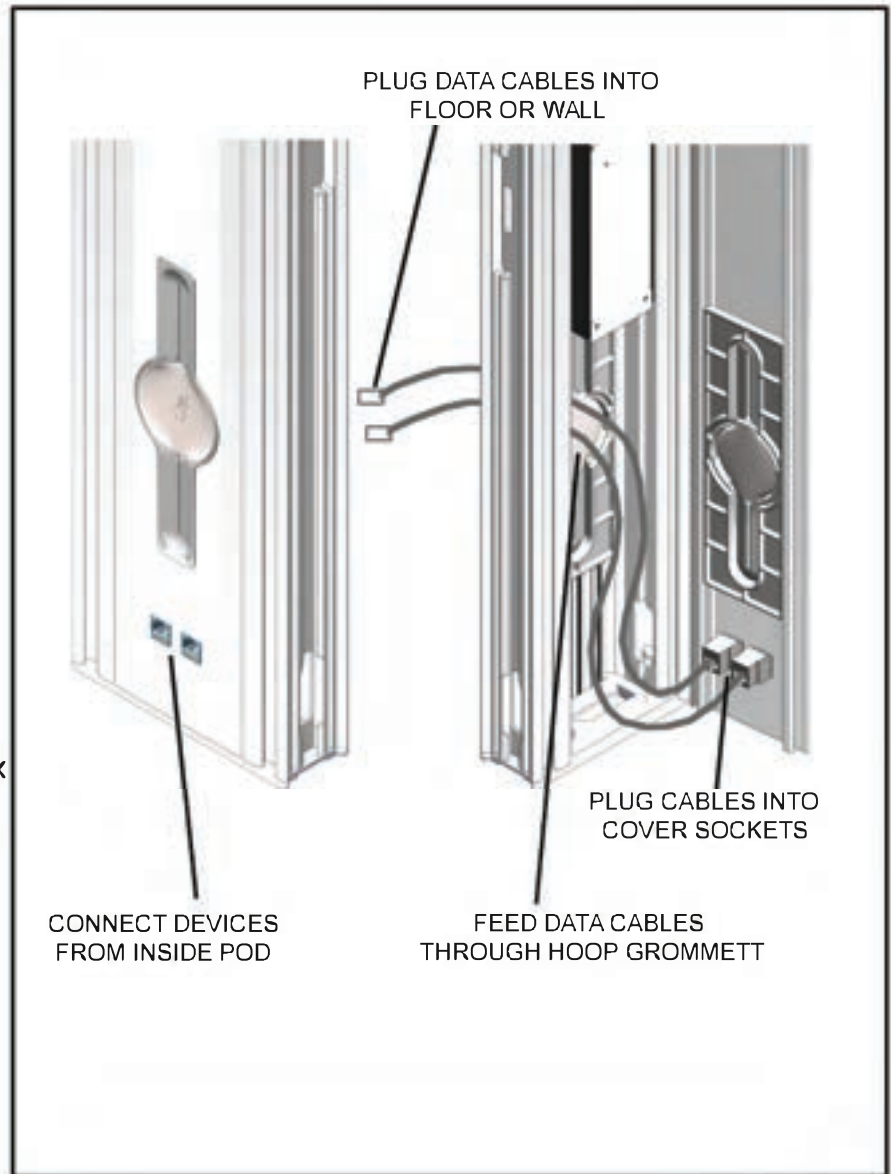

1

CLOSE ALL HOOP COVERS AND PRESS WITH PALM OF HAND TO CLOSE. ENSURE ALL CABLES ETC ARE TUCKED AWAY WHICH MAY PREVENT COVERS CLOSING PROPERLY



2

ROTATE UPRIGHTS ONTO SIDES. INSERT FIXINGS AND FULLY TIGHTEN

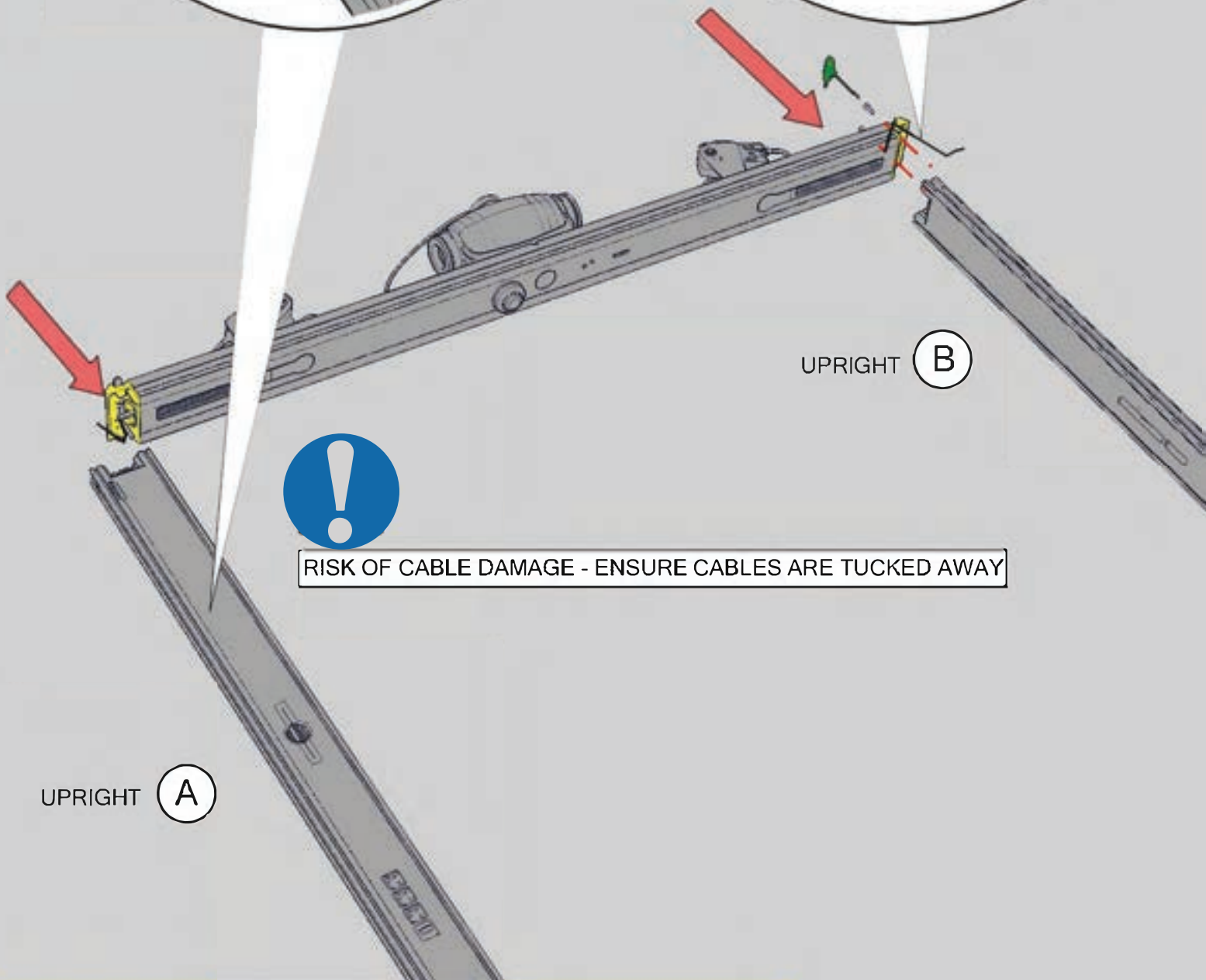
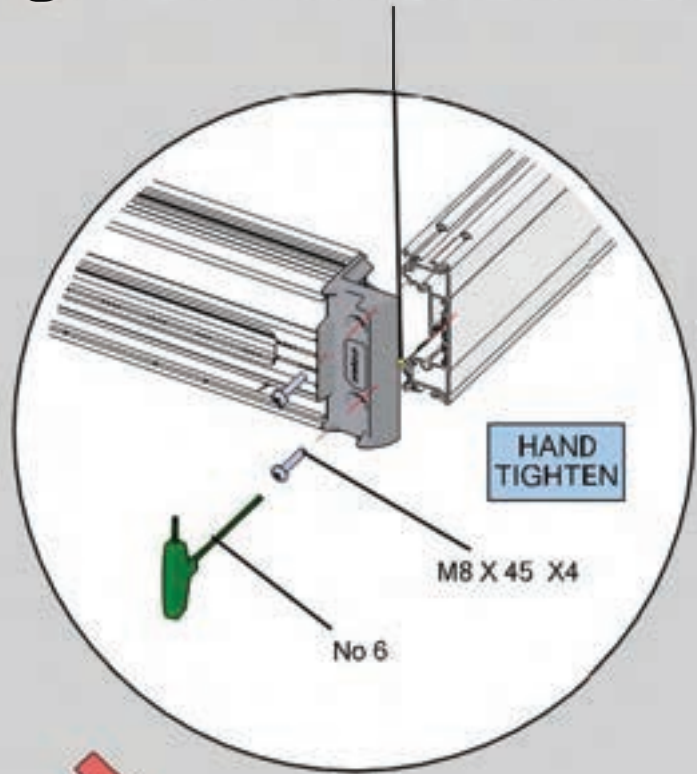

RISK OF CABLE DAMAGE - ENSURE CABLES ARE TUCKED AWAY

UPRIGHT A

UPRIGHT B



ONE PERSON MINIMUM

1

USING 2 PEOPLE, CAREFULLY STAND HOOP UPRIGHT AND SUPPORT

B

UPRIGHT

FRONT OF POD / DOOR

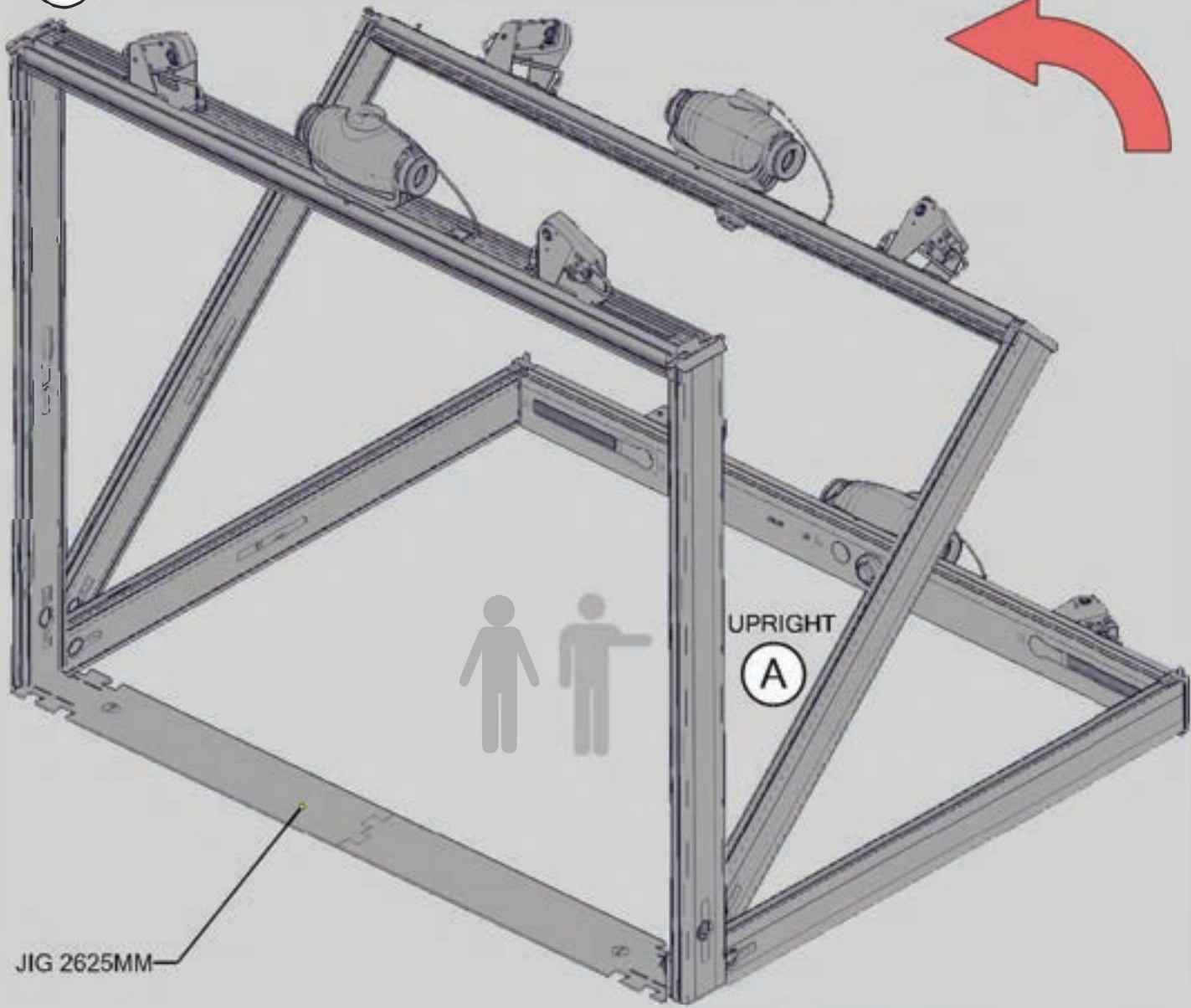

REAR OF POD

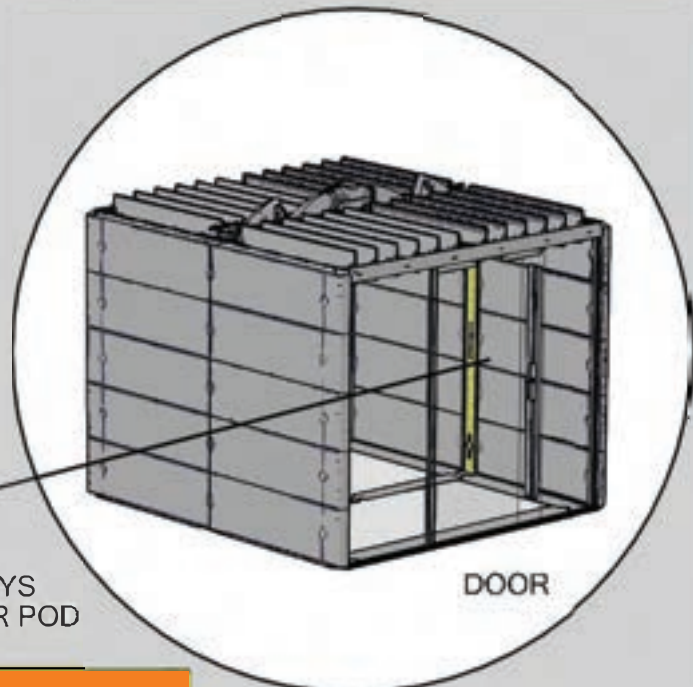

NOTE THAT THE SWITCH SIDE (UPRIGHT B) MUST ALWAYS BE NEAREST THE DOOR TO ADJUST LIGHTS AS YOU ENTER POD

DOOR

WARNING:  TWO PERSONS MINIMUM

Assembly sequence

Screens

section



Air-23



Air-25



Air-27

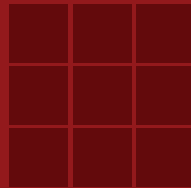

Air-29



* NO UNAUTHORISED PERSONNEL PERMITTED TO PARTICIPATE IN ASSEMBLY (ORANGEBOX CERTIFIED PERSONNEL ONLY)

*APPROPRIATE PPE MUST BE WORN AT ALL TIMES DURING ASSEMBLY OF ORANGEBOX PRODUCTS

*PART ASSEMBLED PODS MAY NOT BE LEFT UNATTENDED UNLESS STRUCTURALLY SOUND

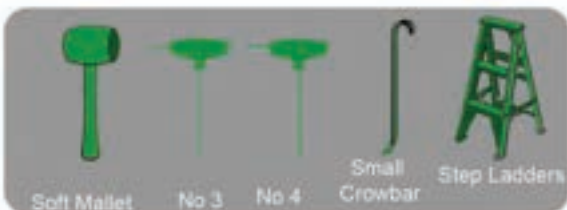

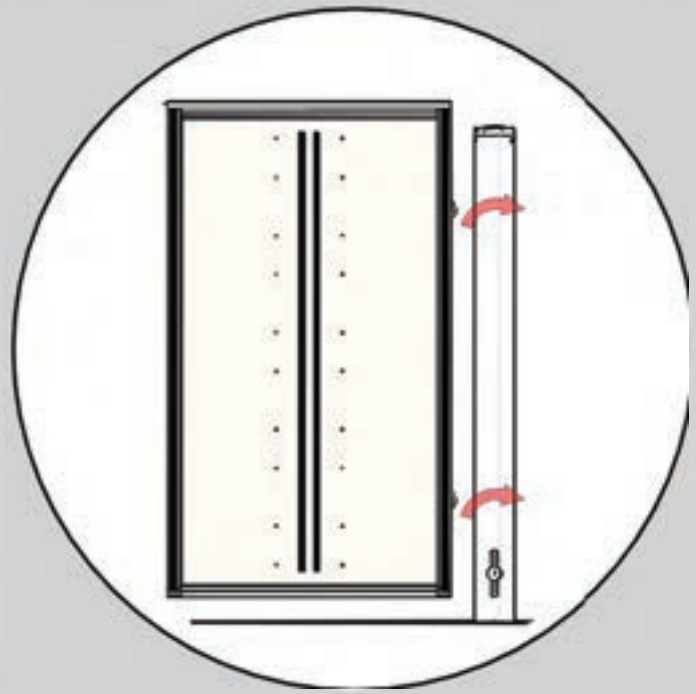
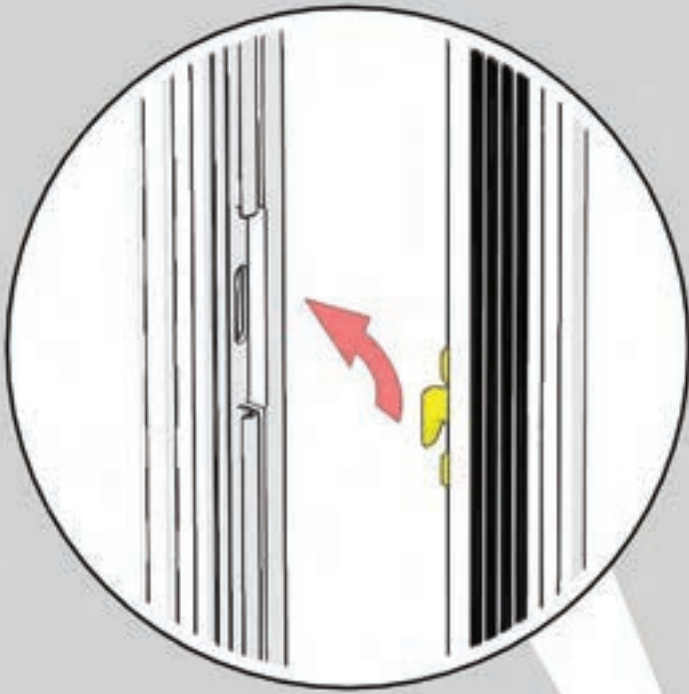

1 LIFT AND HOOK SCREENS INTO PLACE

USE NO 3 ALLEN KEY TO ADJUST HOOK POSITION IF REQUIRED (M6X20 GRUB SCREWS)

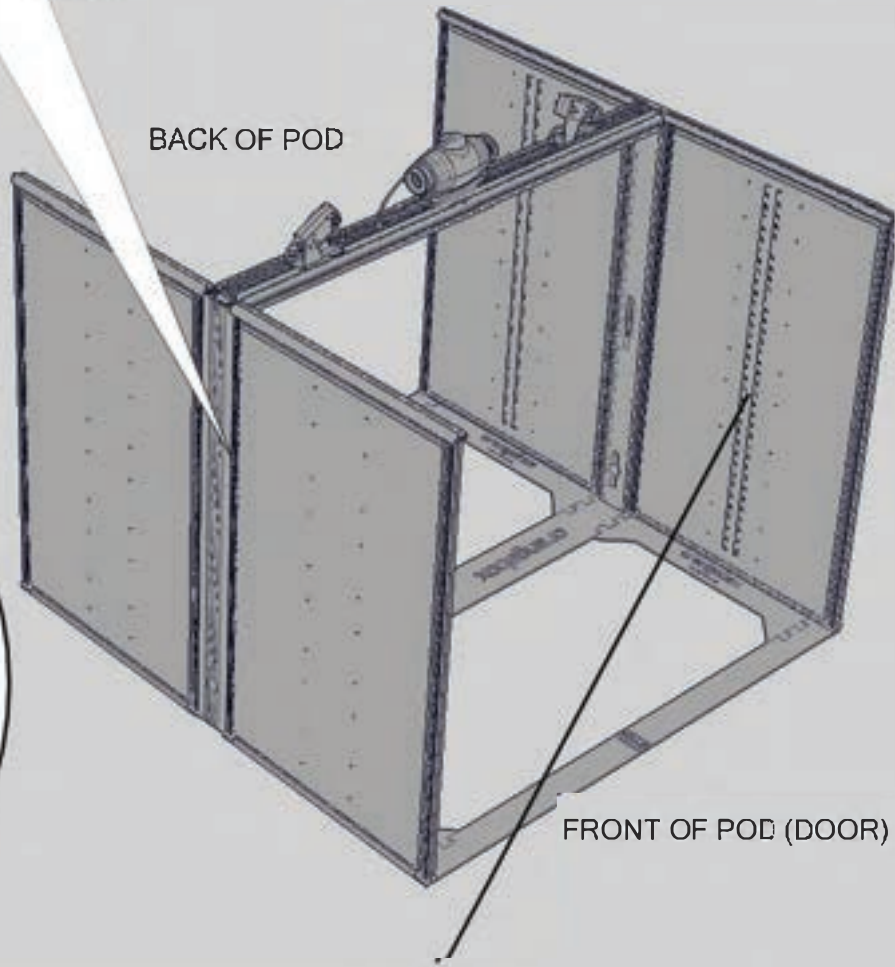

ENSURE HOOK IS LOCATED ON THE BOTTOM INDENTATION. SEE THE KNACK SECTION 10.4



TWO PERSONS MINIMUM

SEE PAGE 10.4

1

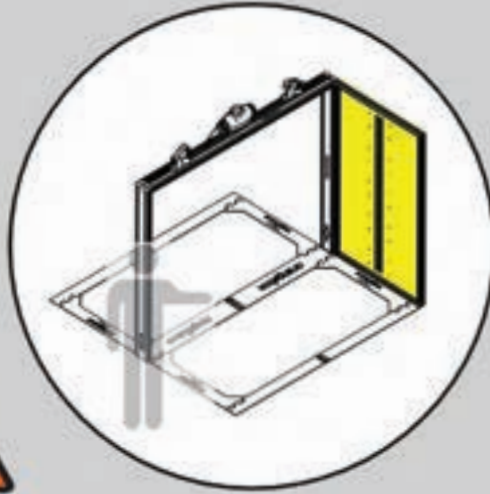

2



3

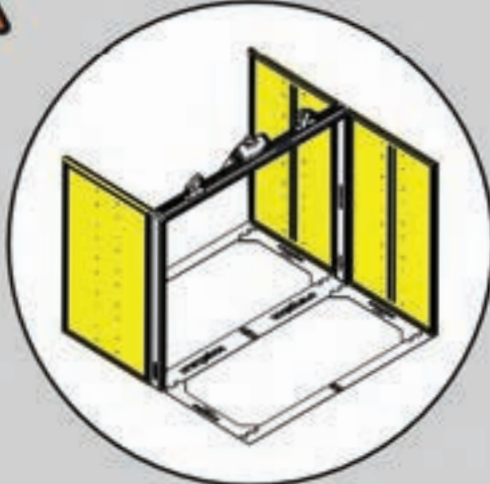

4



WARNING:  THREE PERSONS MINIMUM

TORQUE
14NM (10.32FT-LBF)

NO 5 ALLEN KEY

ANGLE ON SCREEN BRACKET SHOULD BE ANGLED DOWN
PLACING PRESSURE ON THE SCREEN

M8X45

BACK OF POD

FRONT OF POD (DOOR)

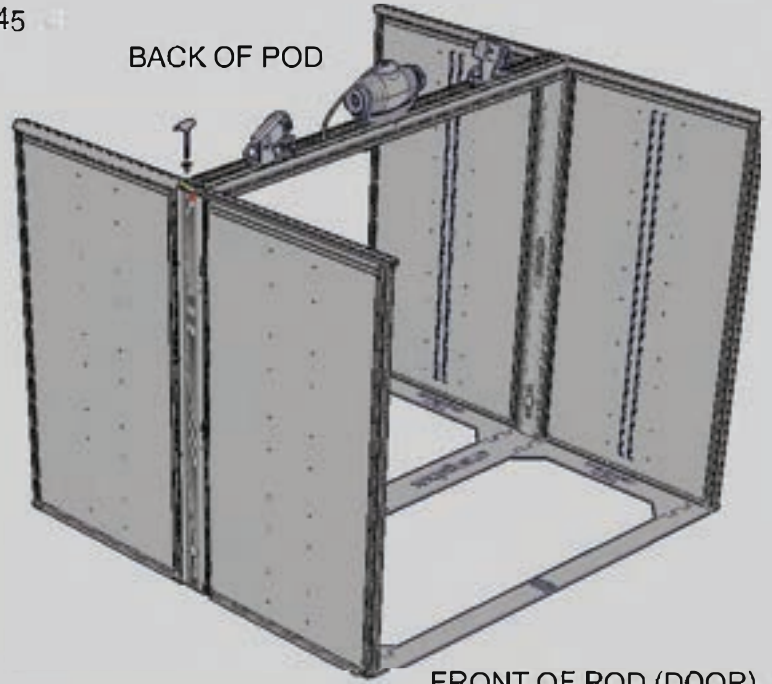
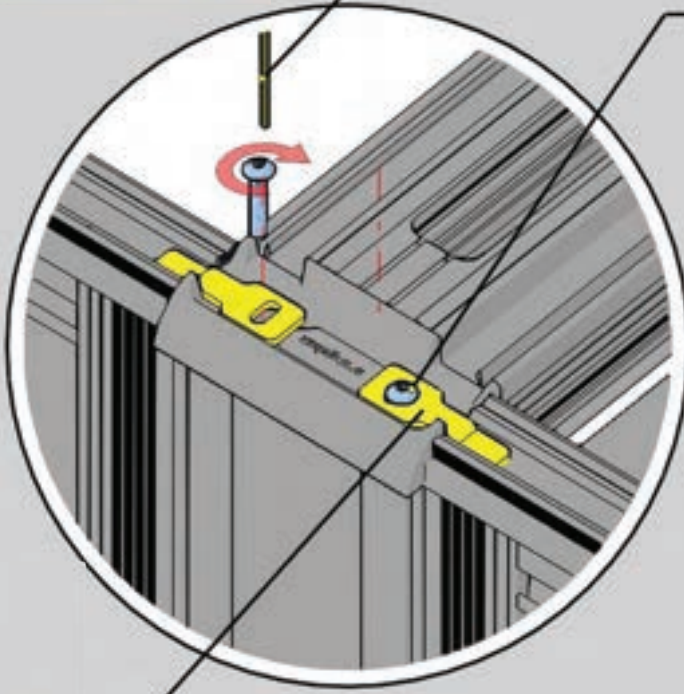

1

USE HOOP TO SCREEN BRACKETS X4
TO SECURE SCREENS AGAINST HOOP
(REMOVE FIXINGS ONE AT A TIME, FIT
BRACKET AND REPLACE AND FULLY TIGHTEN
FIXINGS)

2

SEE SECTIONS 10.4 - 10.7
USE CLAMPS AND SOFT MALLETS TO ADJUST SCREENS
AS REQUIRED

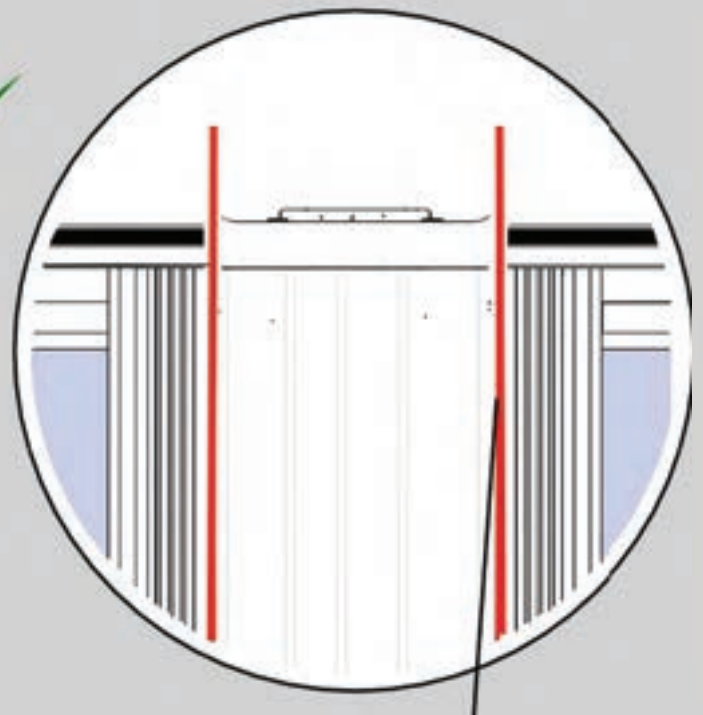
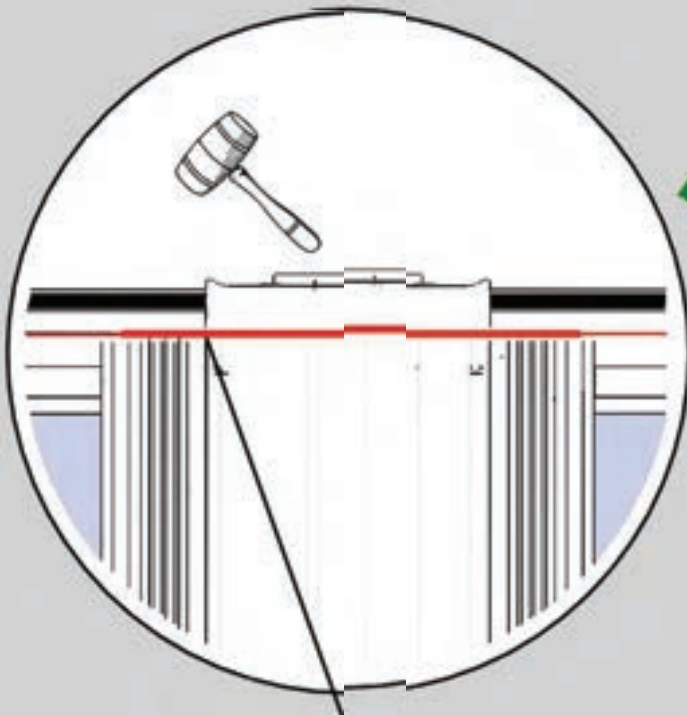

TOP OF BOTH SCREENS MUST BE IN LINE
WITH TOP OF HOOP

BOTH SCREENS MUST BE TIGHT UP
AND CLOSED AGAINST HOOP SIDES -
ALL THE WAY DOWN



TWO PERSONS MINIMUM

PAGE 10.4-10.5

3.4

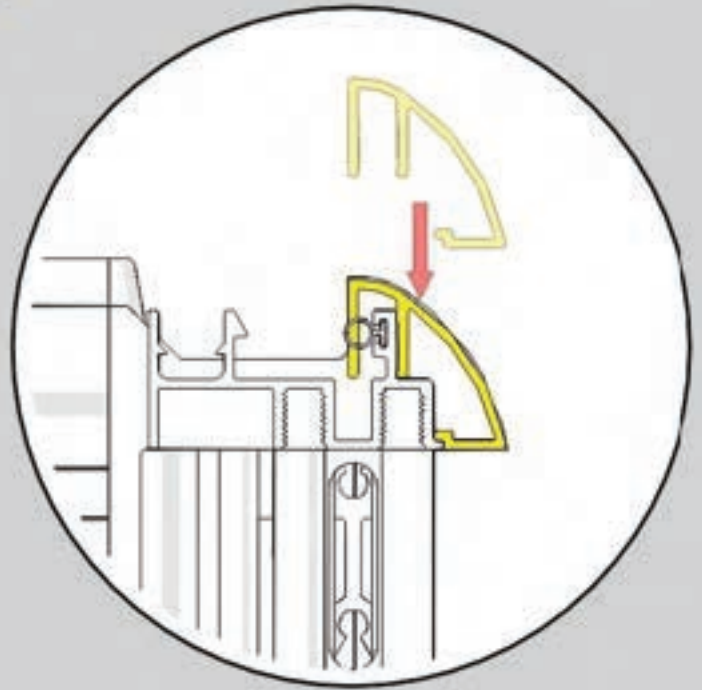
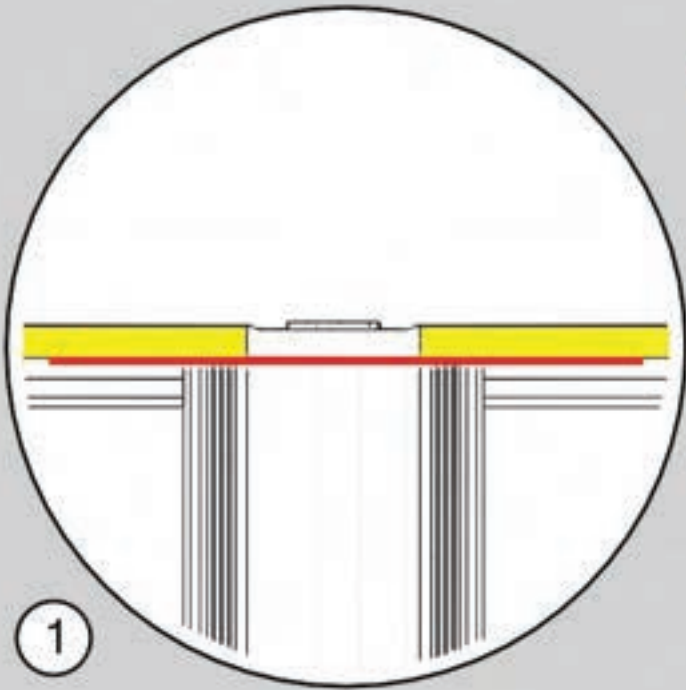

1

PUSH FIT TOP COVERS ONTO SCREENS AS A GOOD WAY TO CHECK ALIGNMENT OF SCREENS AGAINST EACH OTHER AND HOOP UPRIGHTS

HEIGHT AND CURVATURE OF COVERS MUST MATCH THAT OF CASTING

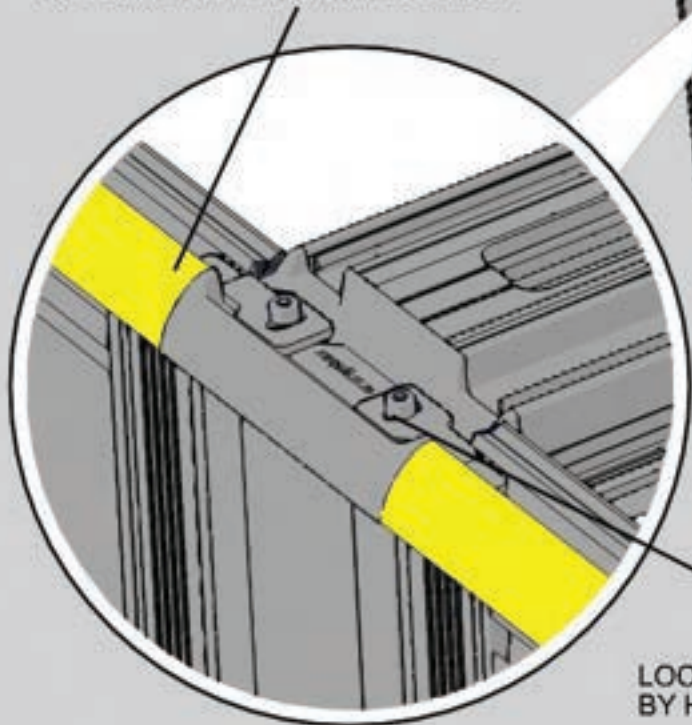

BACK OF POD

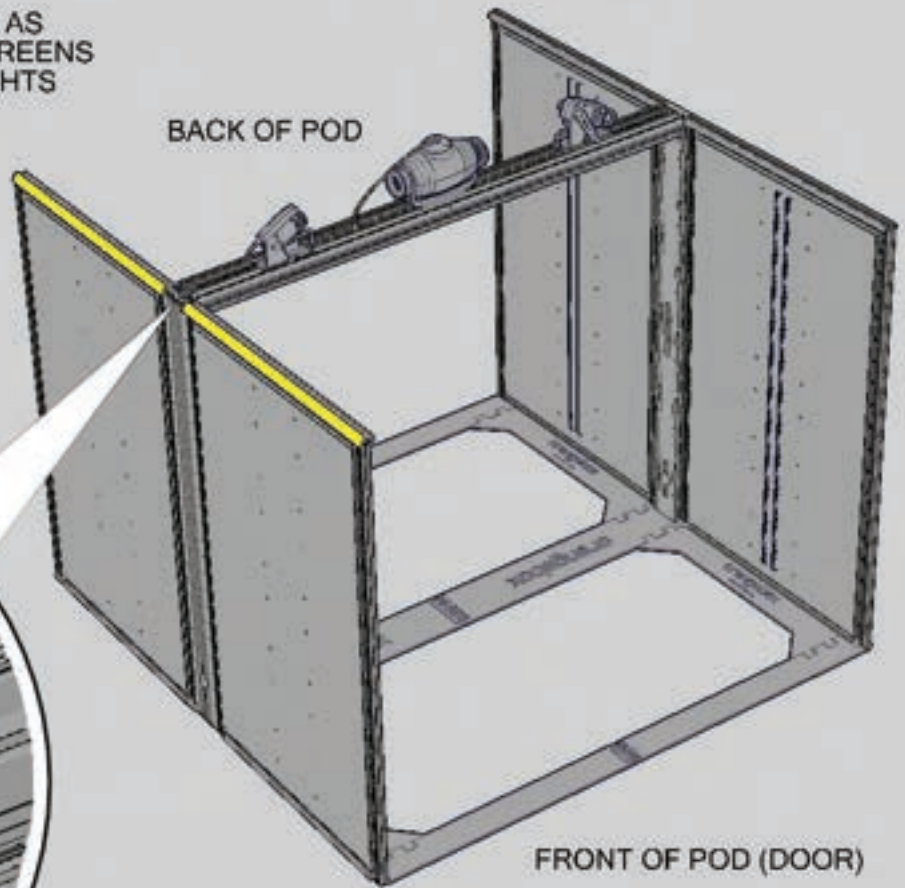

FRONT OF POD (DOOR)

LOOSEN FIXINGS / BRACKET AND ADJUST BY HAND IF NECESSARY



ONE PERSON MINIMUM

SEE THE KNACK PAGE 10.4 - 10.5

1

LOCATE FAN COWLS ONTO THE HOOP AND SNAP FIT INTO PLACE

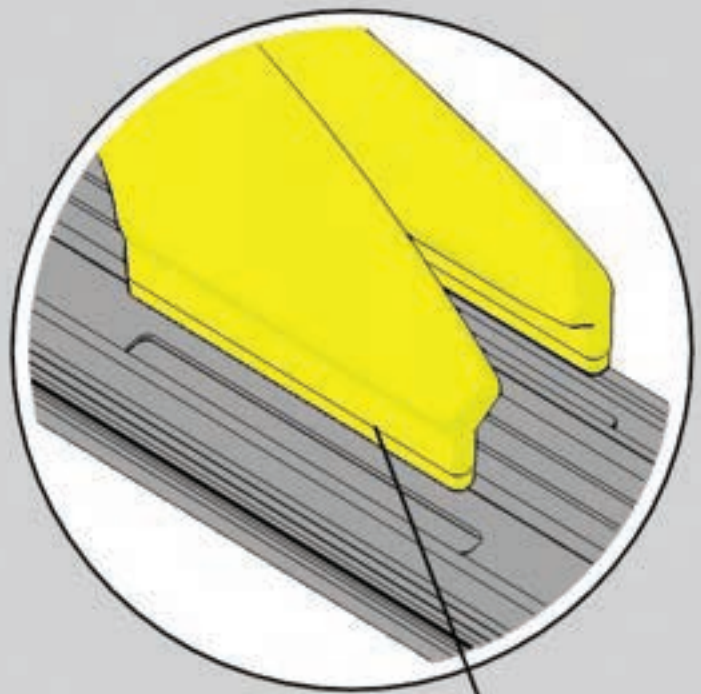

NOTE THAT THE COWL WITH THE EXTENDED ENDS MUST FIT INTO THE SLOTS IN THE EXTRUSION

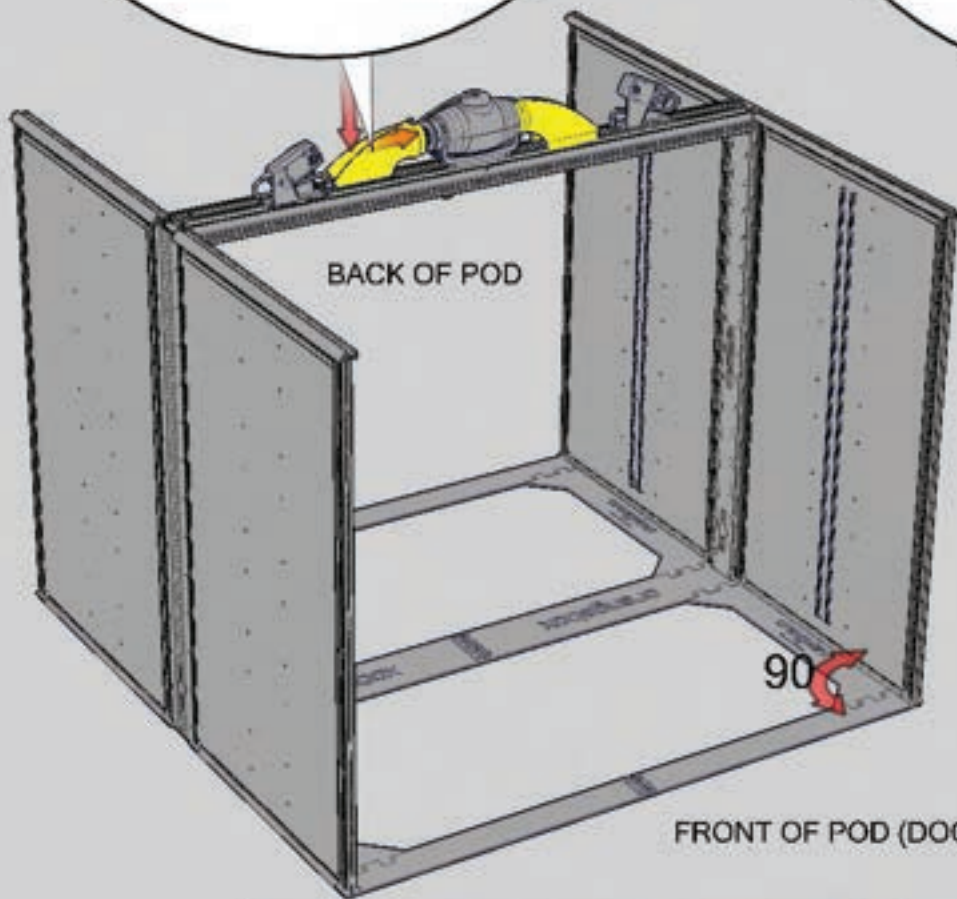

2

PLUG FAN CABLE INTO PORT AS SHOWN BELOW ENSURE FAN CABLE IS POSITIONED AS SHOWN ABOVE

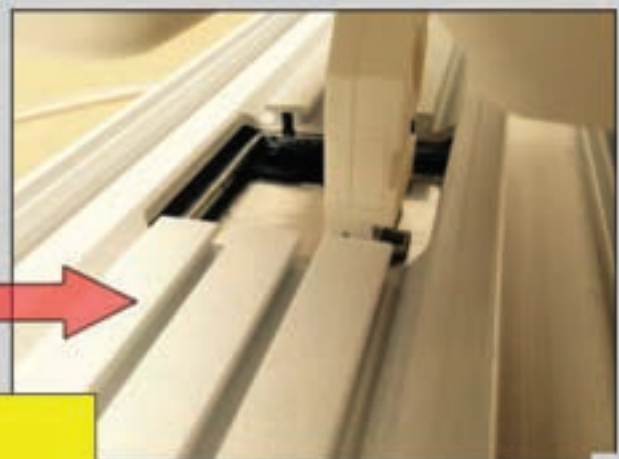

ONE PERSON MINIMUM

Assembly sequence

Front & back glass frames

section

4

* NO UNAUTHORISED PERSONNEL PERMITTED TO PARTICIPATE IN ASSEMBLY (ORANGEBOX CERTIFIED PERSONNEL ONLY)

* APPROPRIATE PPE MUST BE WORN AT ALL TIMES DURING ASSEMBLY OF ORANGEBOX PRODUCTS

* PART ASSEMBLED PODS MAY NOT BE LEFT UNATTENDED UNLESS STRUCTURALLY SOUND



1 LOCATE TOP CROSSBAR INTO UPRIGHTS AND HAND TIGHTEN

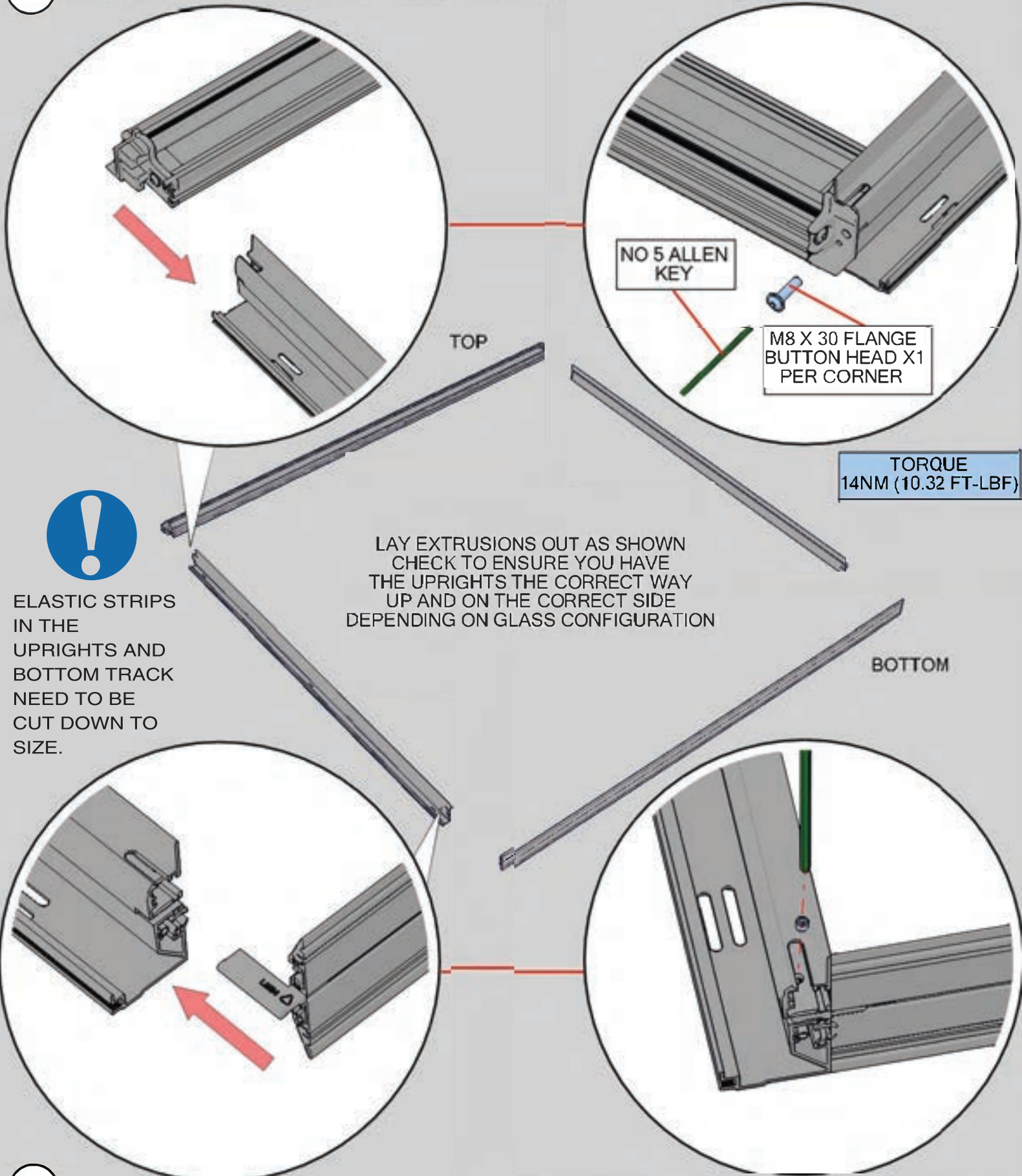

2 LOCATE BOTTOM CROSSBAR INTO UPRIGHTS AND HAND TIGHTEN GRUBSCREW TO LOCK POSITION



ONE PERSON MINIMUM

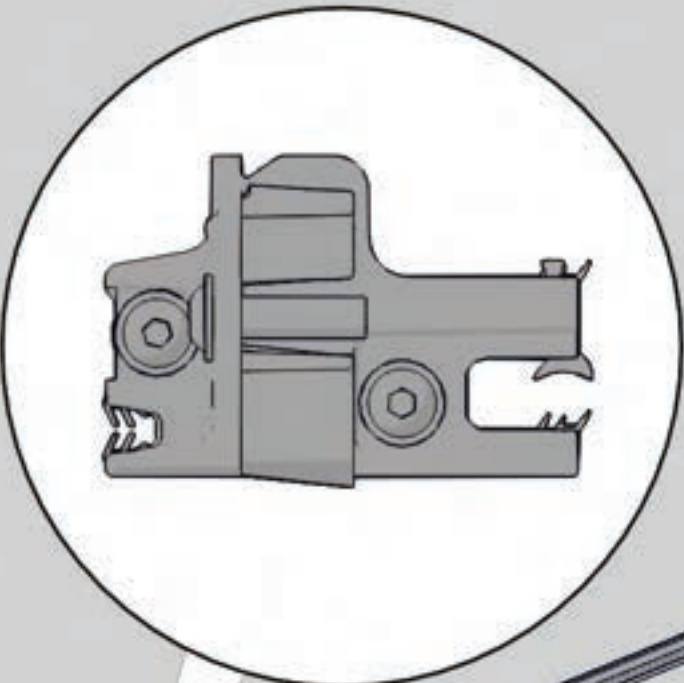

TOP

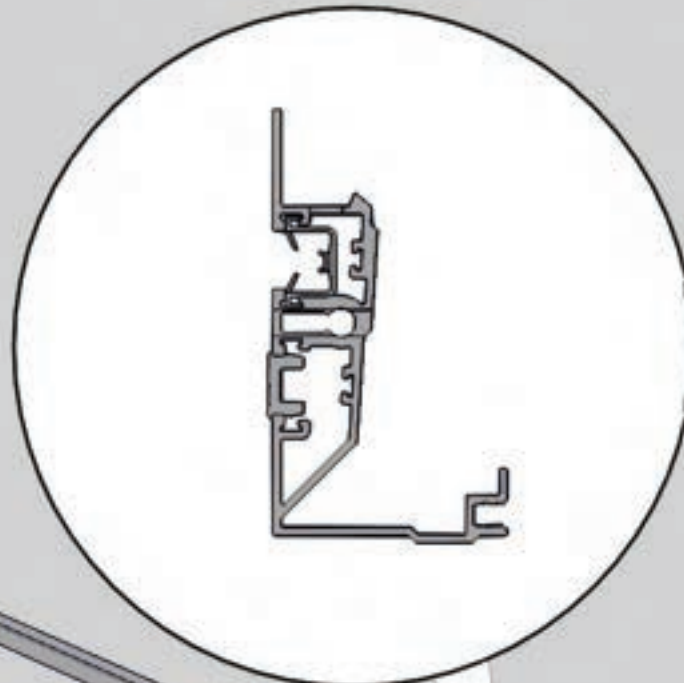

FRONT FRAME ASSEMBLY

BOTTOM

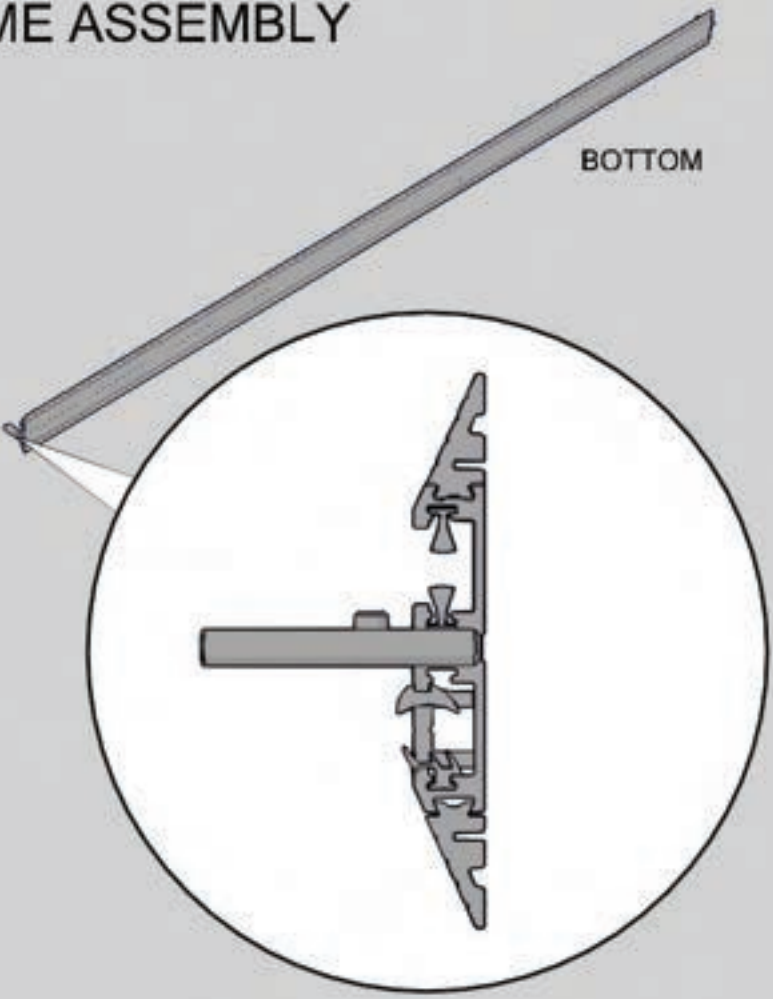
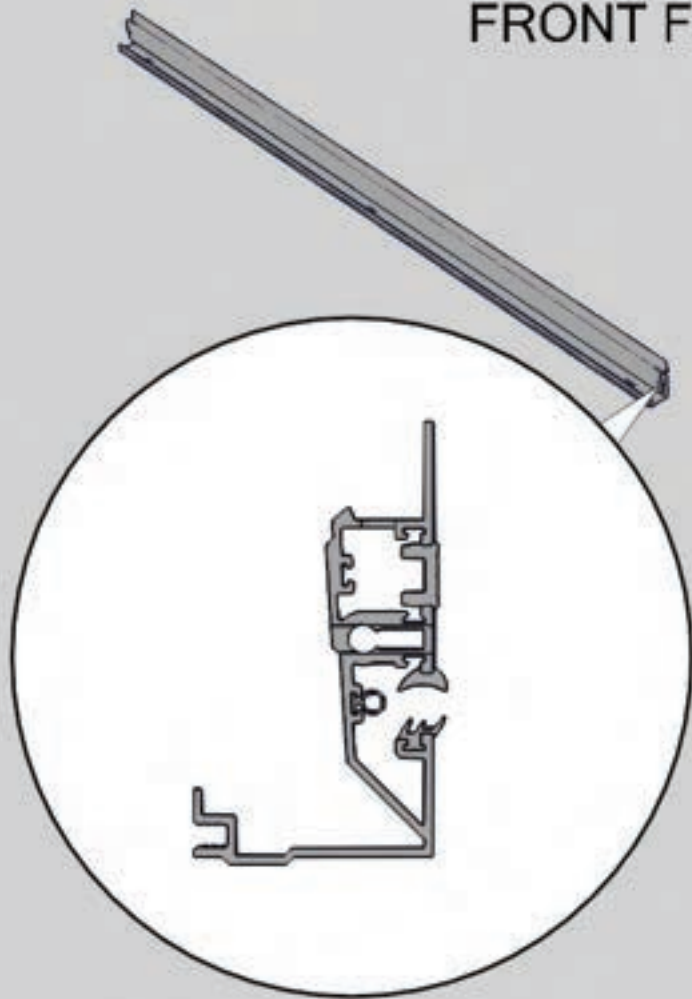

ONE PERSON MINIMUM

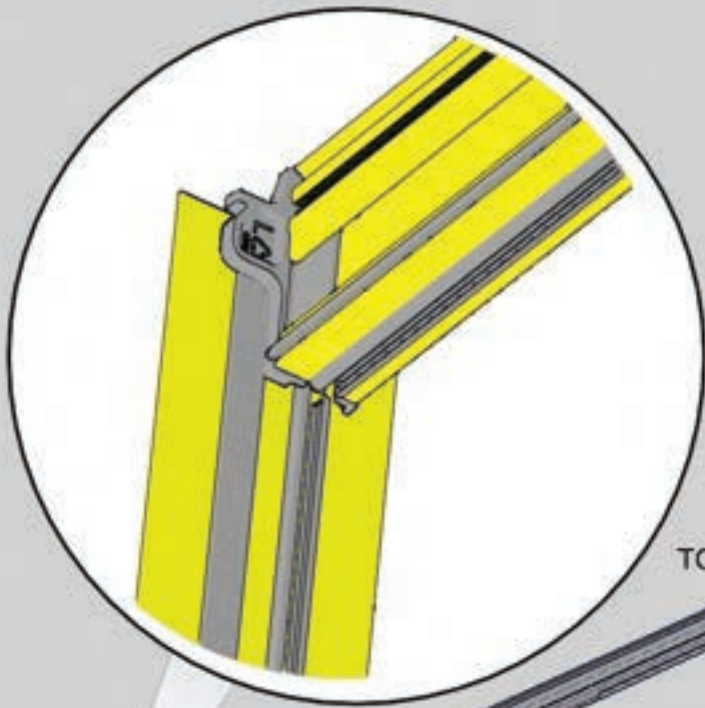

(SAME CONNECTION IN BOTH TOP CORNERS)

TOP

FRONT FRAME ASSEMBLY

BOTTOM

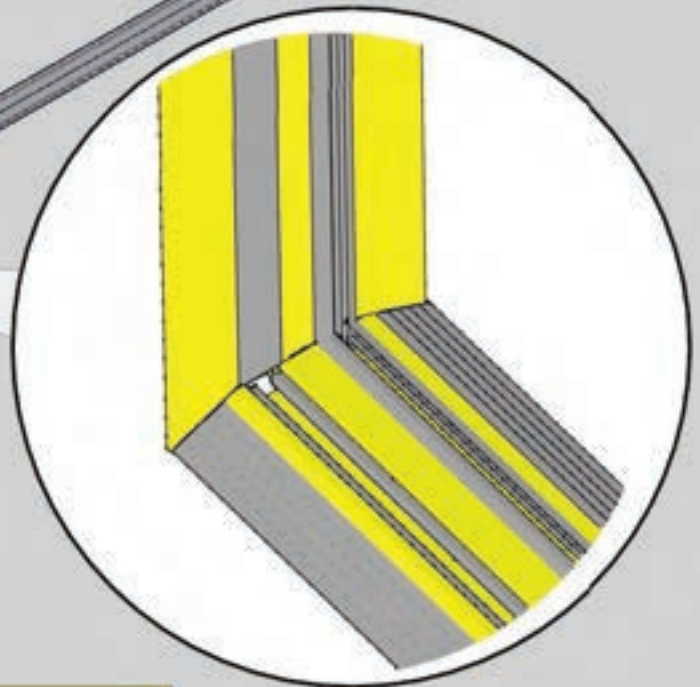

(SAME CONNECTION IN BOTH BOTTOM CORNERS)



ONE PERSON MINIMUM

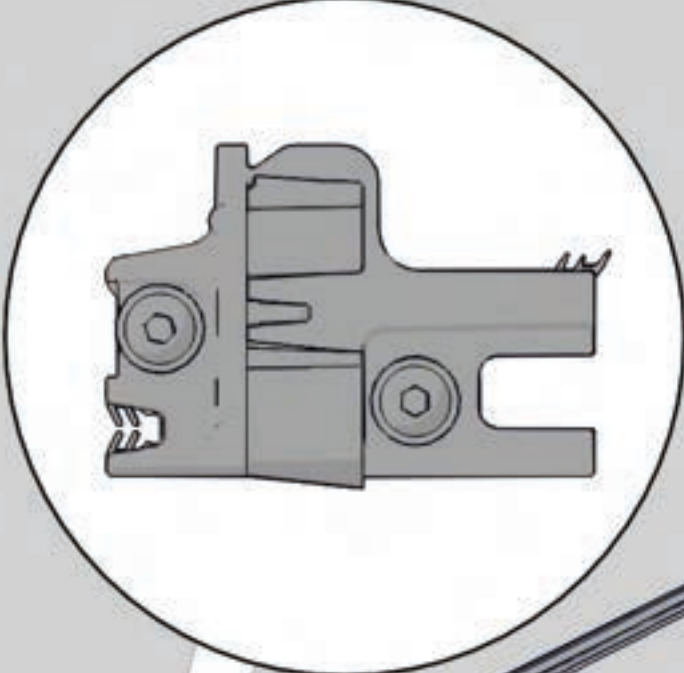

TOP

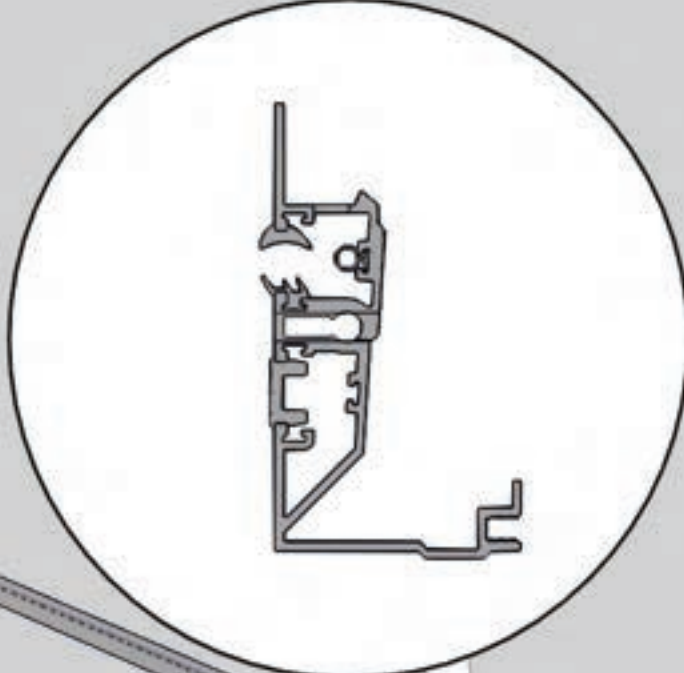

BACK FRAME ASSEMBLY

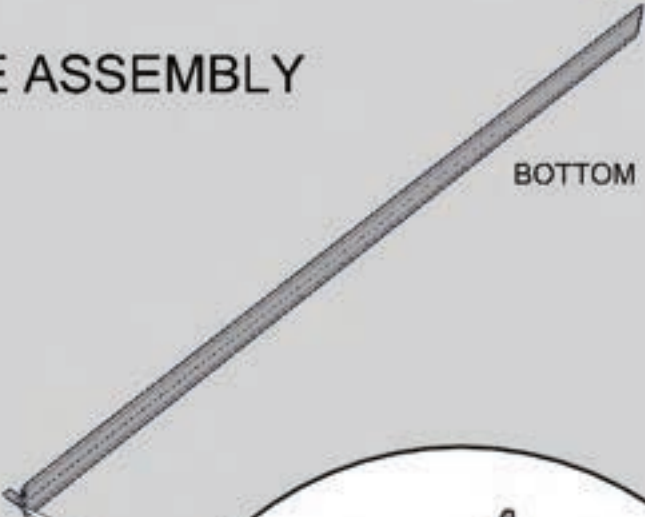
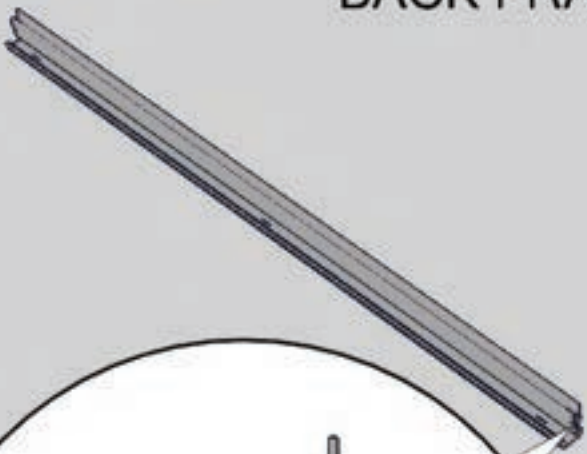

BOTTOM

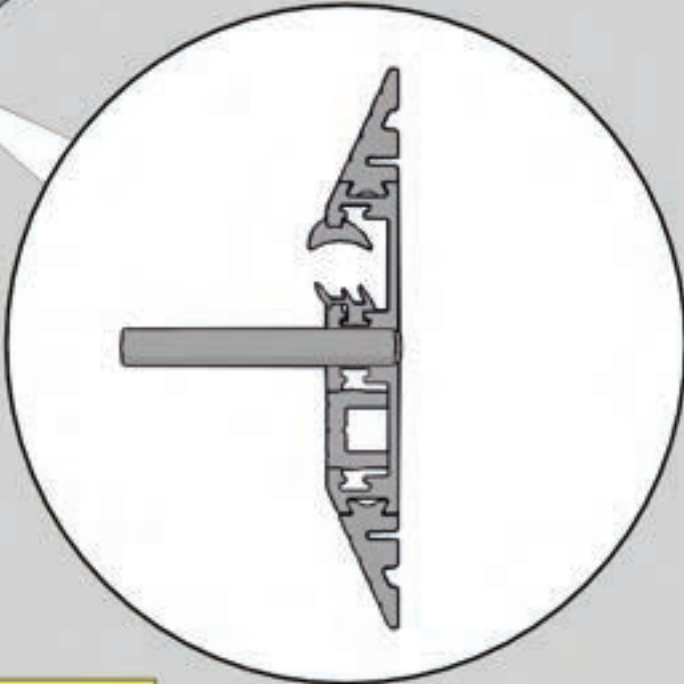
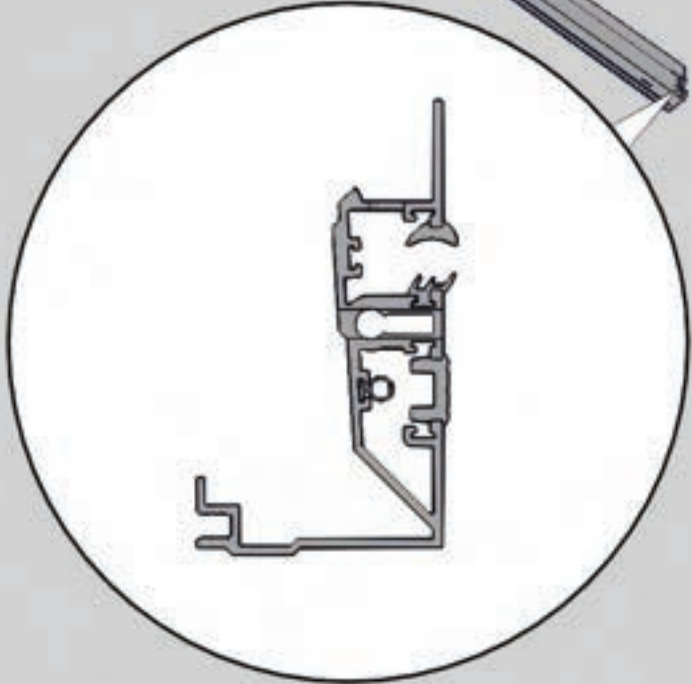

ONE PERSON MINIMUM

(SAME CONNECTION IN BOTH TOP CORNERS)

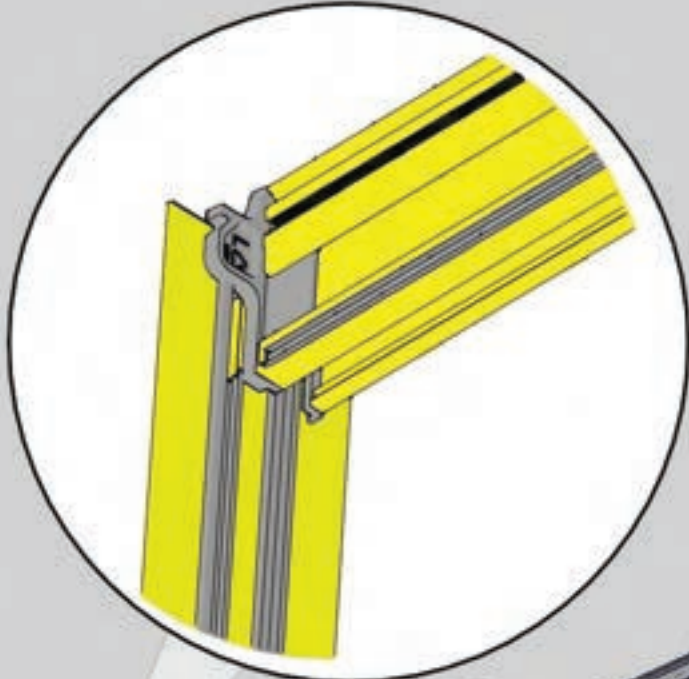

TOP

BACK FRAME ASSEMBLY

BOTTOM

(SAME CONNECTION IN BOTH BOTTOM CORNERS)

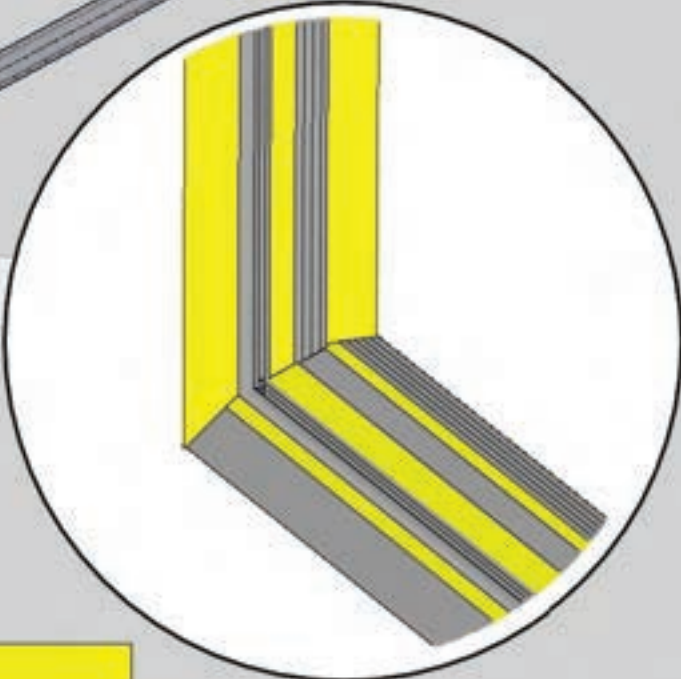

ONE PERSON MINIMUM

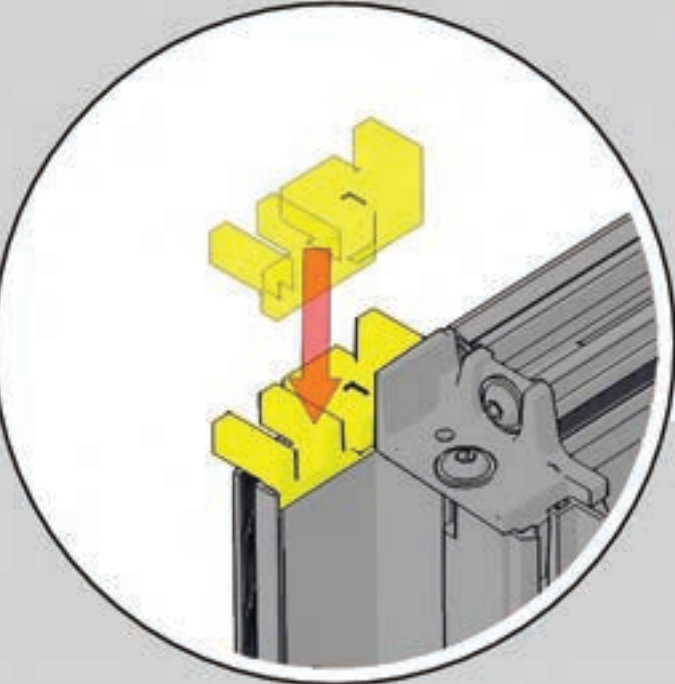
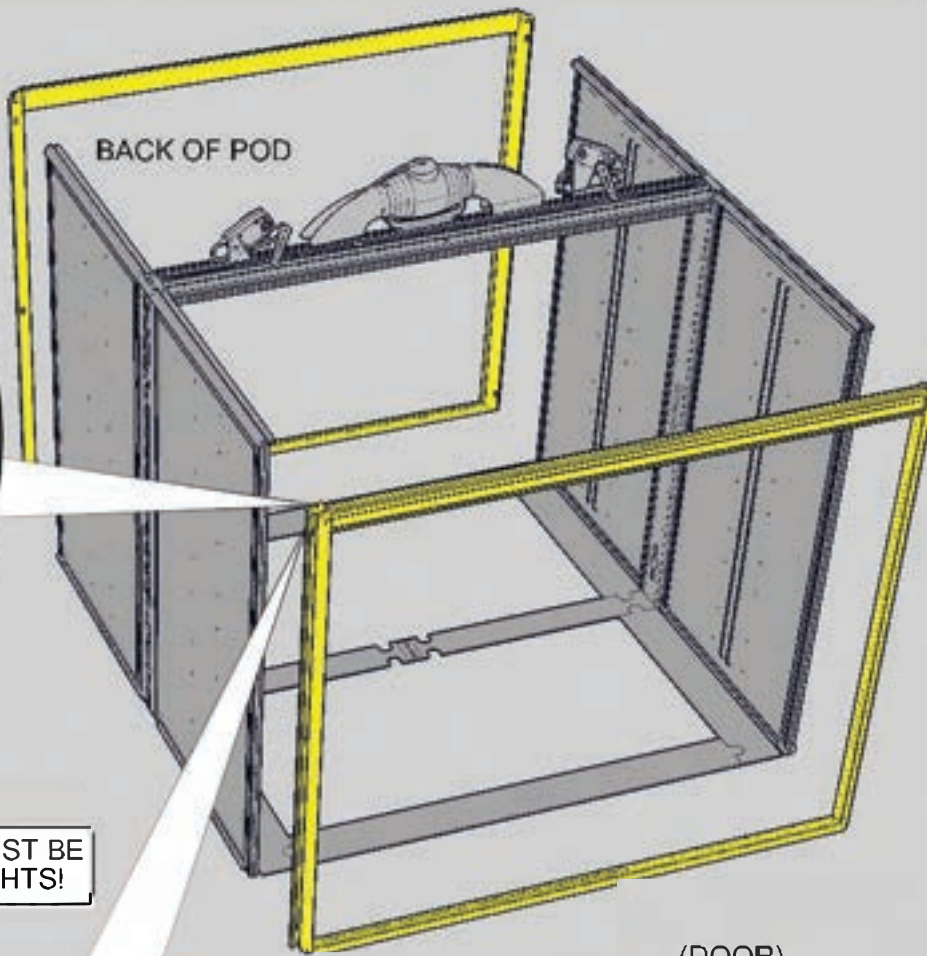

CAUTION:
 TOP OF GLASS FRAME UPRIGHTS MUST BE
 IN LINE WITH TOP OF SCREEN UPRIGHTS!



INSERT X4 CORNER
 BUNGS INTO TOP
 OF UPRIGHTS BEFORE
 ATTACHING TO SCREENS

1 OFFER FRAME UP TO SCREENS AND
 ATTACH AS SHOWN

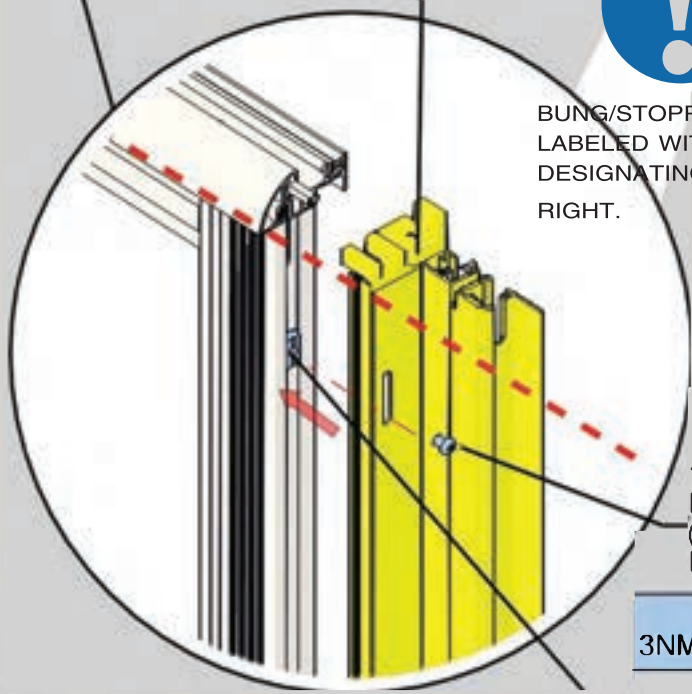

BUNG/STOPPER WILL BE
 LABELED WITH "L" OR "R"
 DESIGNATING LEFT AND
 RIGHT.

12 M6 X 8
 NO4 T-BAR
 (M6X12 FOR
 HAL FPODS!)

TORQUE
 3NM (2.21 FT-LBF)

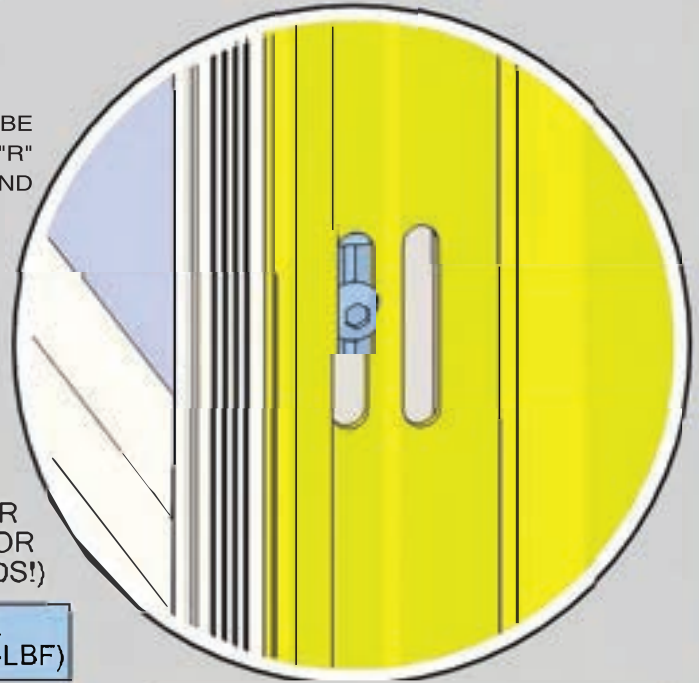

QTY 3 M6 ROLL IN T NUTS PER UPRIGHT. LOCATE THESE ON INDENTATION IN UPRIGHT.
 REPEAT 4 TIMES (LOCATE 3 AT THE END OF EACH OF THE 4 SCREENS)



TWO PERSONS MINIMUM

SEE THE PAGE 10.6-10.7

1

ROLL FIXING INTO EXTRUSION SECTION AS SHOWN

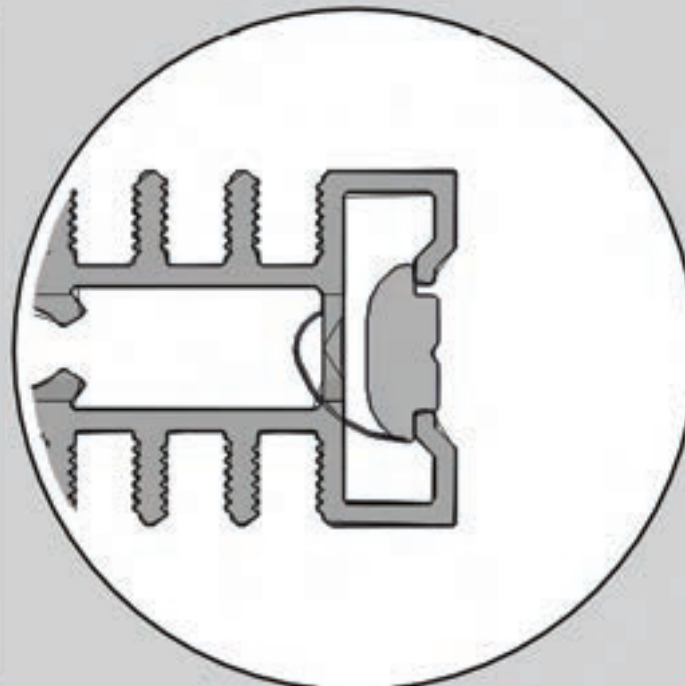
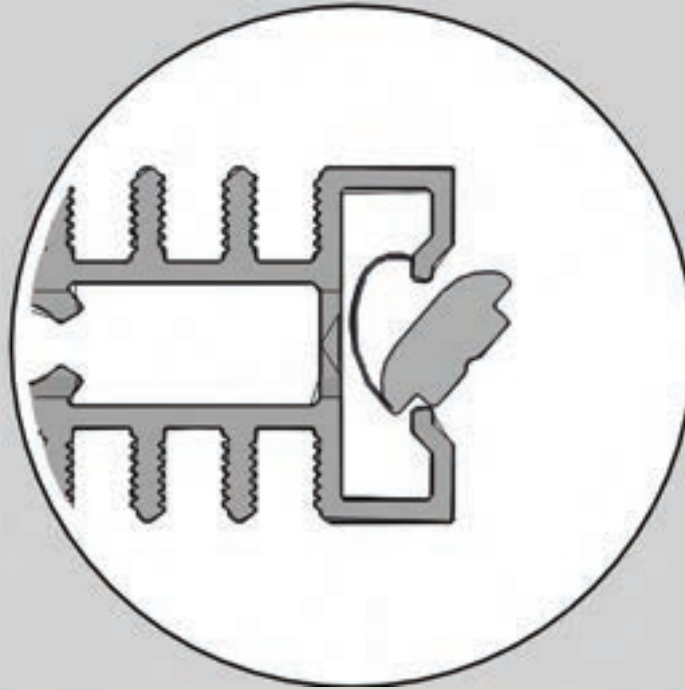

2

PUSH FIXING INTO PLACE AS SHOW. THE SPRING WILL HOLD THE FIXING IN PLACE



ONE PERSON MINIMUM

**SQUARE POD
GLASS FRAME ASSEMBLY
(WHEN FLOOR SPACE
IS LIMITED)**

1

LOCATE BOTTOM DOOR TRACKS ON FLOOR AS SHOWN (REPEAT SAME PROCESS FOR FRONT AND BACK FRAMES)

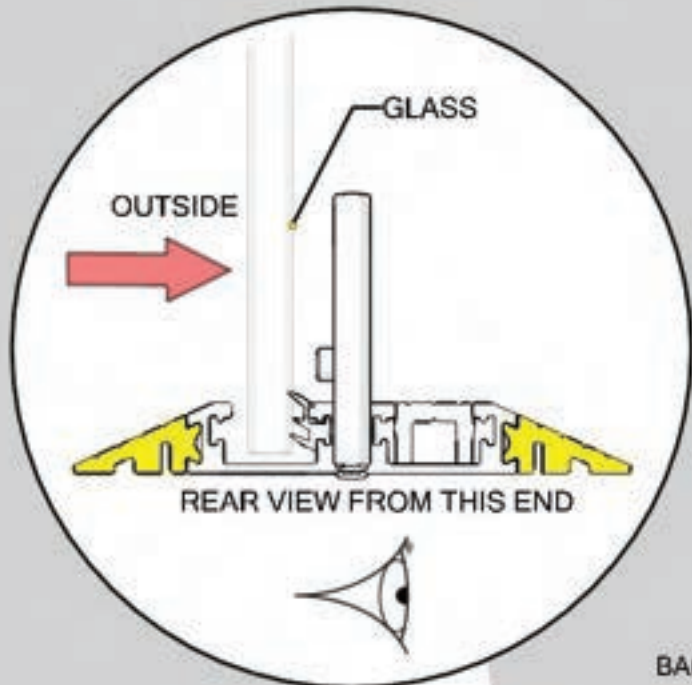

BACK OF POD

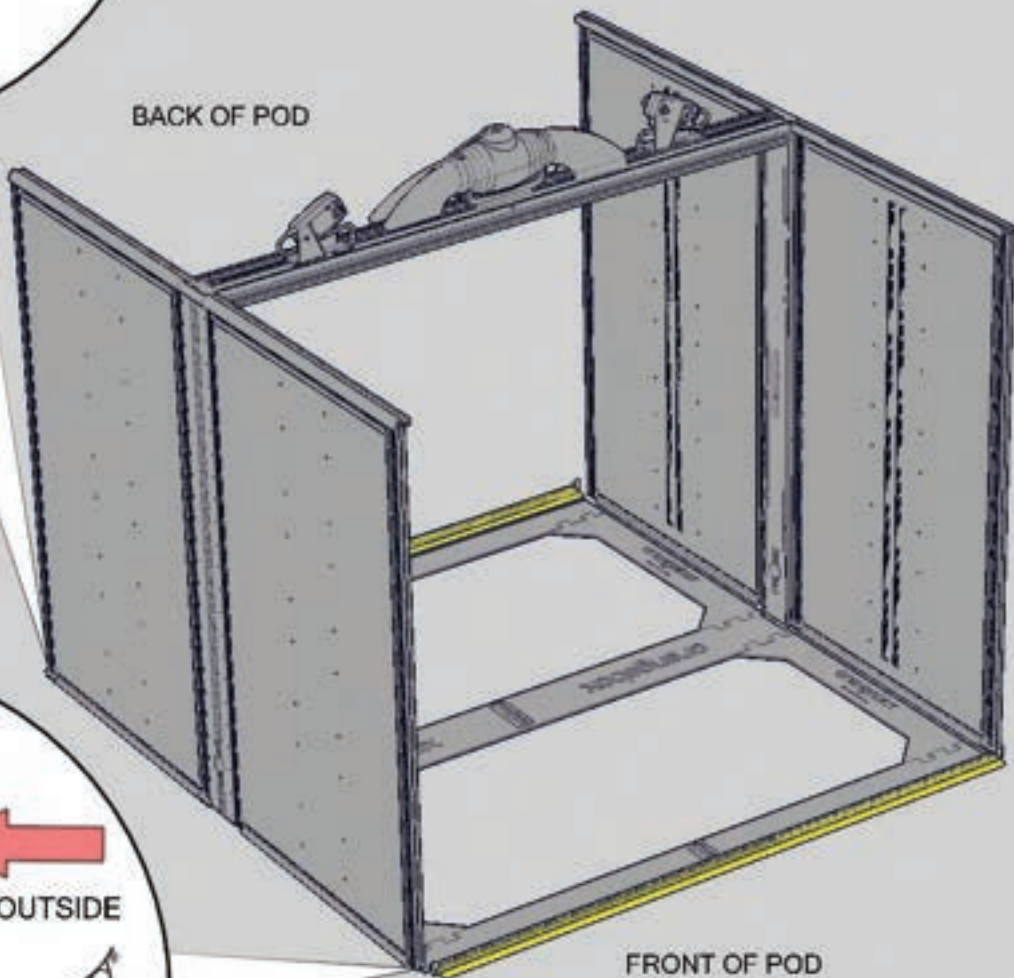

NOTE DIFFERENT CONFIGURATIONS OF SEALS

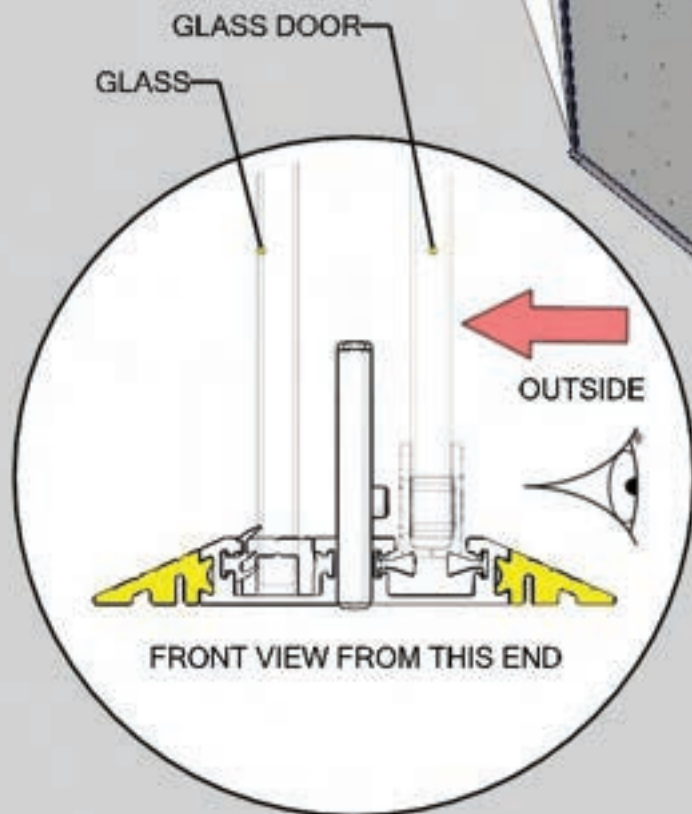

FRONT OF POD (DOOR)



ONE PERSON MINIMUM

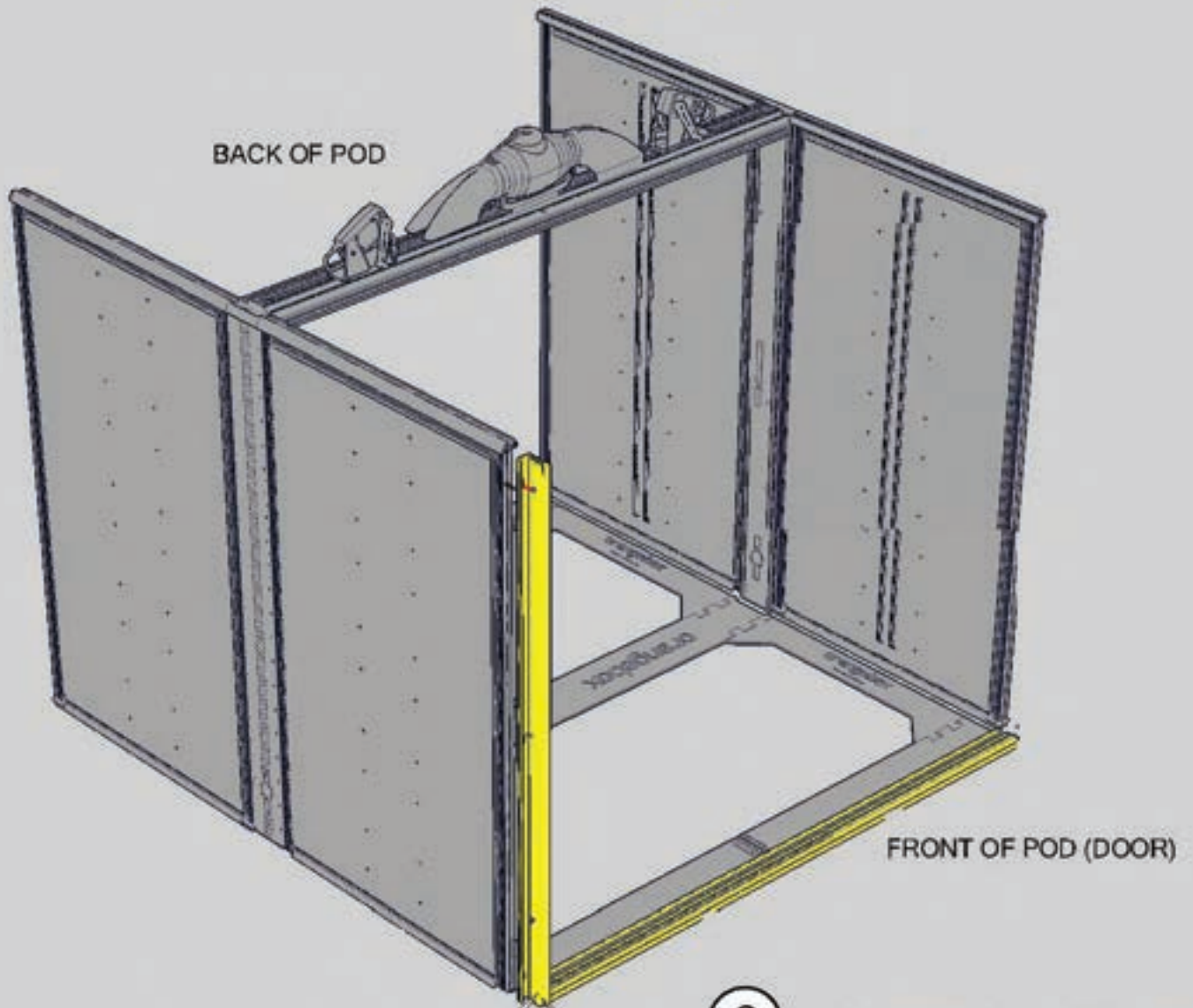

1 LOCATE UPRIGHTS OVER CASTING

2 LOCK UPRIGHT INTO POSITION USING GRUB SCREW

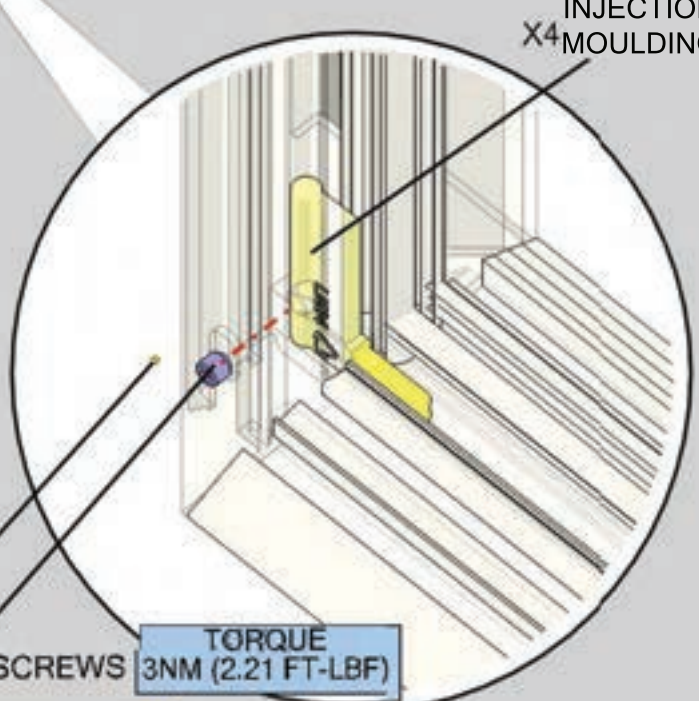
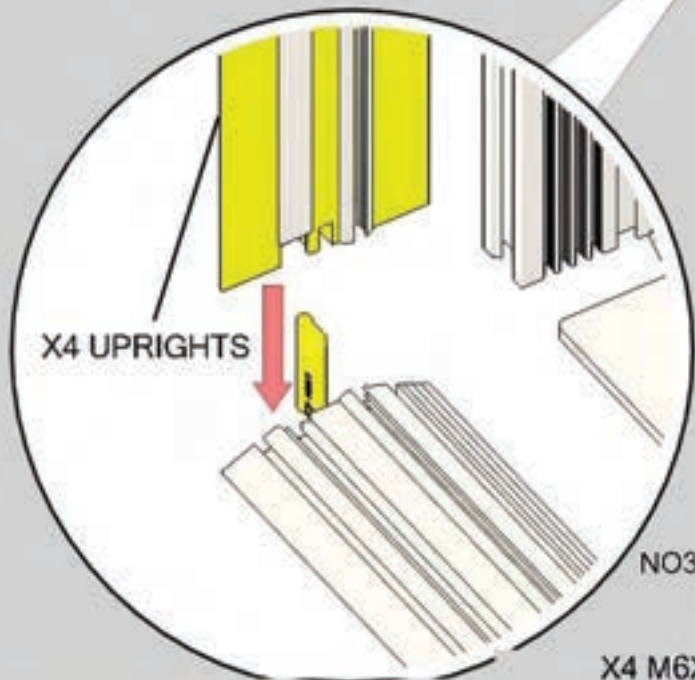

ONE PERSON MINIMUM

SEE PAGE 10.6

2 ATTACH UPRIGHTS ONTO THE SCREENS USING THE FIXINGS AS SHOWN

BACK OF POD



TOP OF GLASS FRAME UPRIGHTS MUST BE IN LINE WITH TOP OF SCREEN UPRIGHTS!

1 INSERT X4 CORNER BUNGS INTO TOP OF UPRIGHTS BEFORE ATTACHING TO SCREENS

FRONT OF POD (DOOR)

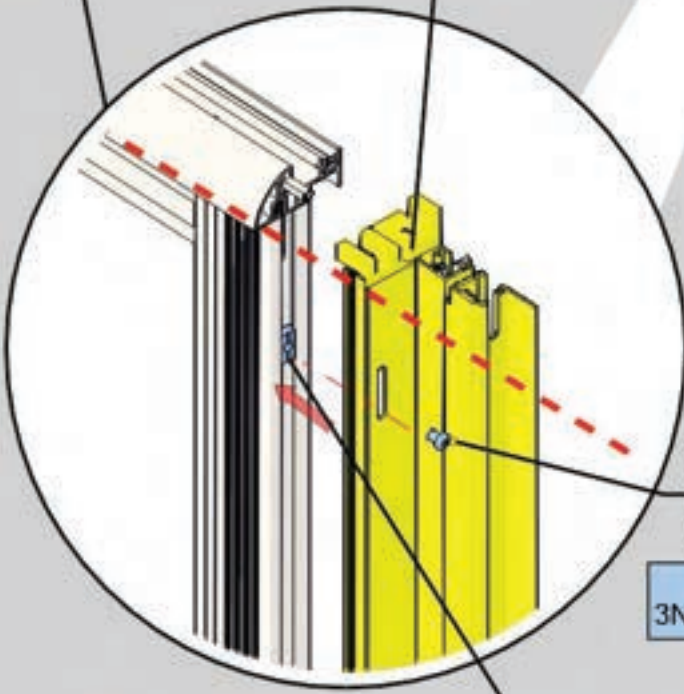

12 M6 X 8
NO4 T-BAR
(M6 X 12 FOR
HALF PODS!)

TORQUE
3NM (2.21 FT-LBF)

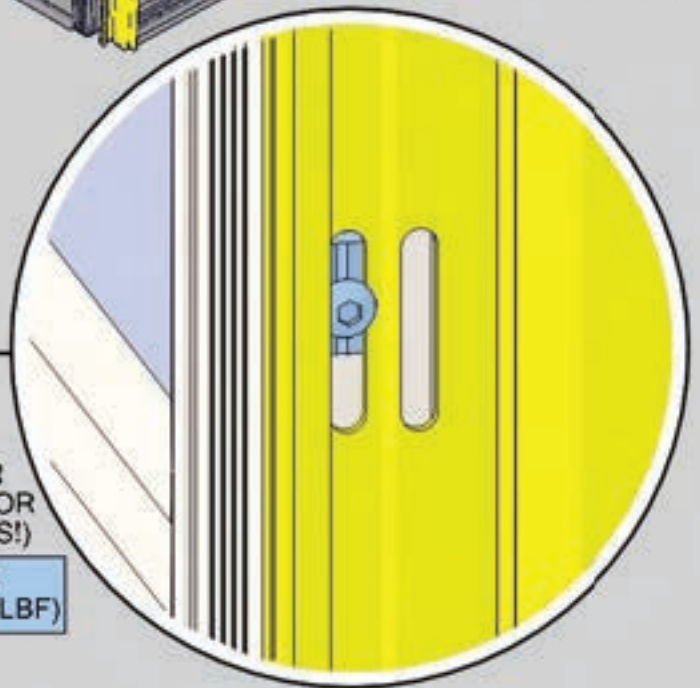

QTY 3 M6 ROLL IN T NUTS. LOCATE THESE ON INDENTATION IN UPRIGHT. REPEAT 4 TIMES (LOCATE 3 AT THE END OF EACH OF THE 4 SCREENS)



ONE PERSON MINIMUM

SEE PAGE 10.6 - 10.7

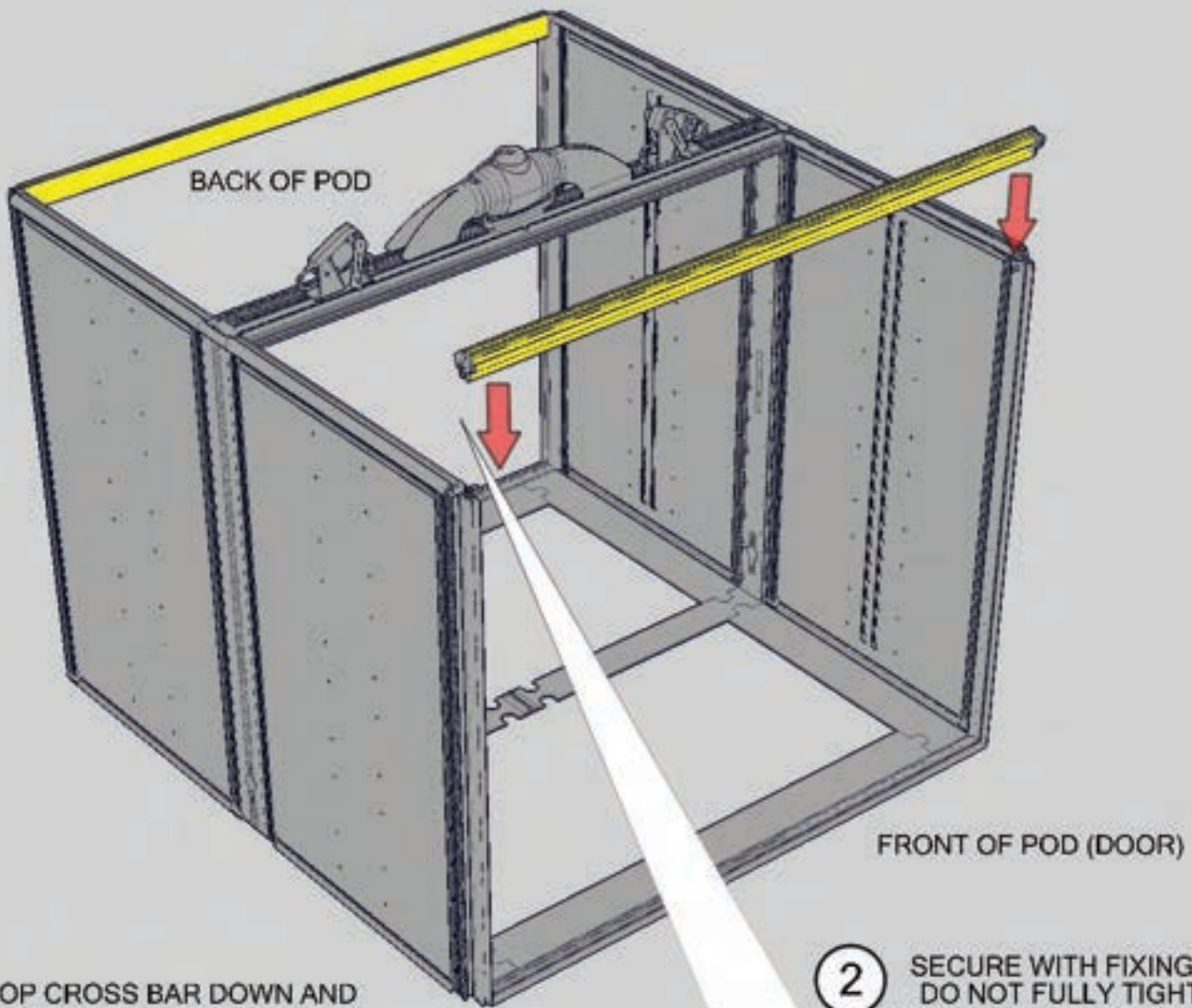

1 DROP CROSS BAR DOWN AND ALIGN THE TWO HIGHLIGHTED CHANNELS TO AID LOCATION

2 SECURE WITH FIXING BUT DO NOT FULLY TIGHTEN. CROSSBAR CAN BE ADJUSTED IN HEIGHT WHEN INSTALLING GLASS. (THE BACK TOP CROSSBAR CAN BE FULLY TIGHTENED)

M8X25 NO5

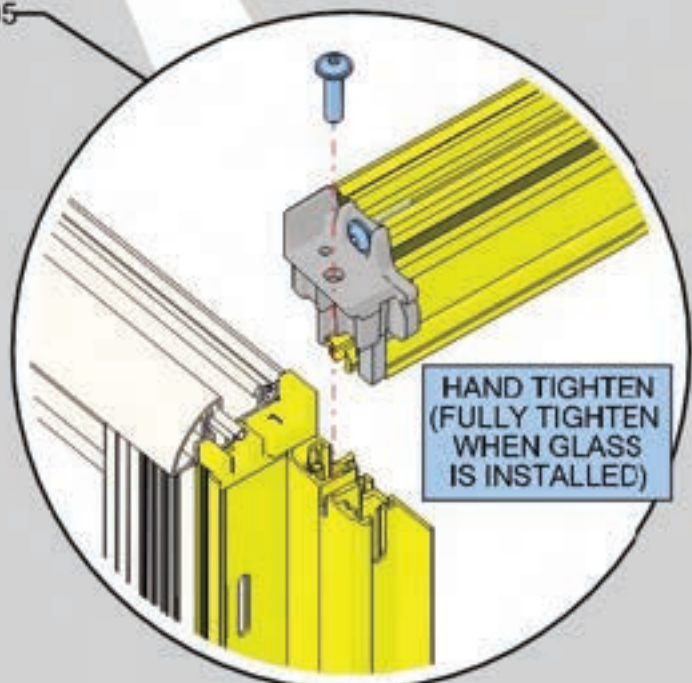
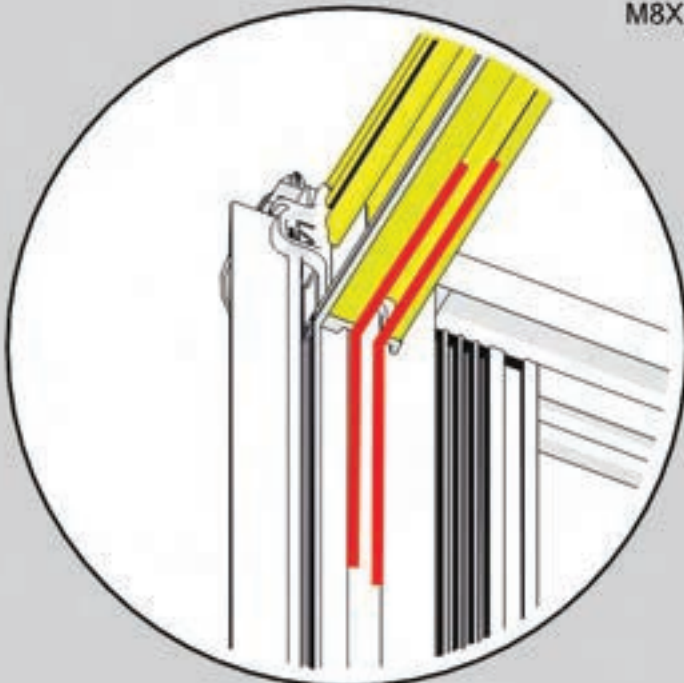

TWO PERSONS MINIMUM

Connect the rear glass frame to the hoop on the back of an Air 23 using the contents from box labeled "half pod kit"

Hoop & attached fan motor

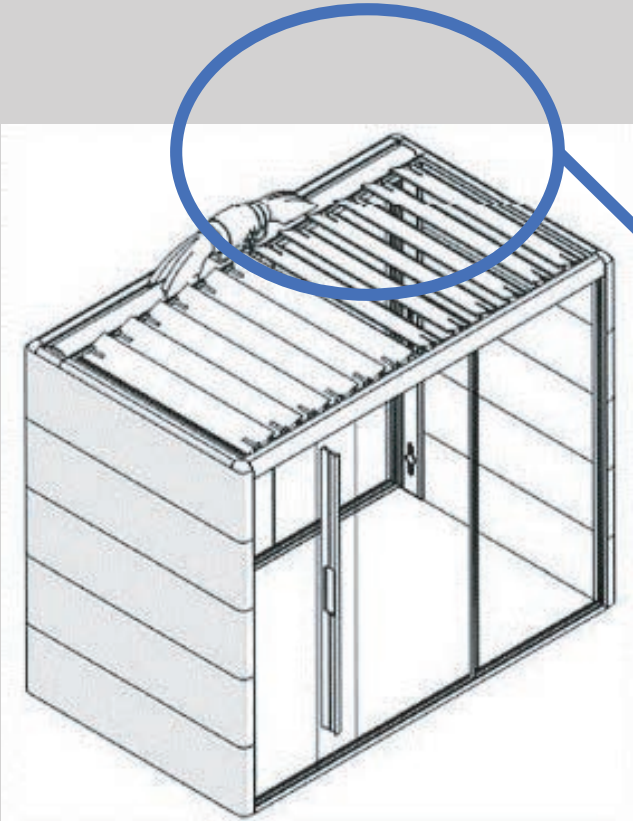

Half Pod kit contents:

- longer bolts
- special corner caps
- Hoop-to-door track seal (not pictured)

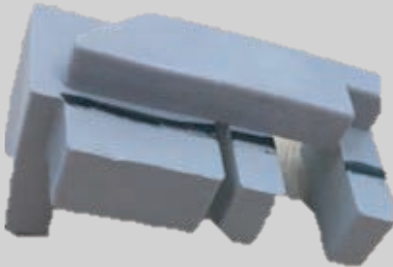

Other Modifications: RH and LH corner bungs need to be modified for AIR-23 version. Cut off extensions at the black line shown here. Black line is on drawing only, not on bungs.

Ensure top of frame upright is under the bottom of the hoop



Bottom of hoop

Frame upright

orangebox

air³

Assembly sequence

Opening roofs

section



* NO UNAUTHORIZED PERSONEL PERMITTED TO PARTICIPATE IN ASSEMBLY (ORANGEBOX CERTIFIED PERSONNEL ONLY)

* APPROPRIATE PPE MUST BE WORN AT ALL TIMES DURING ASSEMBLY OF ORANGEBOX PRODUCTS

* PART ASSEMBLED PODS MAY NOT BE LEFT UNATTENDED UNLESS STRUCTURALLY SOUND

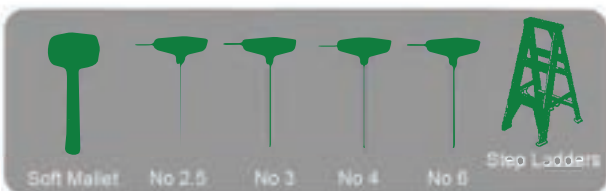

Aluminum Roofs are fixed as standard and link age kits are added to make them into a opening roof.

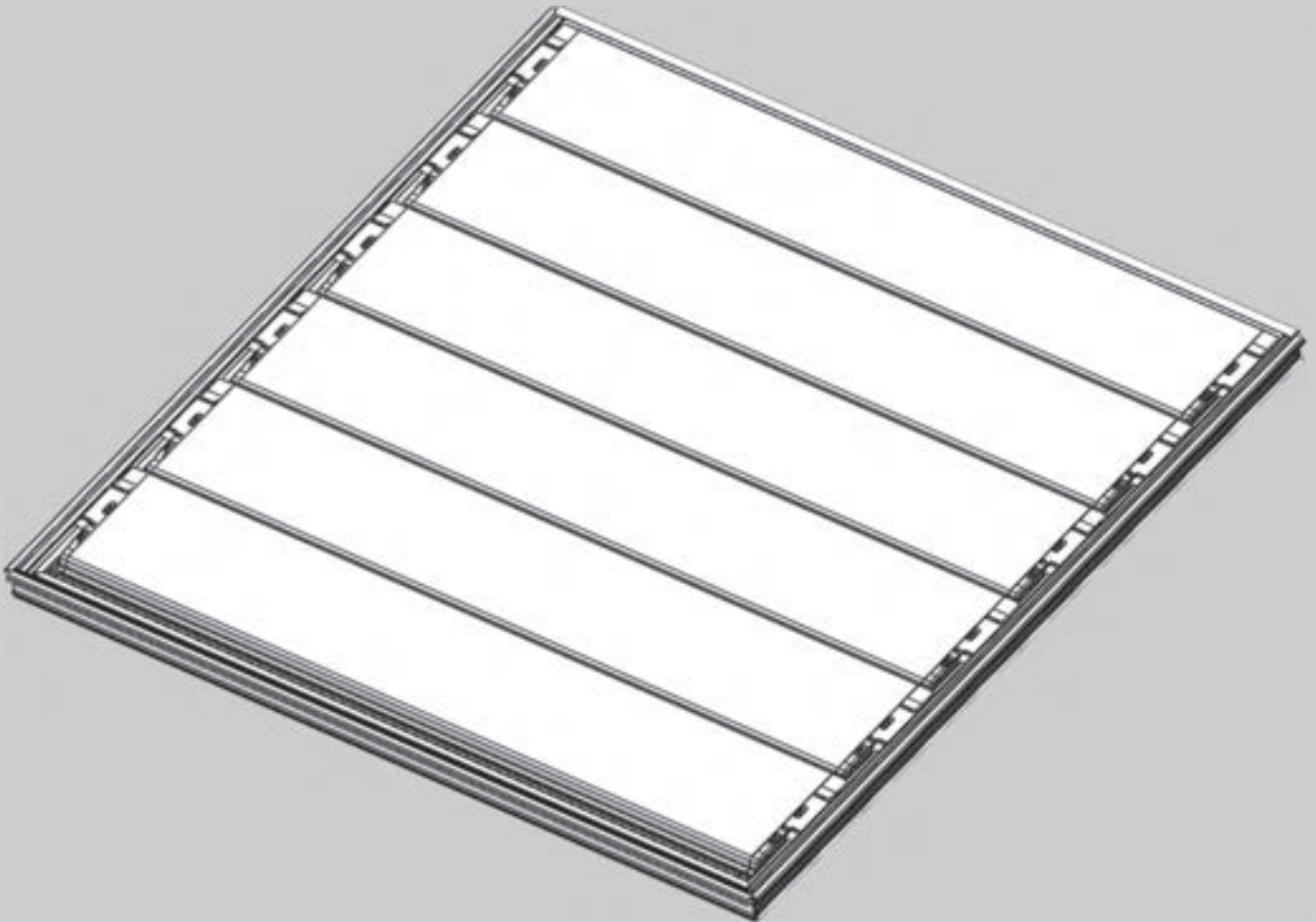

There are locking strips that run down either side of the roof, these keep the blades locked down during transport, and keep it shut if the panel is used as a fixed roof.

But need to be removed if it's a opening roof.

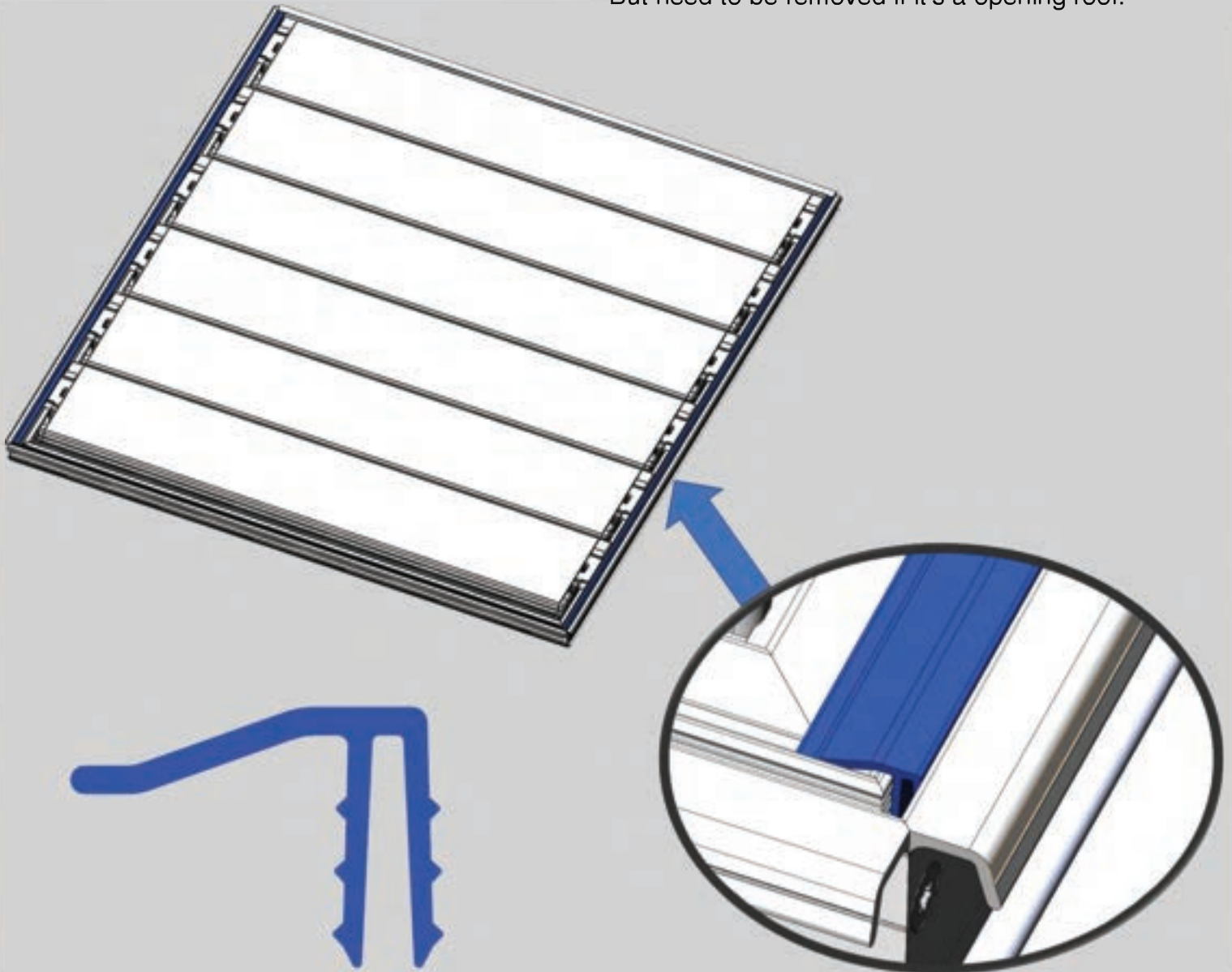

There will also be a joining strip in every box, this is used between the panels to ensure no light come in-between the roof panels.

There will always be more strips than what are required.

This is the last piece to be fitted.

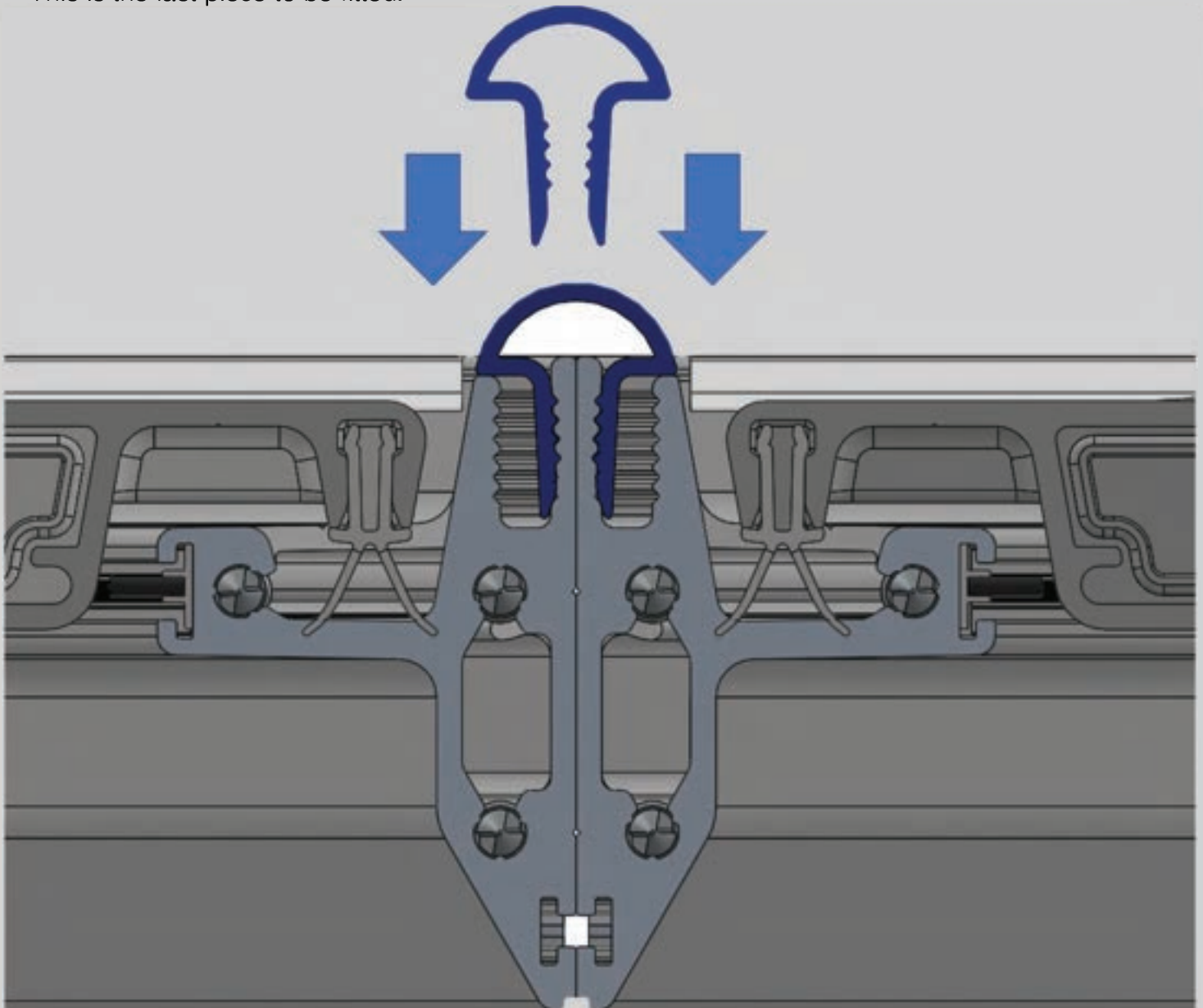

Linkage kits need to be fixed to the roof panels to make them into opening roofs, there are LH/ RH assemblies that are boxed together, plus an intermediate kit that is used on the AIR-27 and AIR-29.

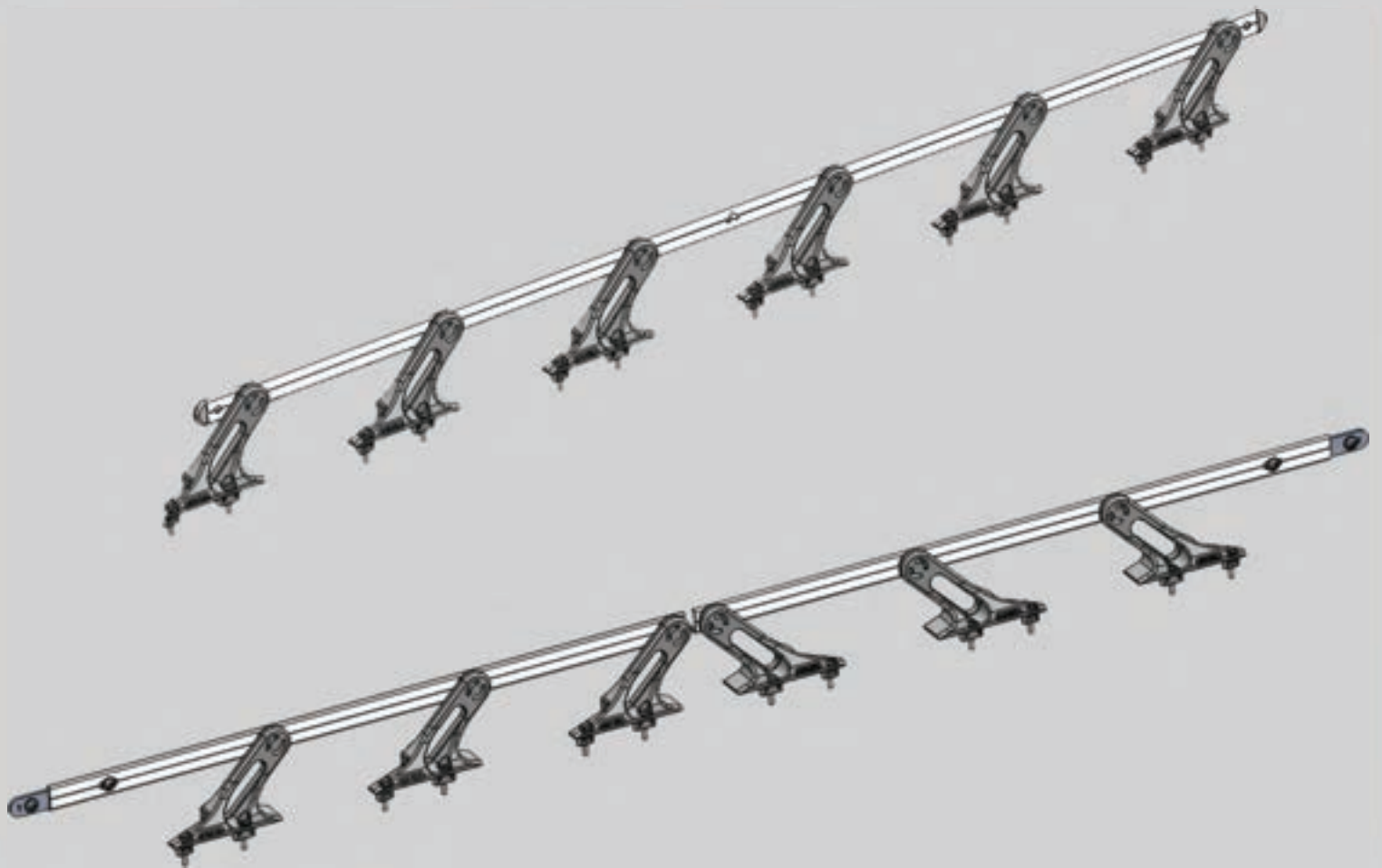

The linkage kits need to be assembled to the roof so that the thickest part of the linkage bar is on the bottom, also there is a "V" shape halfway down the bar, this should be pointing up.

This is critical on the AIR-29 when the middle roofs are connected to the outer roofs.

It wouldn't affect the AIR-23/25/27.

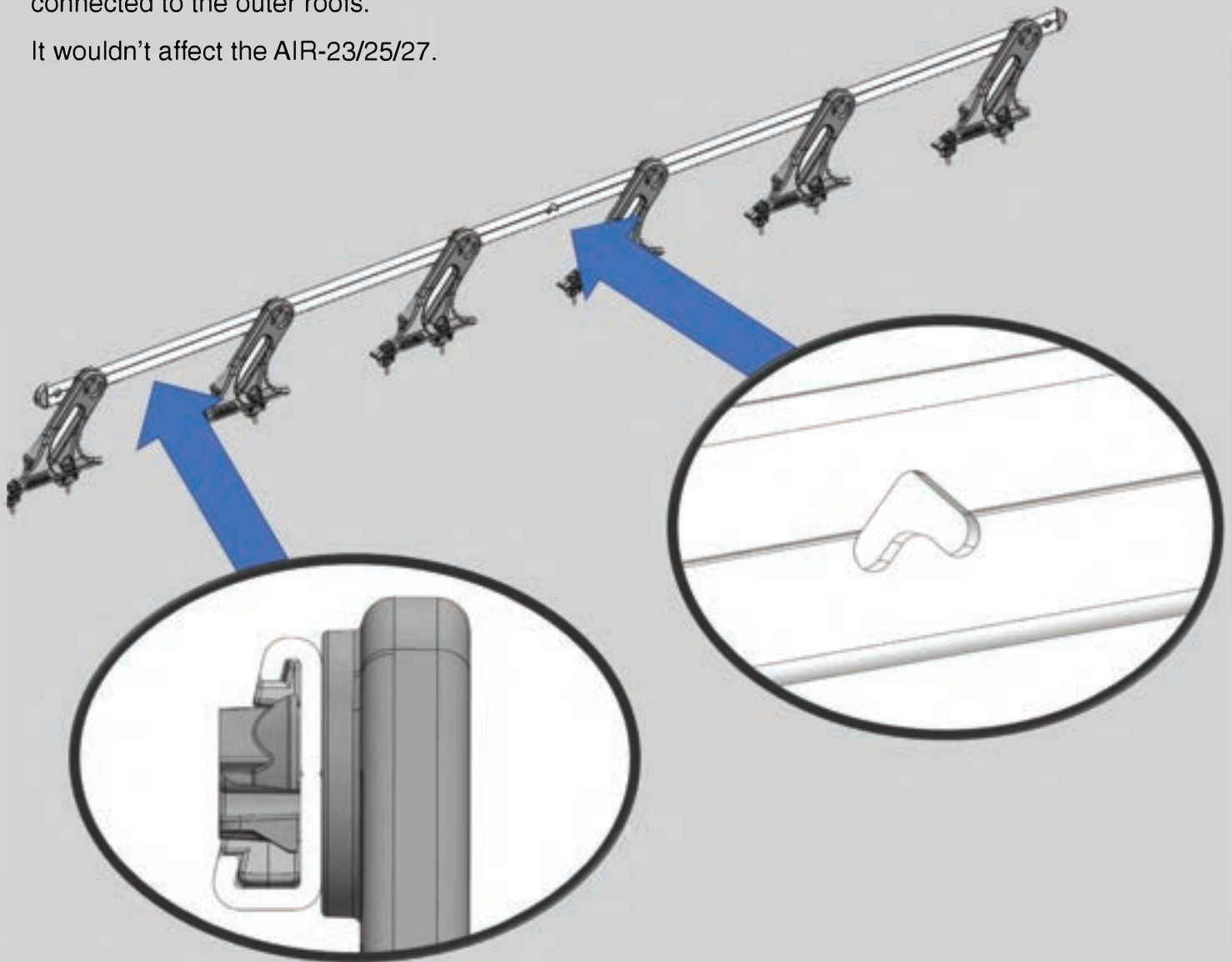

The linkage kits need to be assembled to the roof panels with the supplied screws, there are 12 screws in each bag (enough for the 1 panel).

Both the linkage kits and the roof blades are identified with left or right markings.

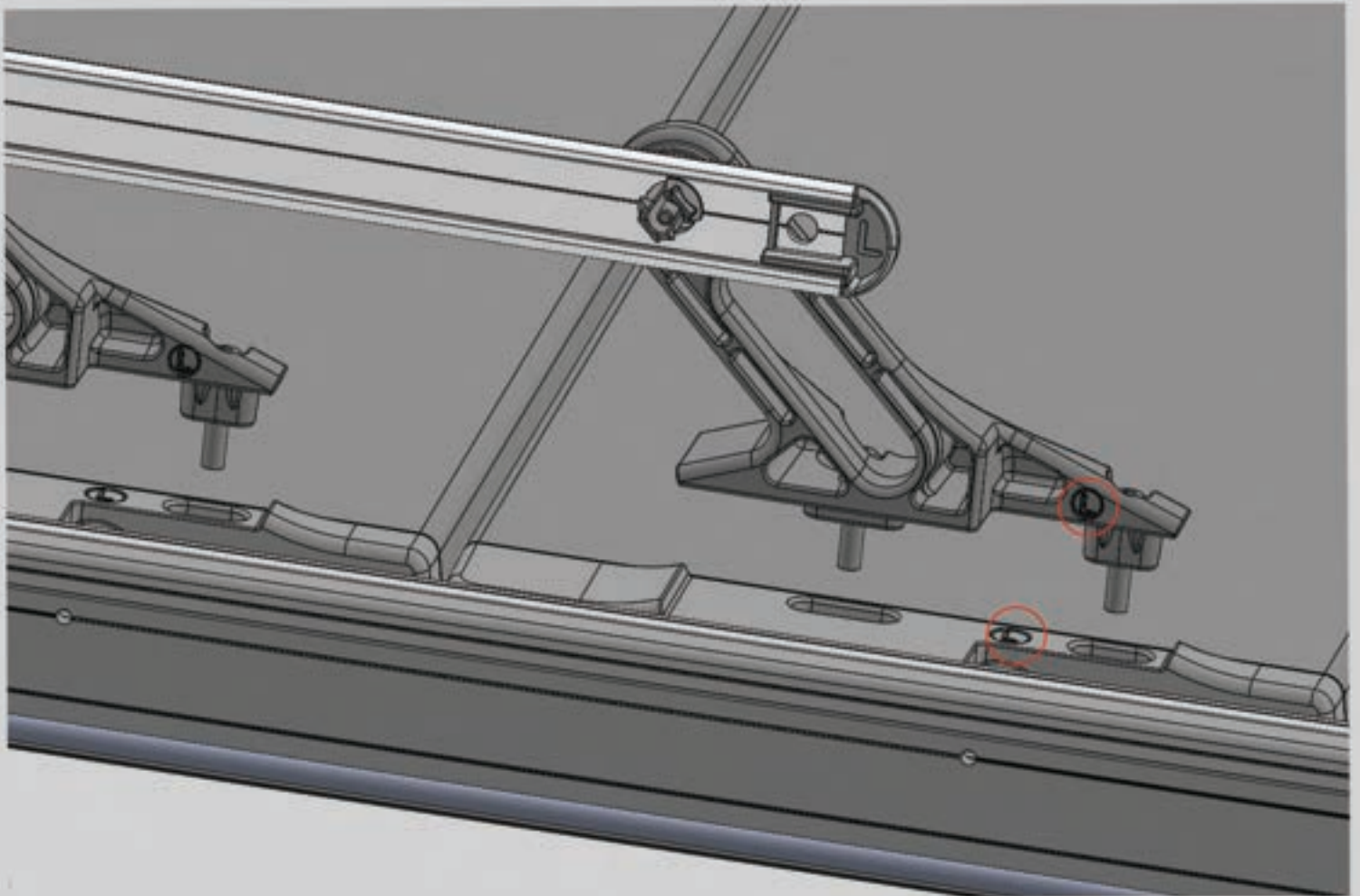

If the roof assemblies become tight to fit the plastic strip that runs down the side of the screens can be removed to free up some of the tolerance, this is more likely on an AIR-29 where the pod is 3 panels wide.

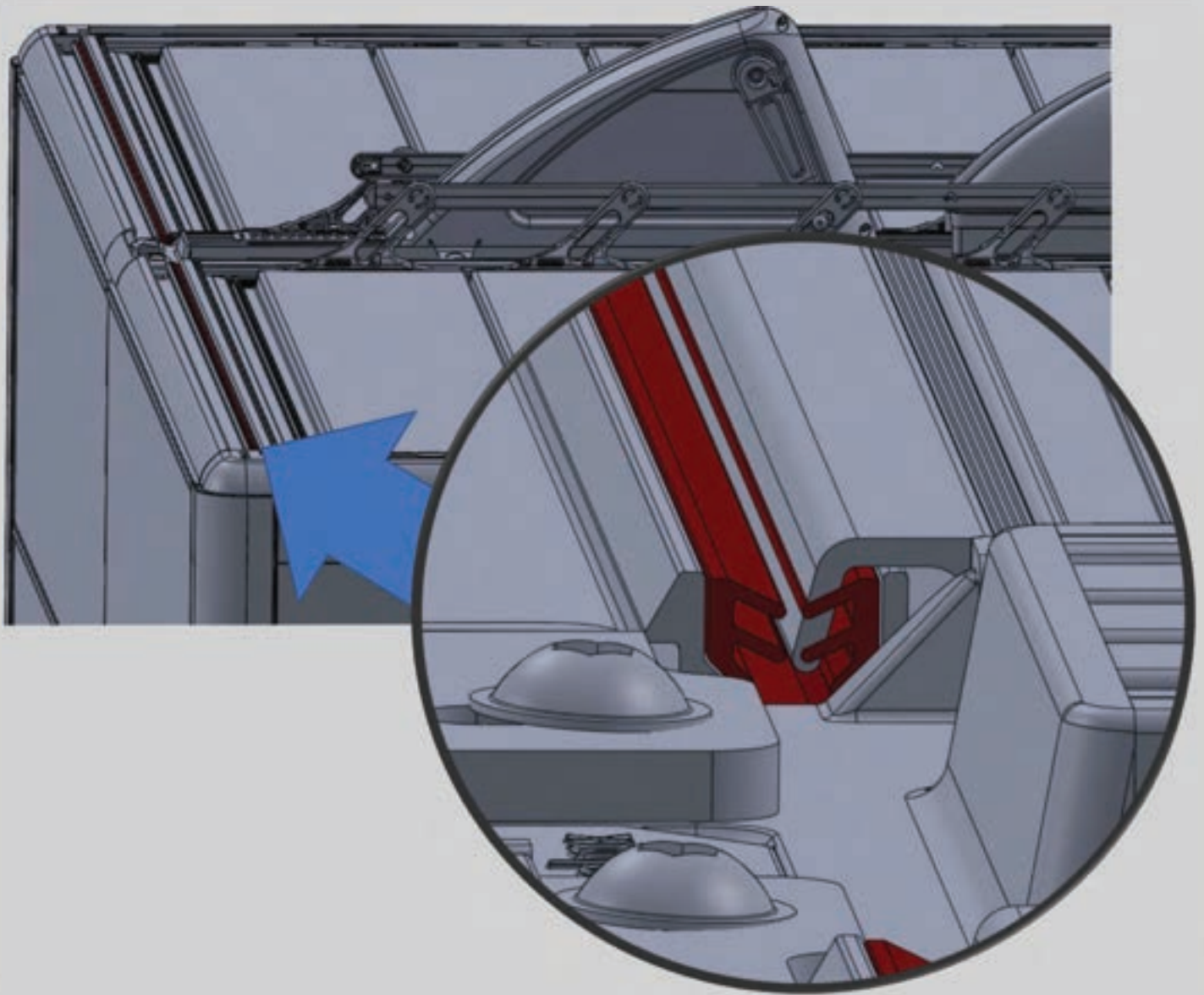

When installing the production office pod the installers found it easier to fit one roof panel, then fit the middle and outer panel at the same time angling them in together as the fit is quite tight.

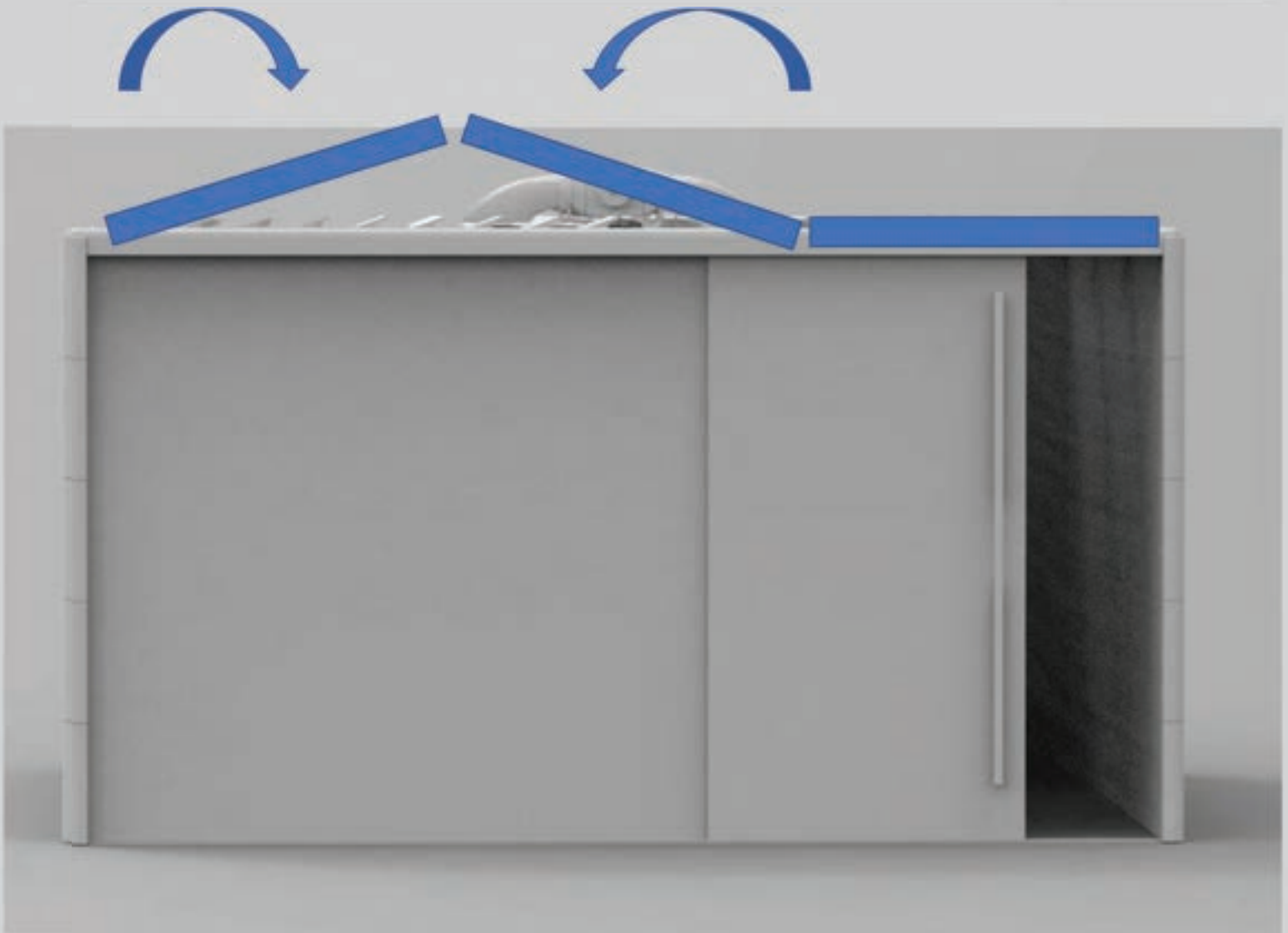

THREE PERSONS MINIMUM

All pods include brackets to lock down the aluminum roof.

Most pods include four (4) pilot holes in the hoop, however in some cases pilot holes may not be available.

If pilot holes are not available, the bracket cannot be fitted and should be left off.

 Using a drill on the aluminum is never advisable.

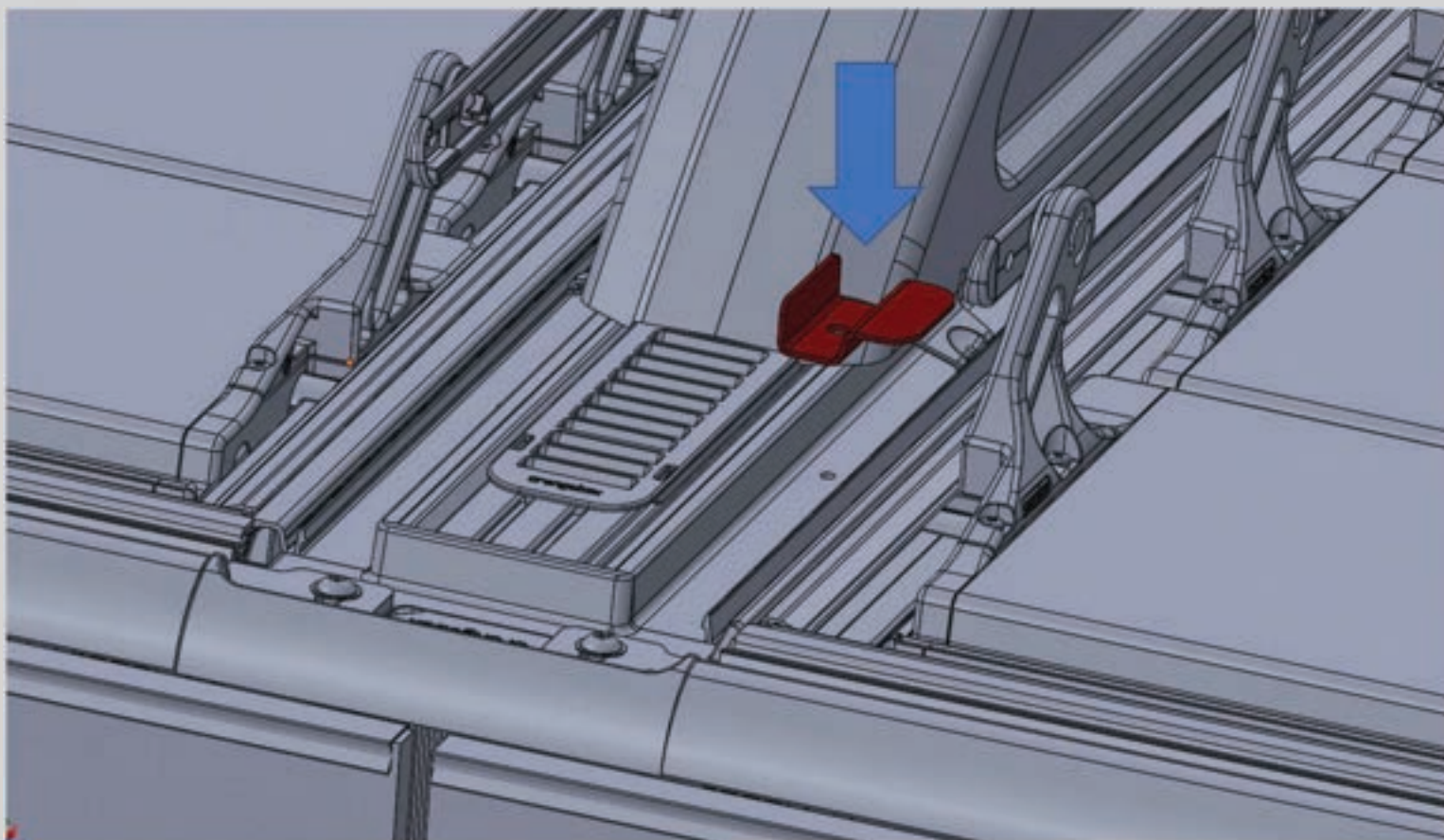

Aluminum Roof Panels

Configurations with Part Numbers

For the Fixed Roof Pods the Aluminium Roof Assemblies are used on their own.

Part Numbers are as follows:

AIRO-GA-050 STANDARD FIXED ROOF

AIRO-GA-051 HOOP TO HOOP FIXED ROOF

AIRO-GA-052 INTERMEDIATE STANDARD FIXED ROOF

AIRO-GA-053 INTERMEDIATE HOOP TO HOOP FIXED
ROOF

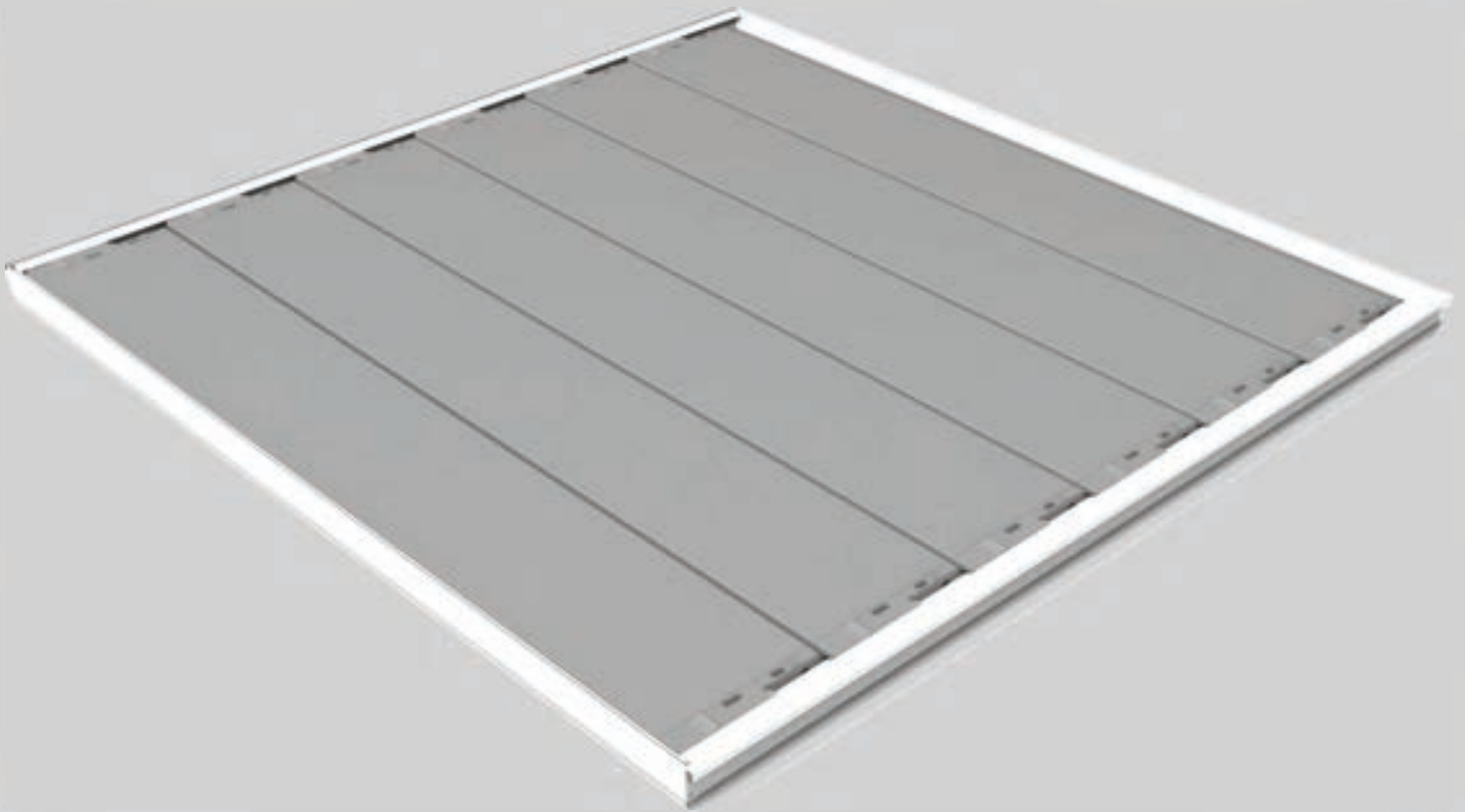

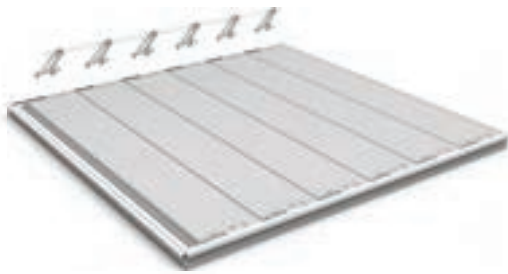

Linkage Assemblies are then added to the roof Assemblies prior to being fitted to the Pod.



AIRO-GA-029 contains both LH and RH linkages used on AIR-23/25/27/29.



AIRO-GA-027 used only down the middle roofs on an AIR-29.

AIR-23

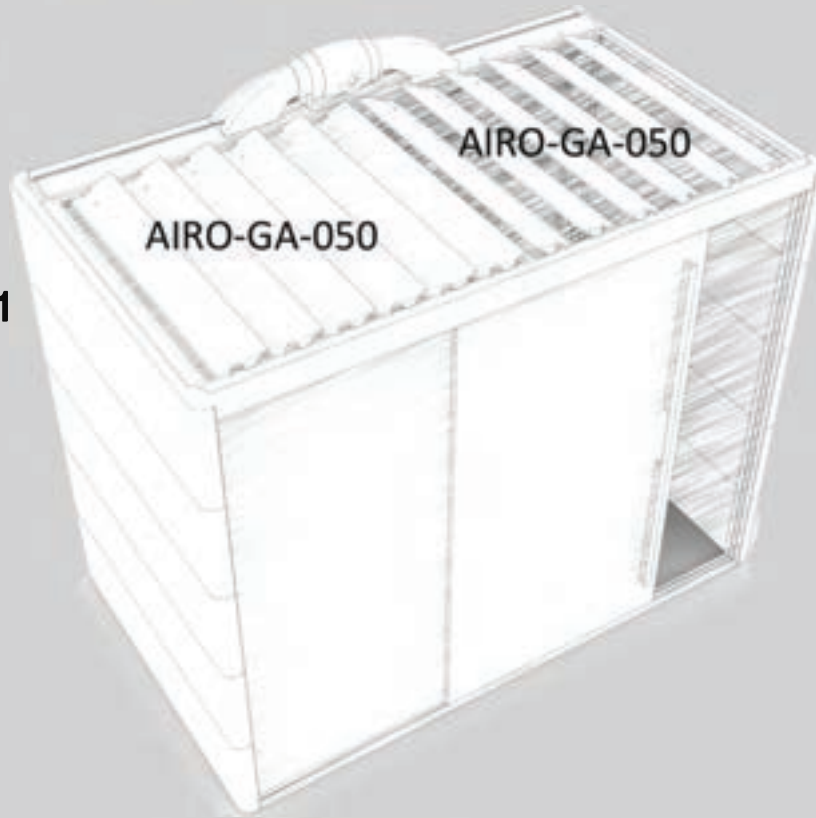

AIRO-GA-029 x1

AIR-25

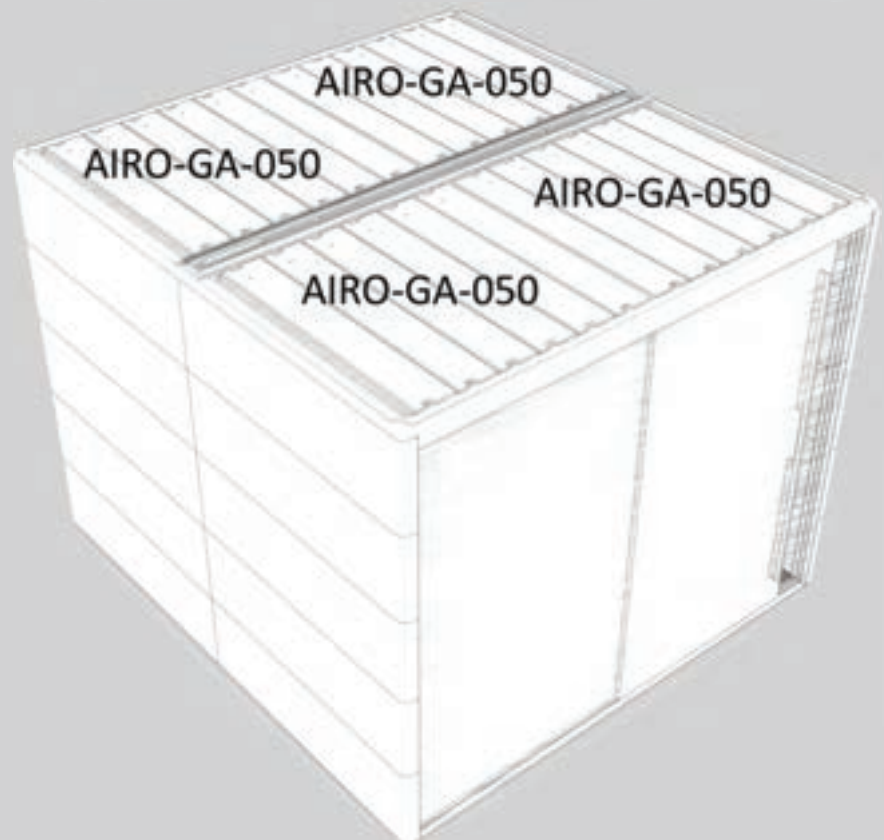

AIRO-GA-029 x2

AIR-27

AIRO-GA-029 x3

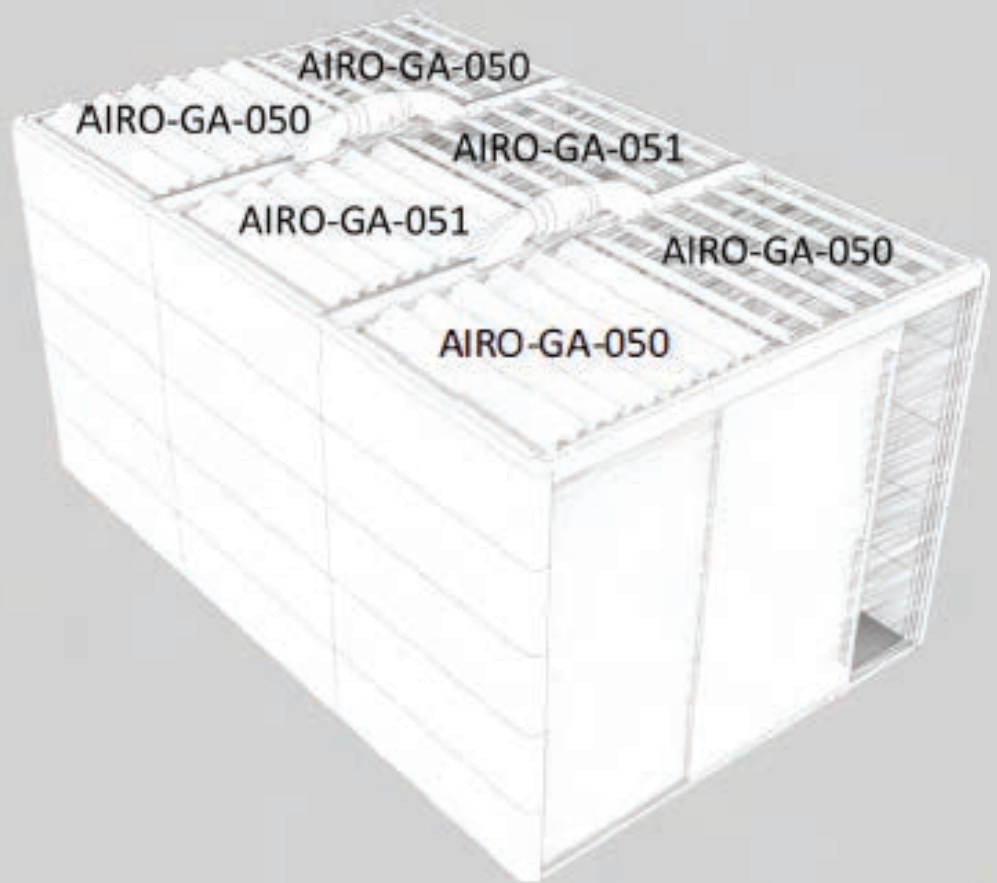

AIR-29

AIRO-GA-029 x3
AIRO-GA-027 x3

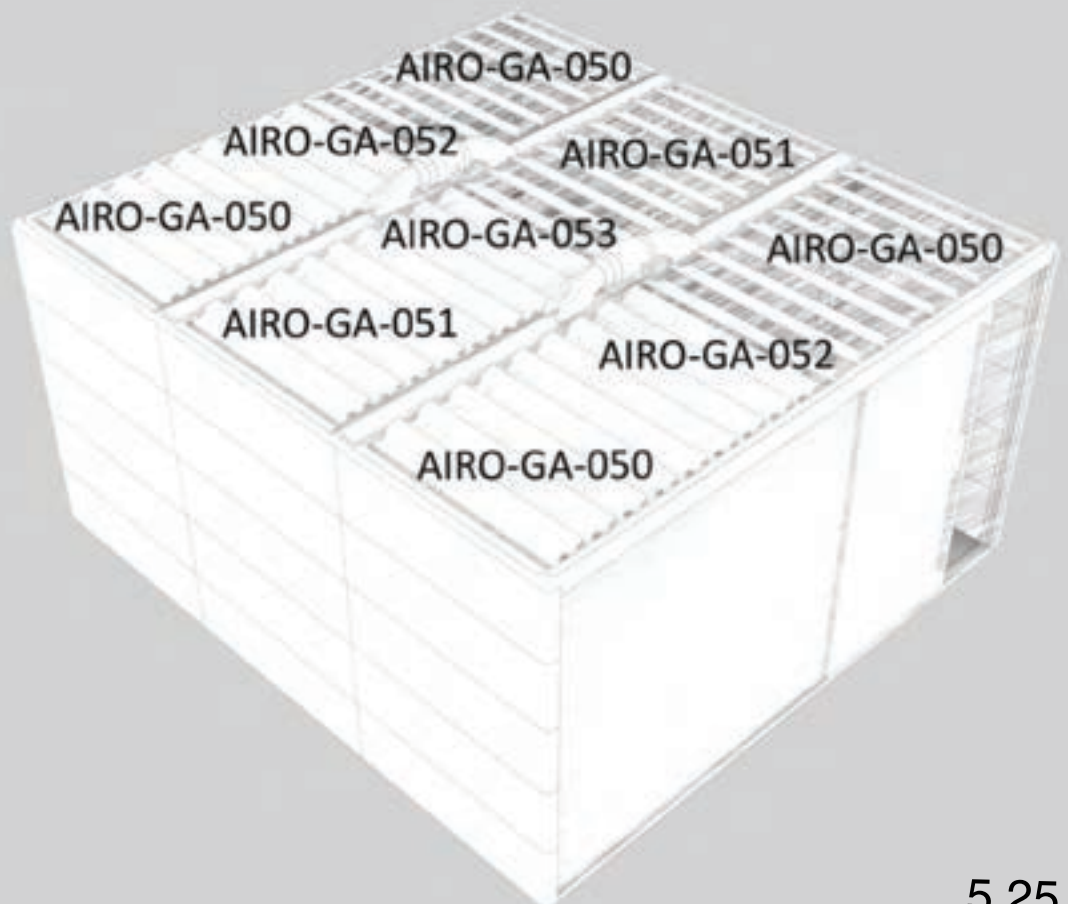

Opening Roofs - Assembly sequence

1

LOCATE THE COWLS OVER THE BELIMOS AND SNAP INTO THE EXTRUSION

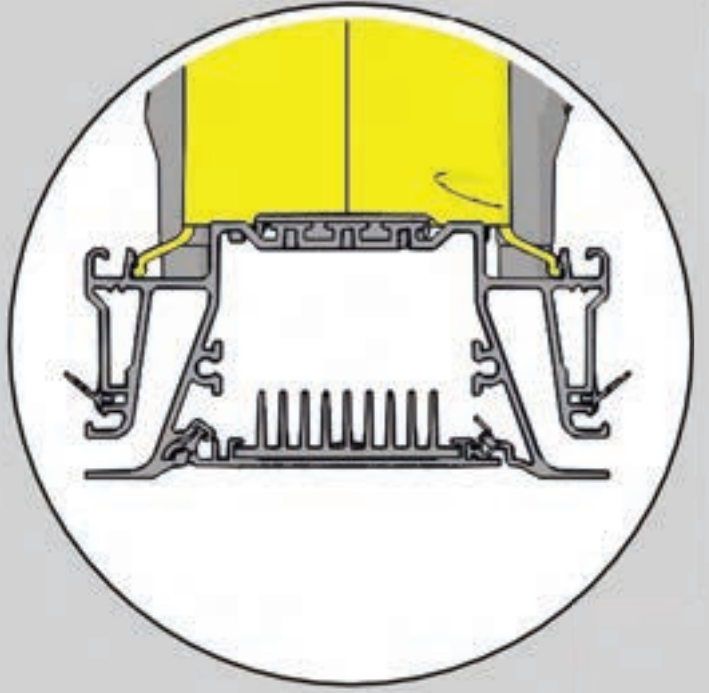
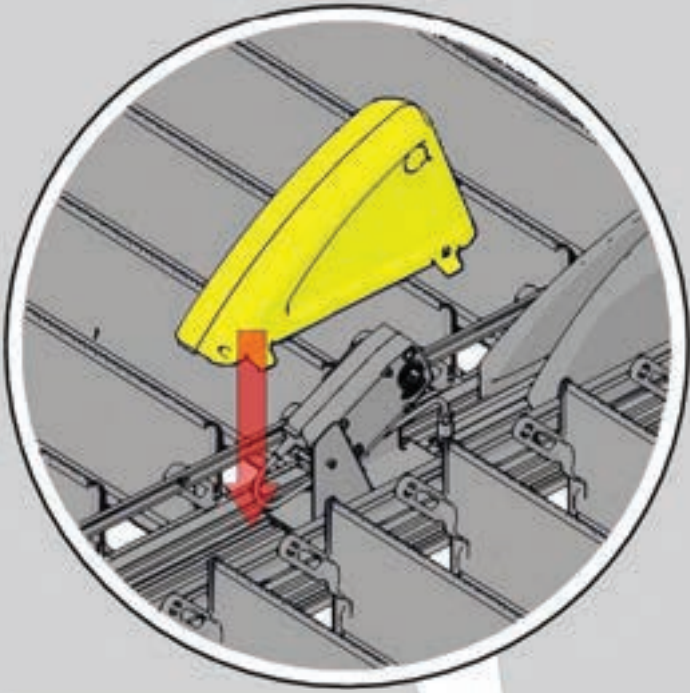

BACK OF POD

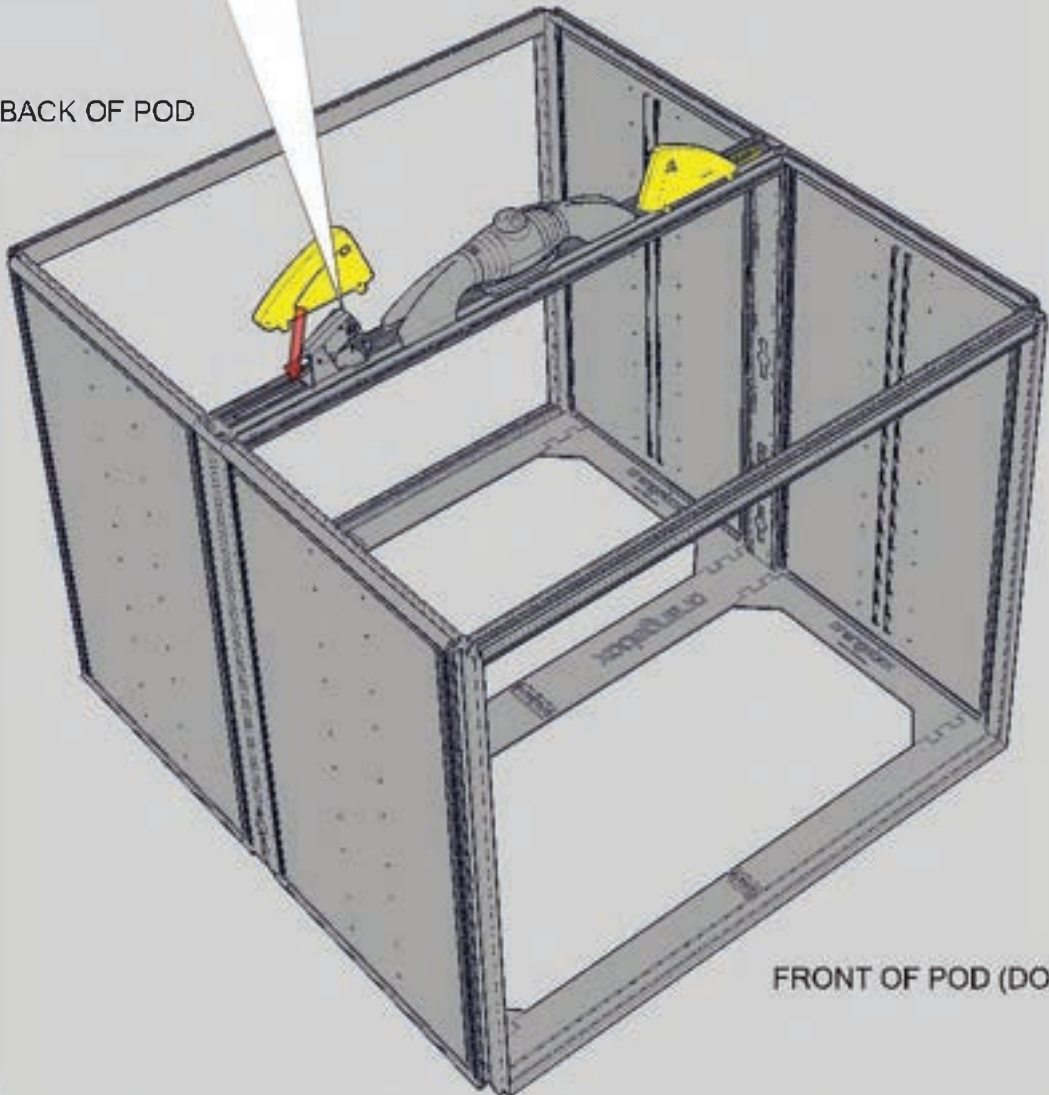

FRONT OF POD (DOOR)



ONE PERSON MINIMUM

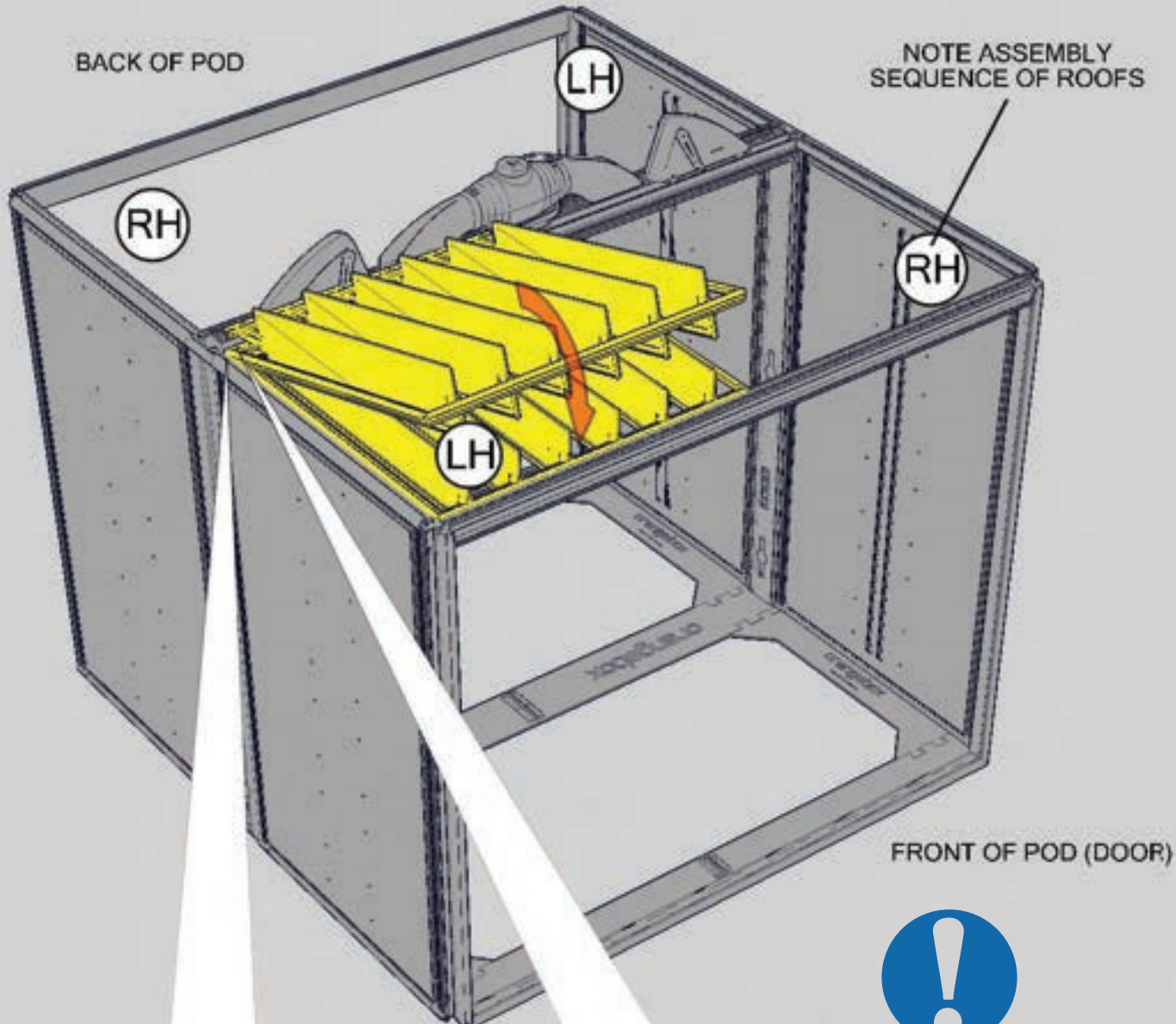

ROOF MUST LOCATE HALF WAY OVER LEG OF CASTING AS SHOWN APPROX 3MM (1/8")

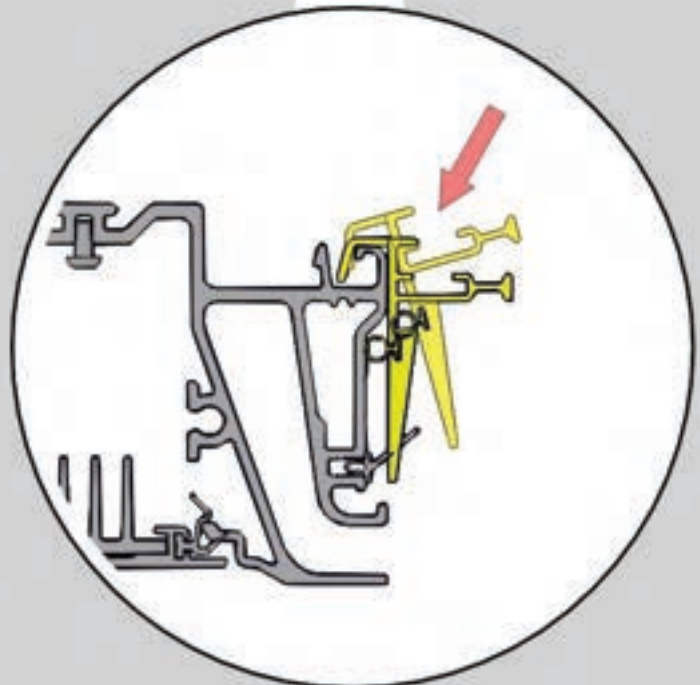

PROFILE VIEW ALONG HOOP

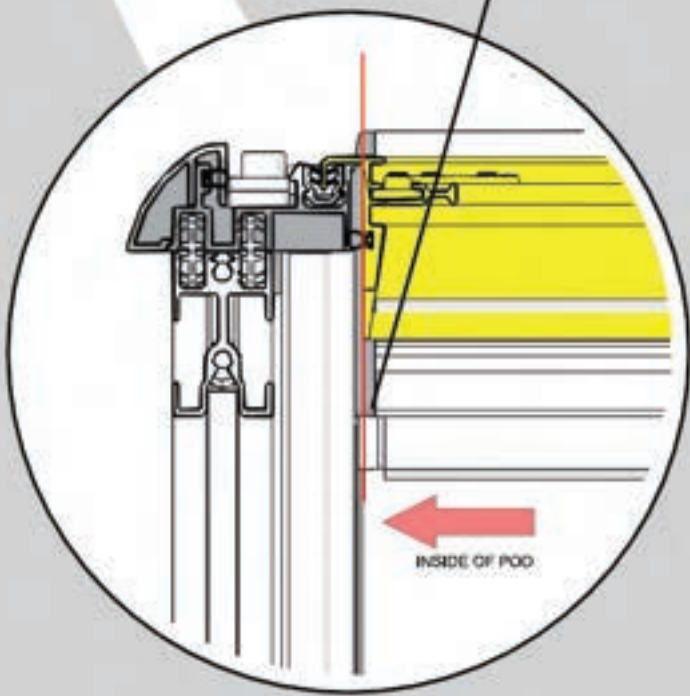

TWO PERSONS MINIMUM

SEE PAGE 10.9

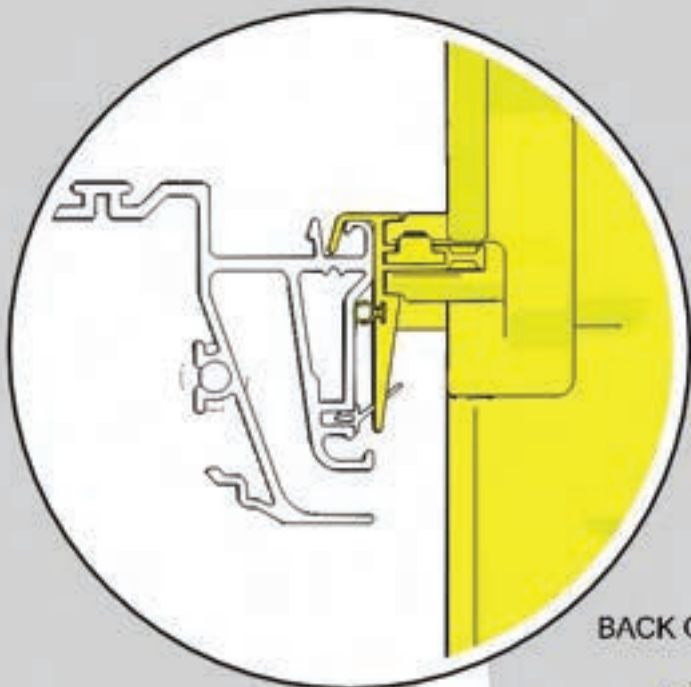

PROFILE VIEW
ALONG HOOP

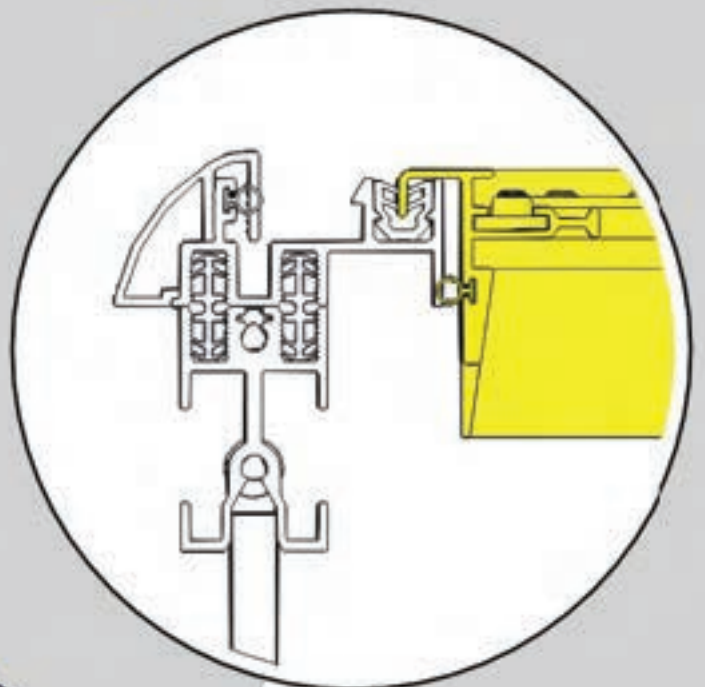

PROFILE VIEW
ALONG SIDE SCREENS

BACK OF POD

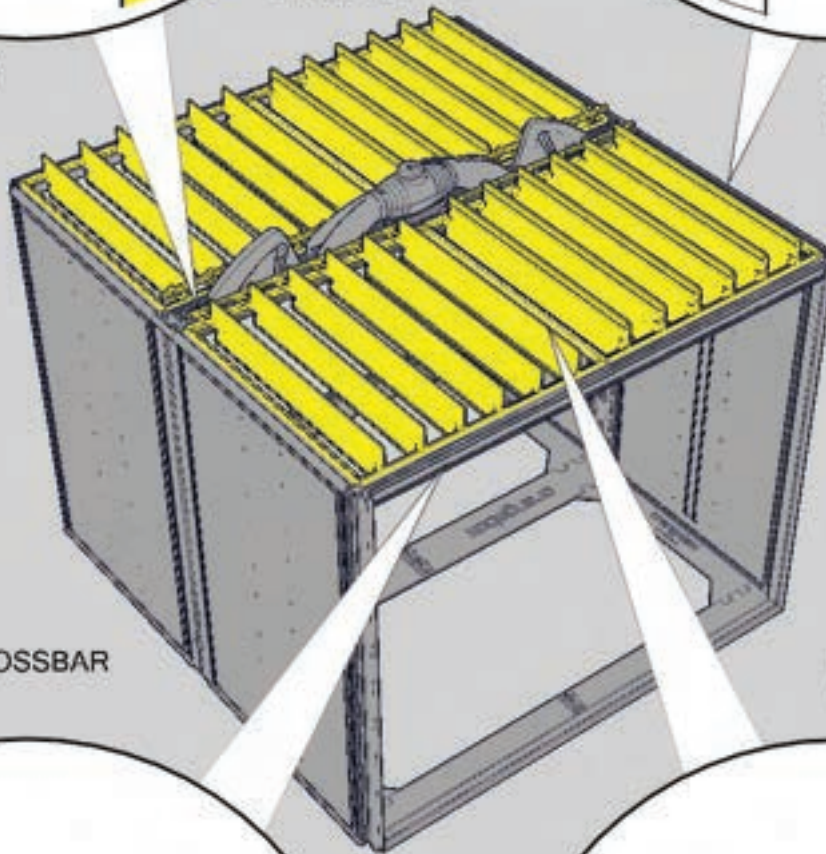

FRONT OF POD (DOOR)

PROFILE VIEW
ALONG FRONT CROSSBAR

PROFILE VIEW
BETWEEN ROOF PANELS

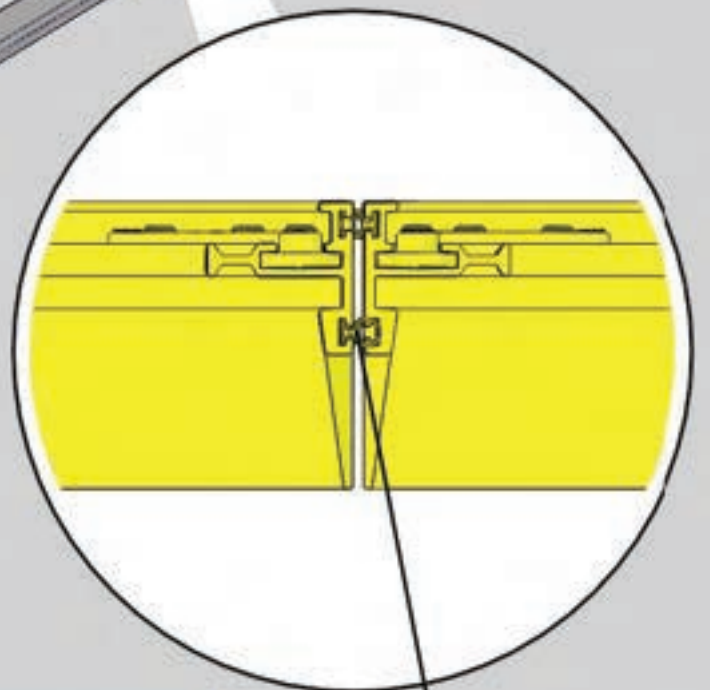
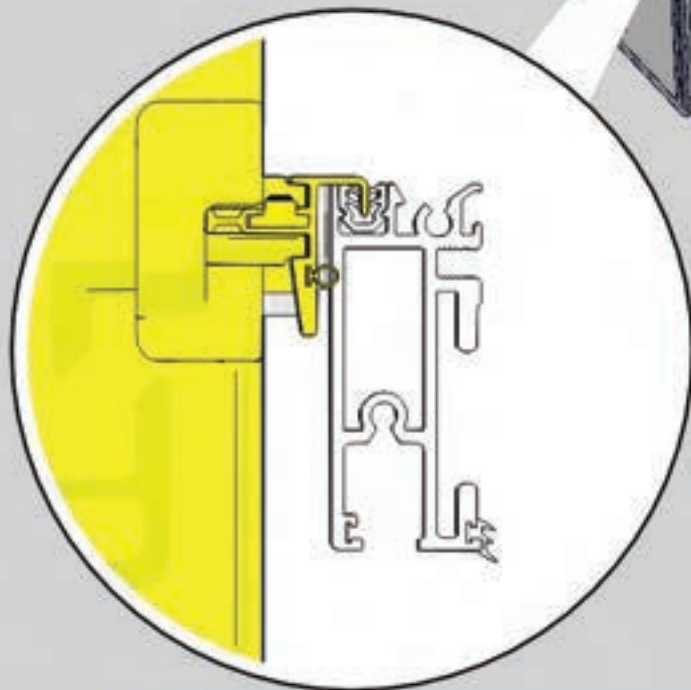

ENSURE THERE ARE NO GAPS
BETWEEN SEALS. SLIDE IF
NECESSARY



ONE PERSON MINIMUM

1 LOCATE ARM INTO LINKAGE MOULDING FIRST. NOTE THAT THE 'L' OR 'R' MATCH UP ON BOTH THE COWEL AND THE ARM

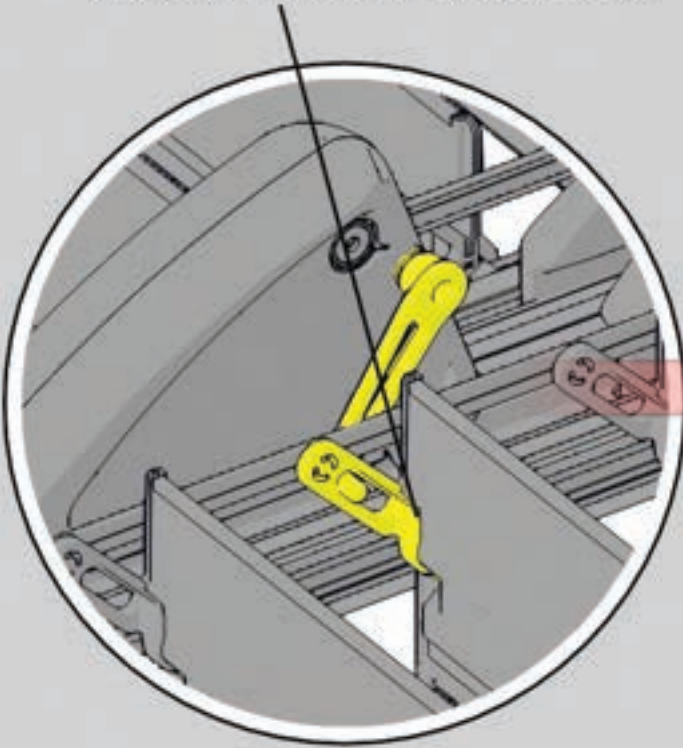

2 THEN SWING ARM INTO POSITION AND LOCATE AS SHOWN. ENSURE BOTH FLAT AREAS LOCATE AS PER THE PHOTO BELOW

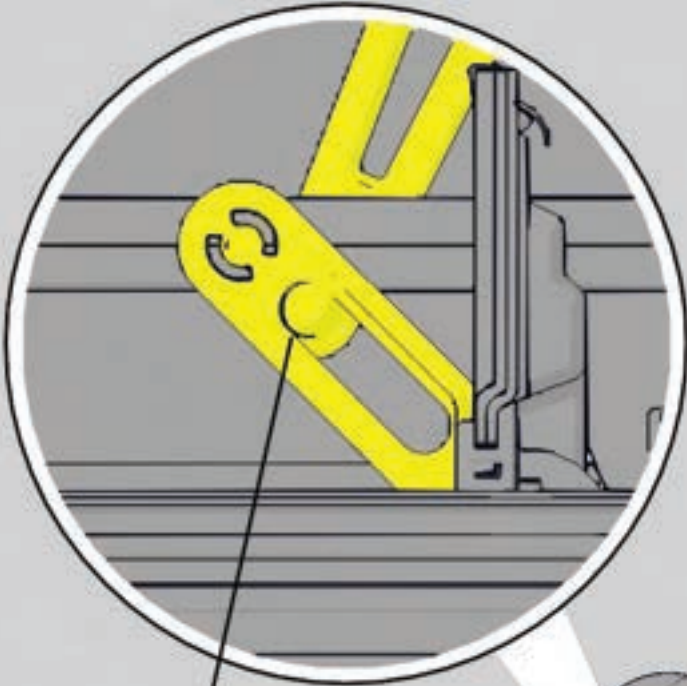
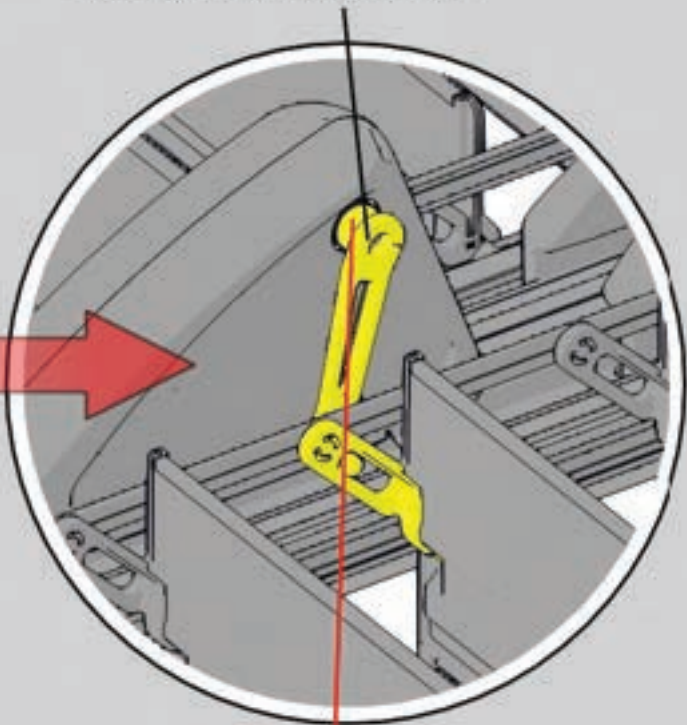

ENSURE ARM IS PUSHED TO TOP OF SLOT

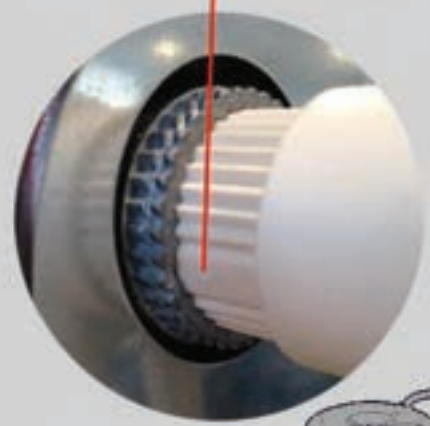

SEE THE KNACK PAGE 10.9

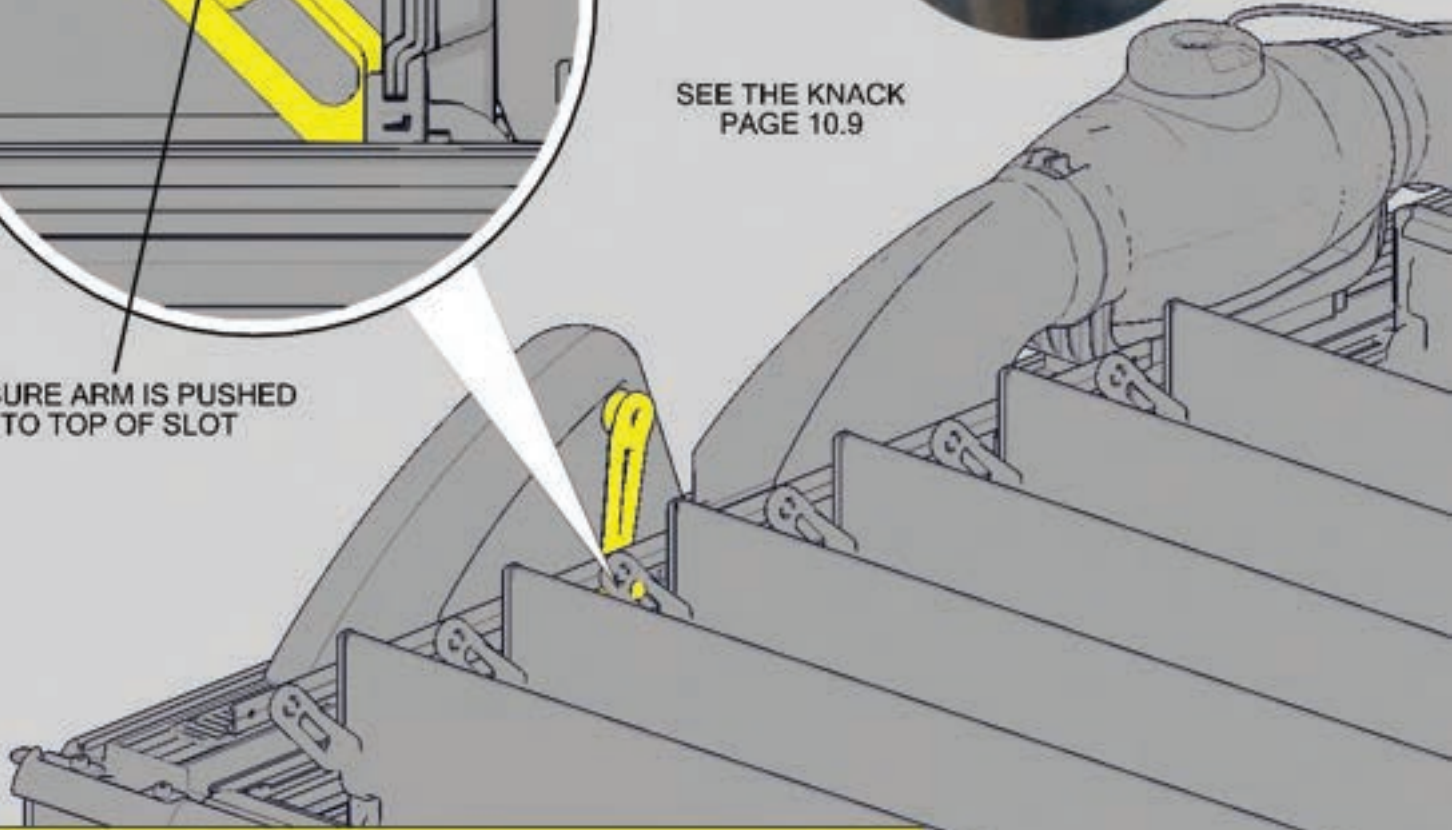

ONE PERSON MINIMUM

FIT ACTUATOR ARMS TEMPORARILY TO CHECK ROOFS BEFORE ADDING COWLS

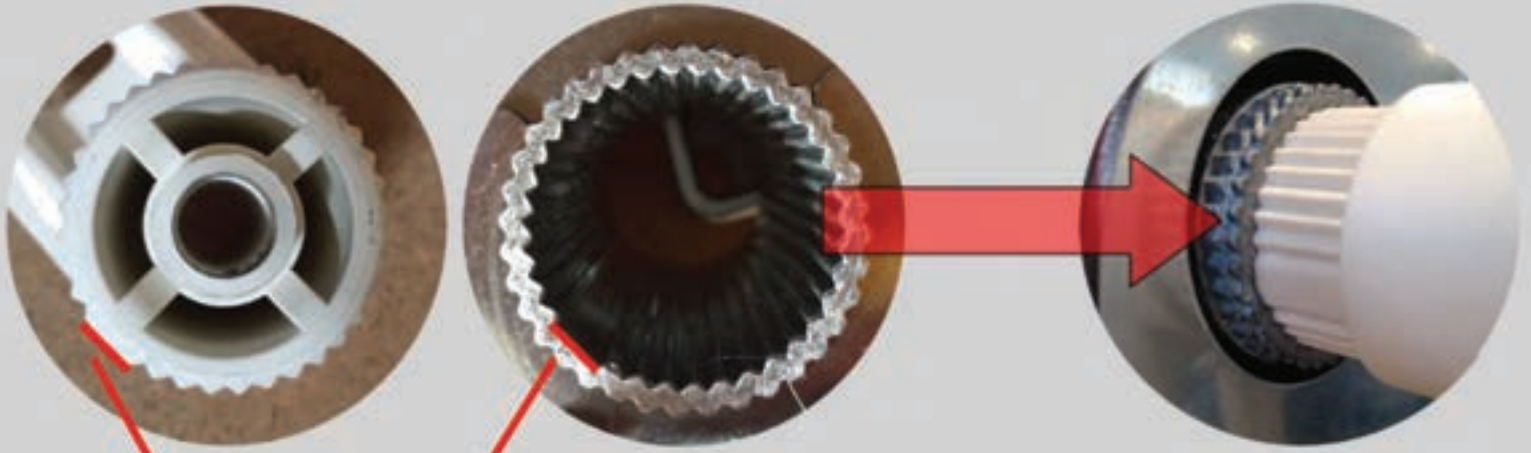

THESE TWO FLAT AREAS MUST LOCATE

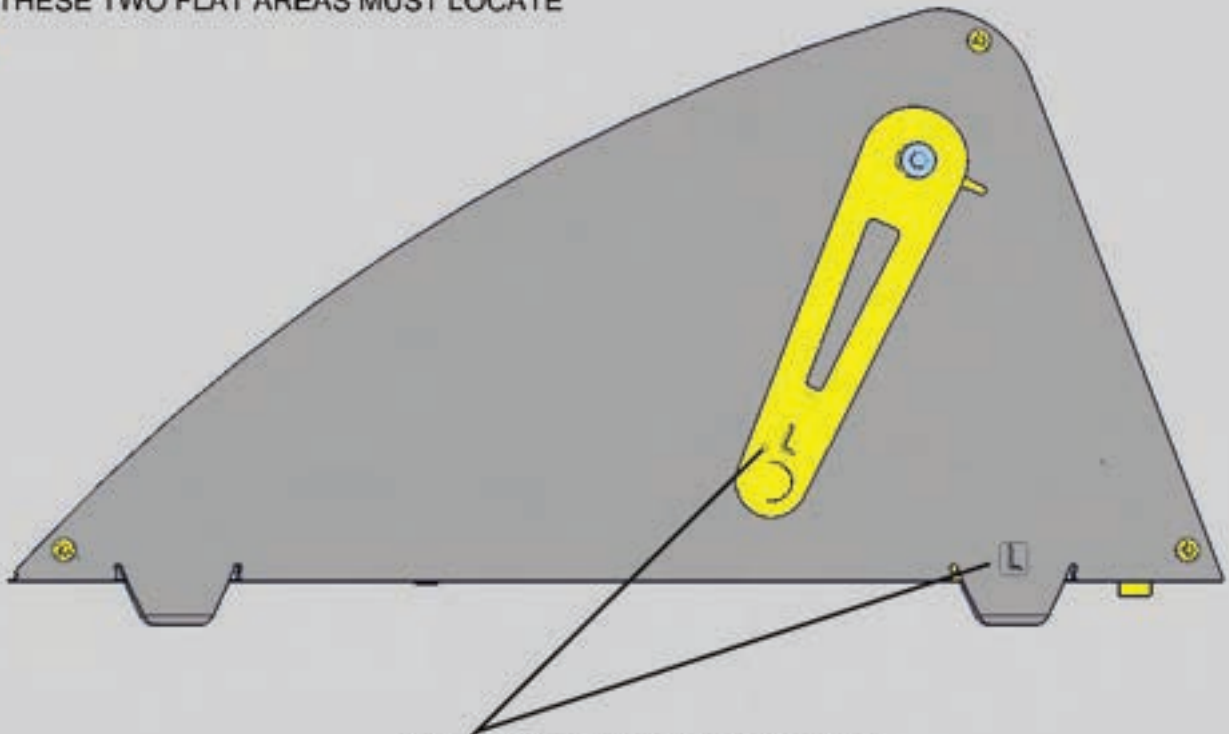

NOTE THAT THE 'L' OR 'R' MATCH UP ON BOTH THE COWL AND THE ARM WHEN THE COWLS ARE PUT ON. DO NOT PUT COWLS ON UNTIL AFTER NEXT STAGE



ONE PERSON MINIMUM

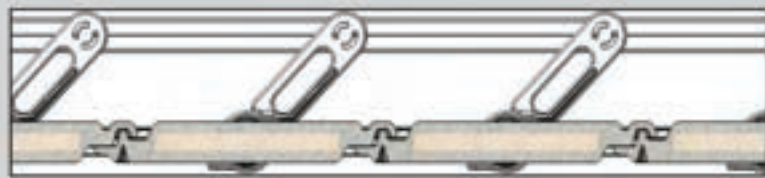
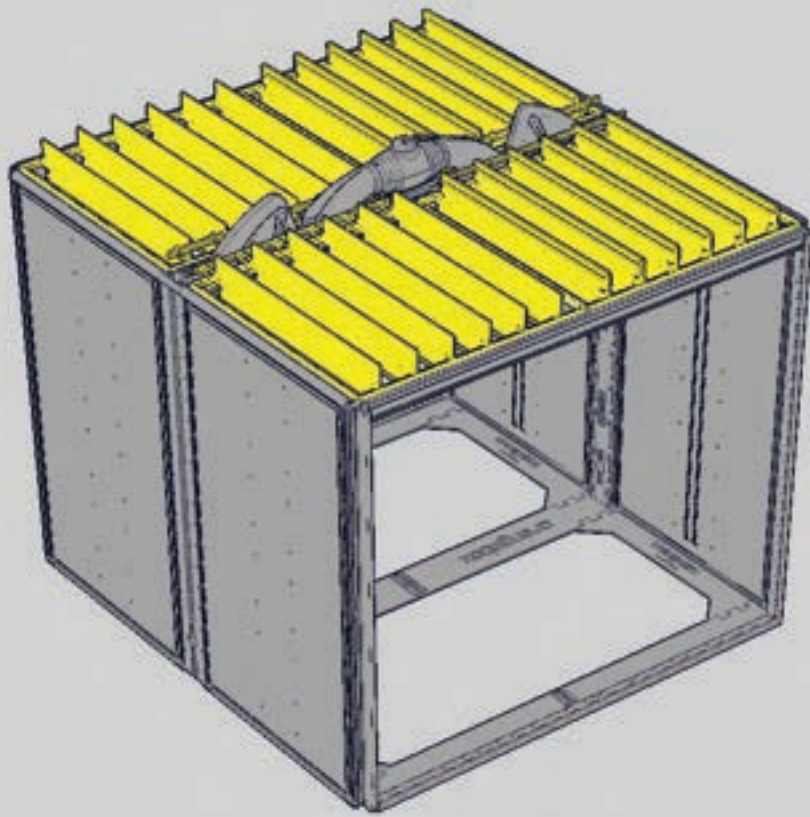

TEST THE ROOFS BY CLOSING.
 PLUG POD IN AND USE SWITCH PANEL
 BUTTONS TO OPERATE ROOF
 IF THEY COMPLETELY CLOSE
 AS SHOWN CONTINUE WITH ASSEMBLY



IF NOT FOLLOW NEXT PAGE
 FOR ADJUSTMENT
 INSTRUCTIONS



ONE PERSON MINIMUM

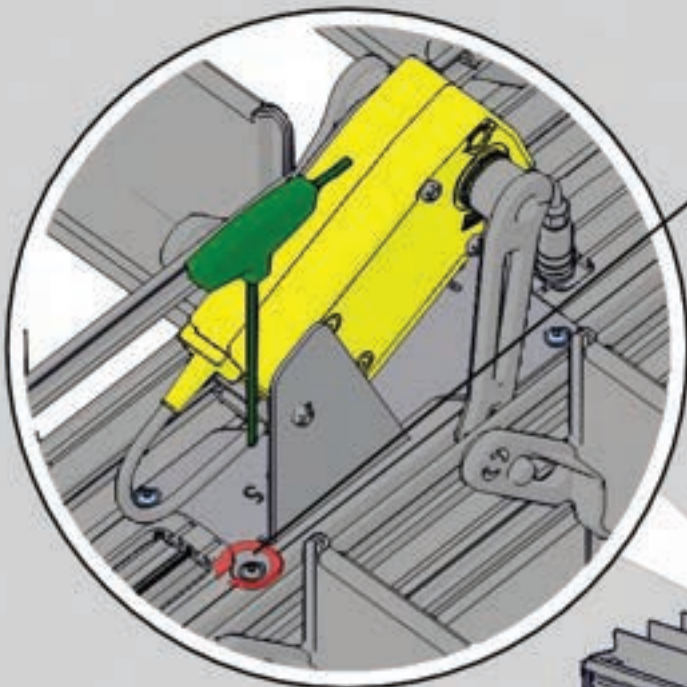

LOOSEN X4 FIXINGS WITH NO 4 T-BAR

TORQUE
5NM 3.69 FT-LBF)

BACK OF POD

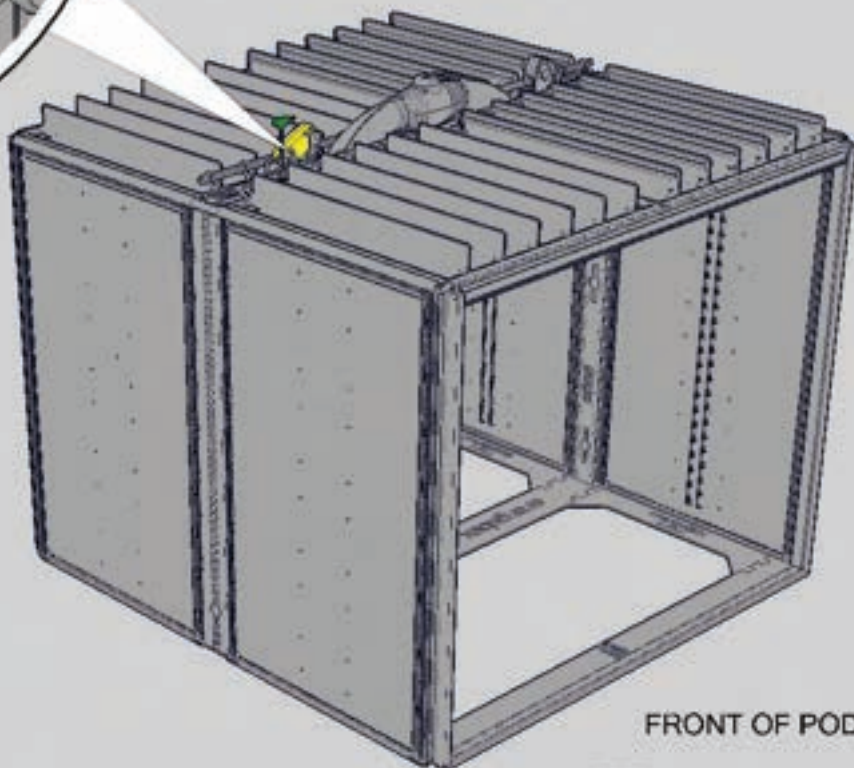

FRONT OF POD (DOOR)

1

IN ORDER TO ADJUST ROOFS TO BE CLOSED TIGHTER, SLIDE THE UNIT TO CREATE MORE TENSION. REMOVE BELIMO COWEL TO ACCESS FIXINGS



ENSURE ROOFS ARE IN OPEN POSITION

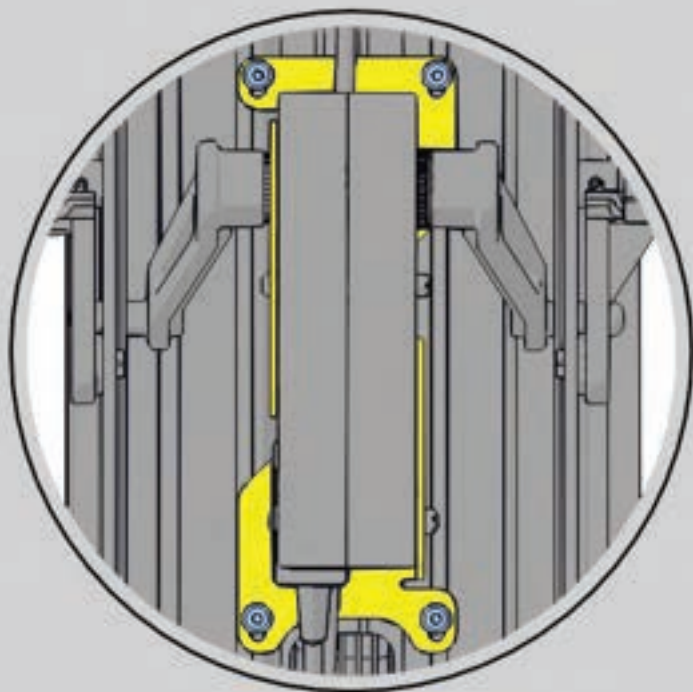

START POSITION
SLIDE TO ADJUST

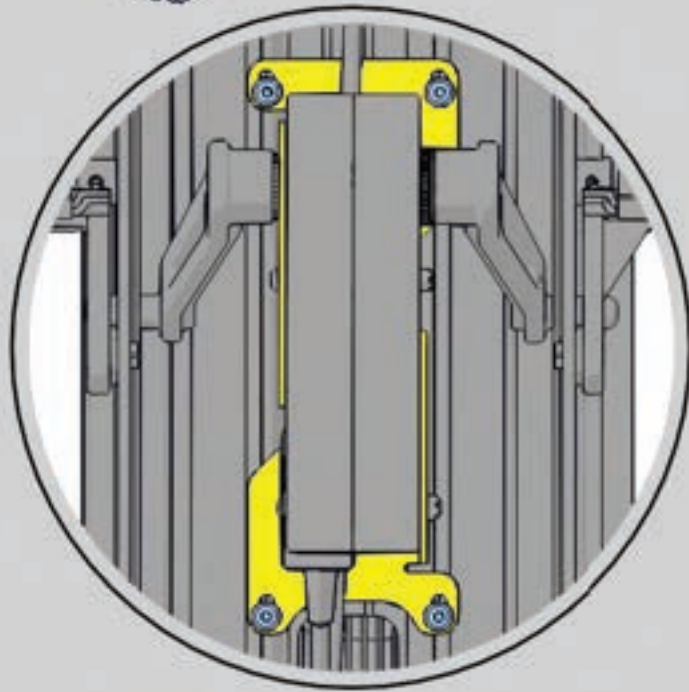

END POSITION - NOTE
FIXING POSITIONS



ONE PERSON MINIMUM

SEE THE KNACK PAGE 10.10

1 SECURE ARMS THROUGH USING BOLTS AND T-BAR

TORQUE
8NM (5.90 FT-LBF)

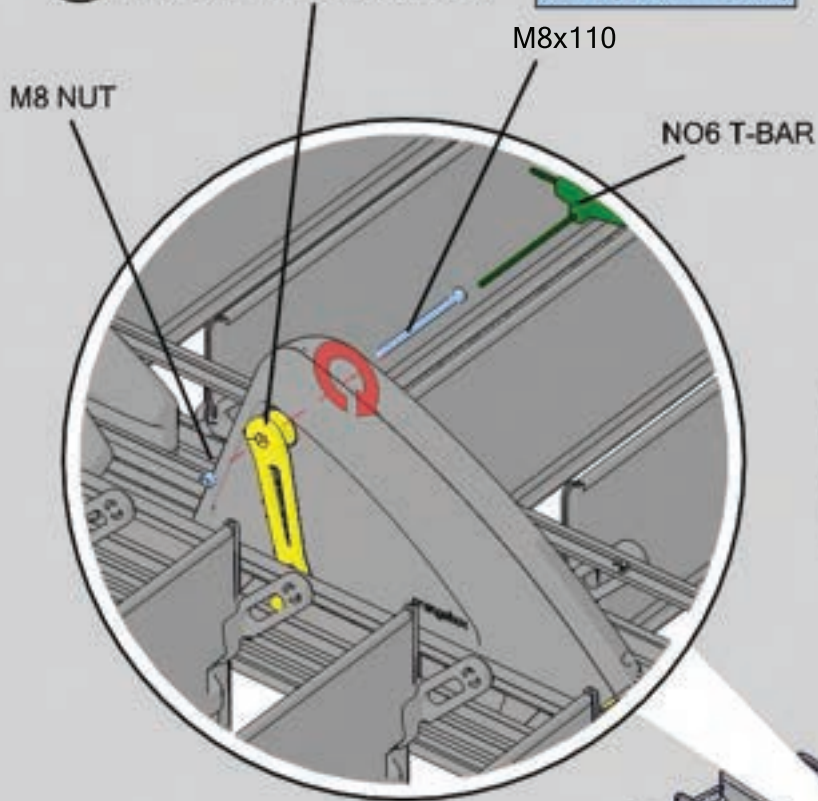

NOTE: M8 NUT ALREADY INSERTED IN DRIVE BAR

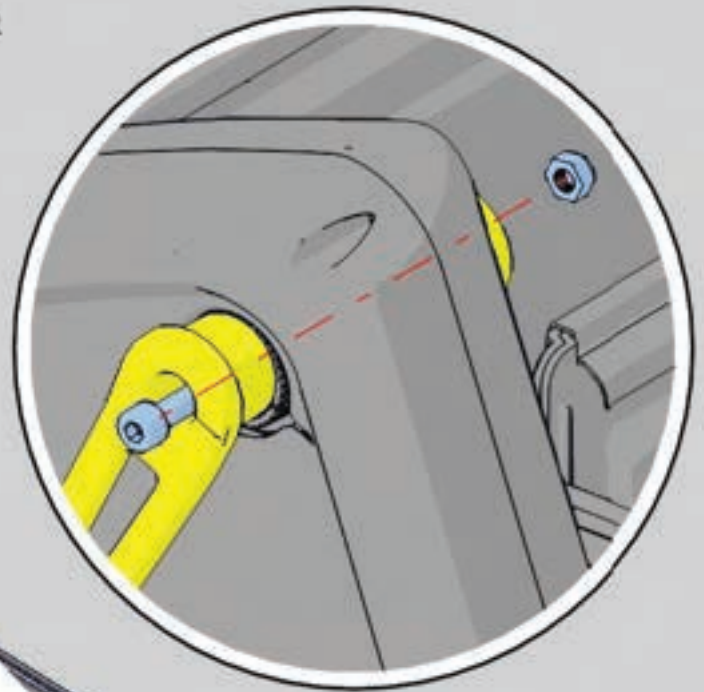

BACK OF POD

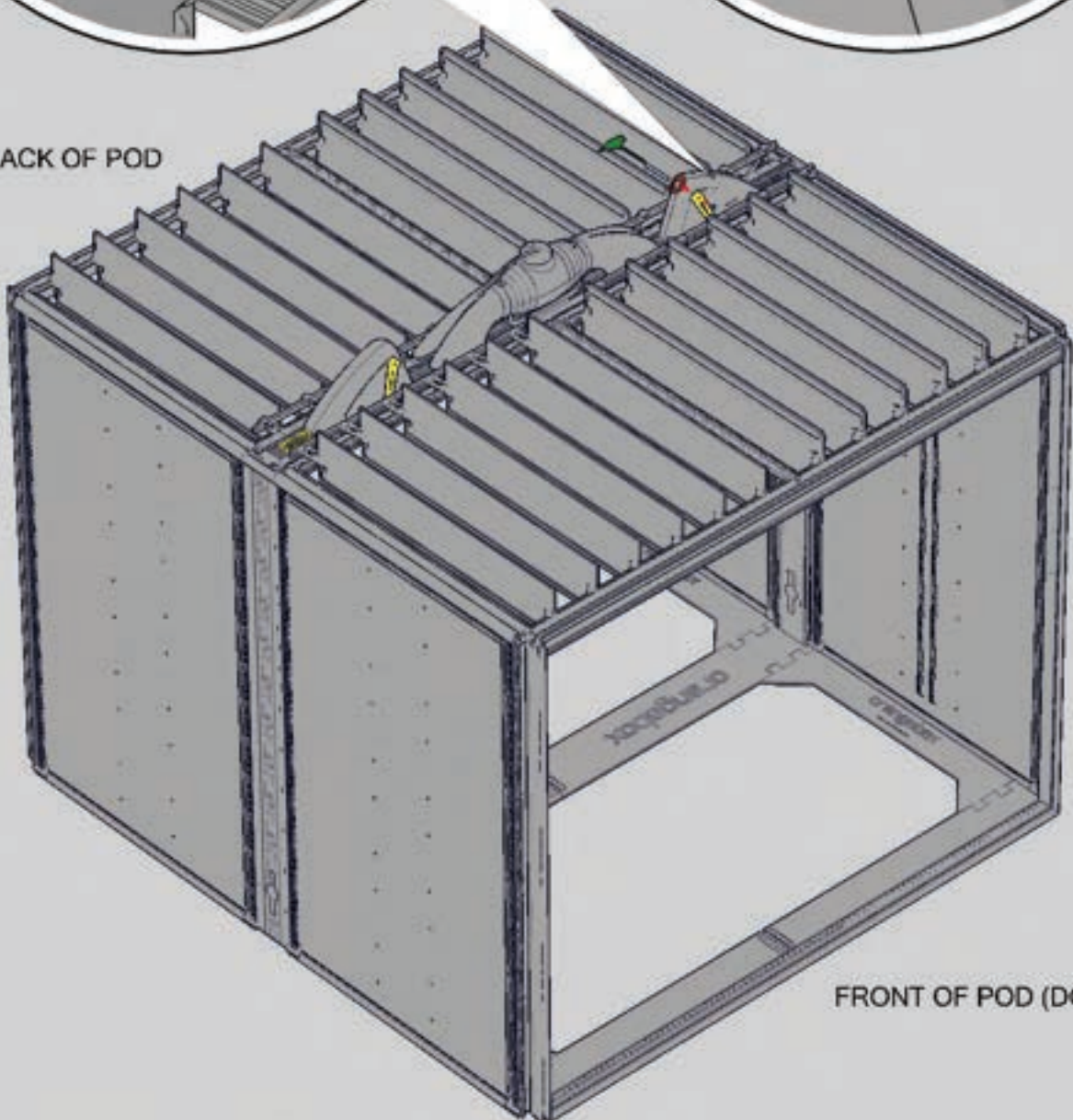

ONE PERSON MINIMUM

Assembly sequence

Upholstery panels

section

* NO UNAUTHORISED PERSONNEL PERMITTED TO PARTICIPATE IN ASSEMBLY (ORANGEBOX CERTIFIED PERSONNEL ONLY)



*APPROPRIATE PPE MUST BE WORN AT ALL TIMES DURING ASSEMBLY OF ORANGEBOX PRODUCTS

*PART ASSEMBLED PODS MAY NOT BE LEFT UNATTENDED UNLESS STRUCTURALLY SOUND



DUE TO TOLERANCE BUILD UP ON THE UPHOLSTERY PANELS THE BELOW TWO MOULDINGS MAY ONLY WORK IN CERTAIN CONFIGURATIONS. THE BELOW IS A GUIDELINE. ALWAYS TRY THESE MOULDINGS BEFORE REMOVING

SQUARE POD

FABRIC	ANTI-SLIP MOULDING		BOTTOM CORNER TRIM
			
<u>EXTERNAL POD</u>	CORNER SIDE	HOOP SIDE	
GABRIEL EUROPOST	✗	✗	✗
KVADRAT DIVINA 3	✗	✓	✗
CAMIRA BLAZER	✗	✓	✓

<u>INTERNAL POD</u>	HOOP SIDE	CORNER SIDE	
GABRIEL EUROPOST	✓	✓	N/A
KVADRAT DIVINA 3	✓	✓	N/A
CAMIRA BLAZER	✓	✓	N/A



TWO PERSONS MINIMUM

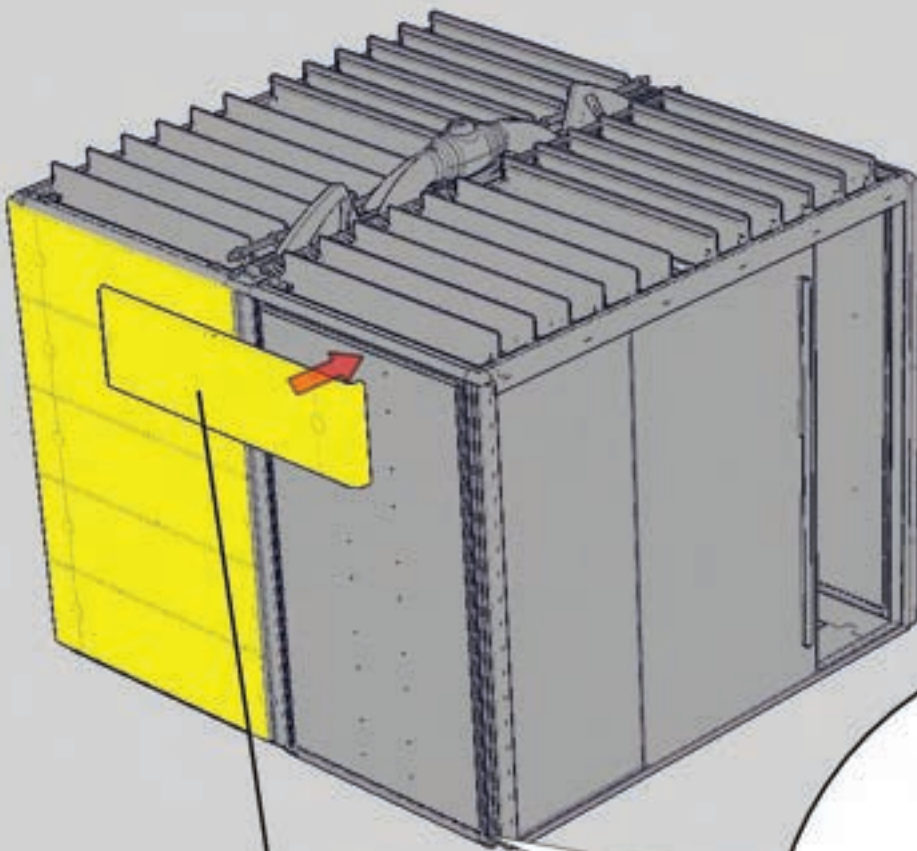

ADD PANELS ON TO THE POD EXTERNAL STARTING FROM THE TOP AND WORKING DOWN

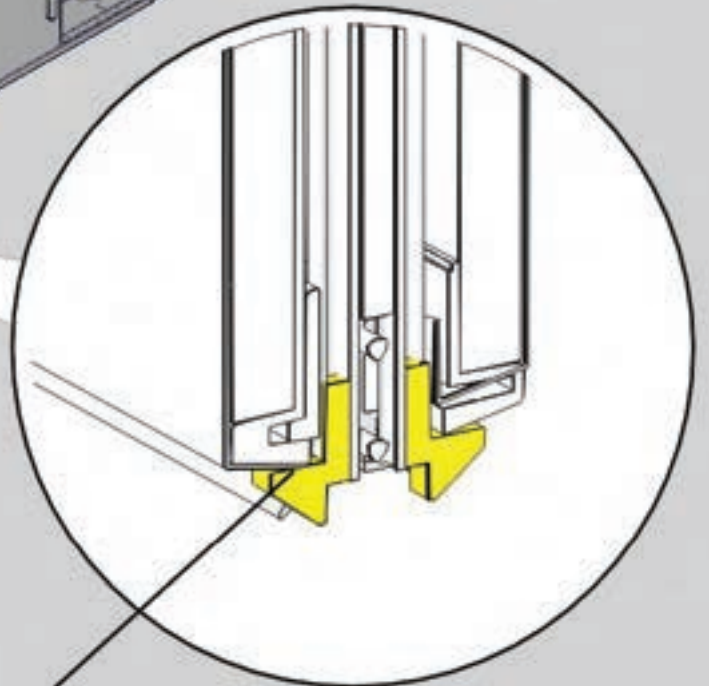

ENSURE THAT THE UPHOLSTERY PANELS ARE SAT ON THESE BLOCKS AT THE BOTTOM. PACK THESE IF NECESSARY.

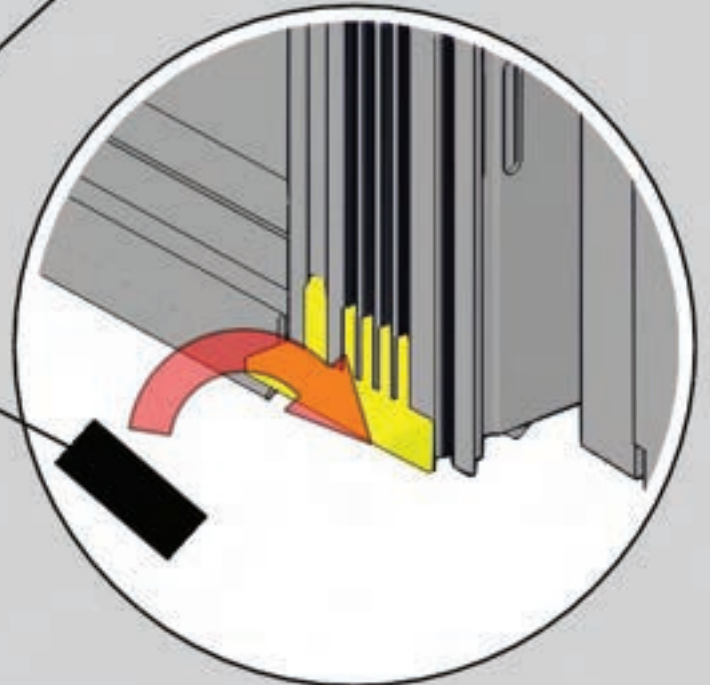

TWO PERSONS MINIMUM

SEE PAGE 10.15 + 10.17

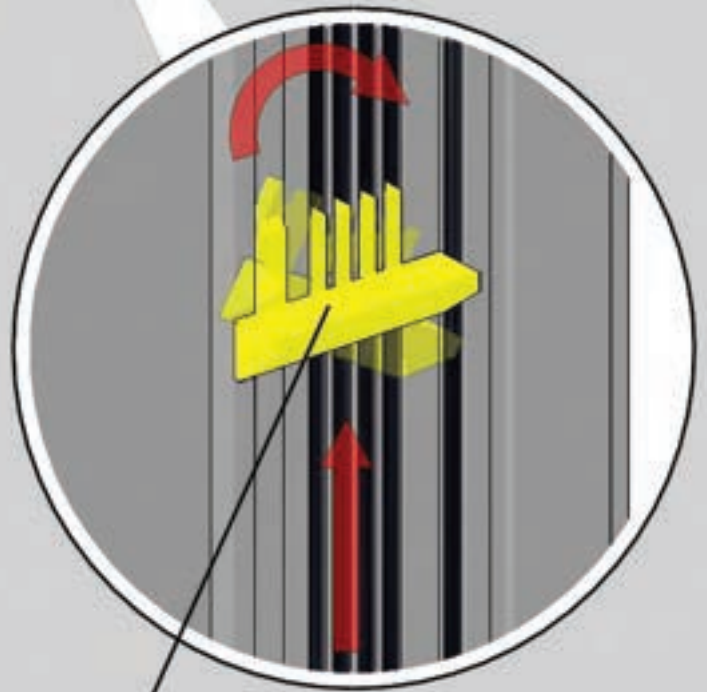
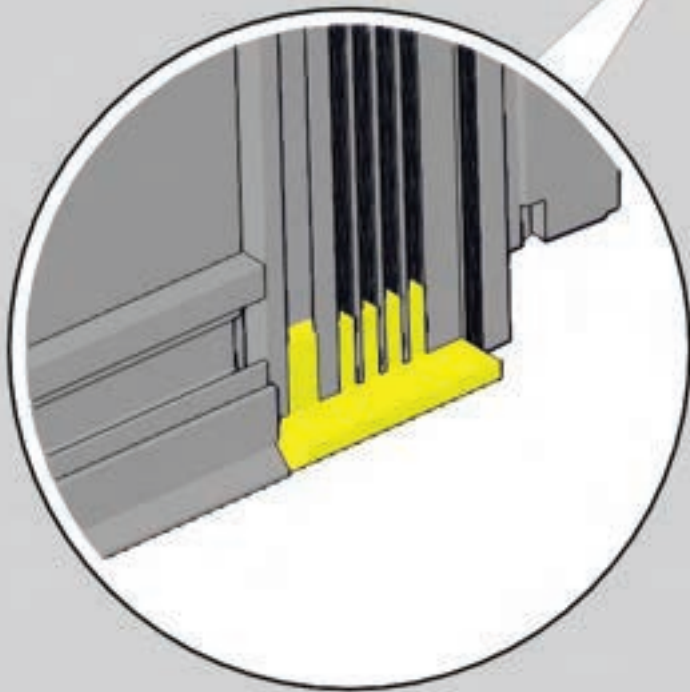
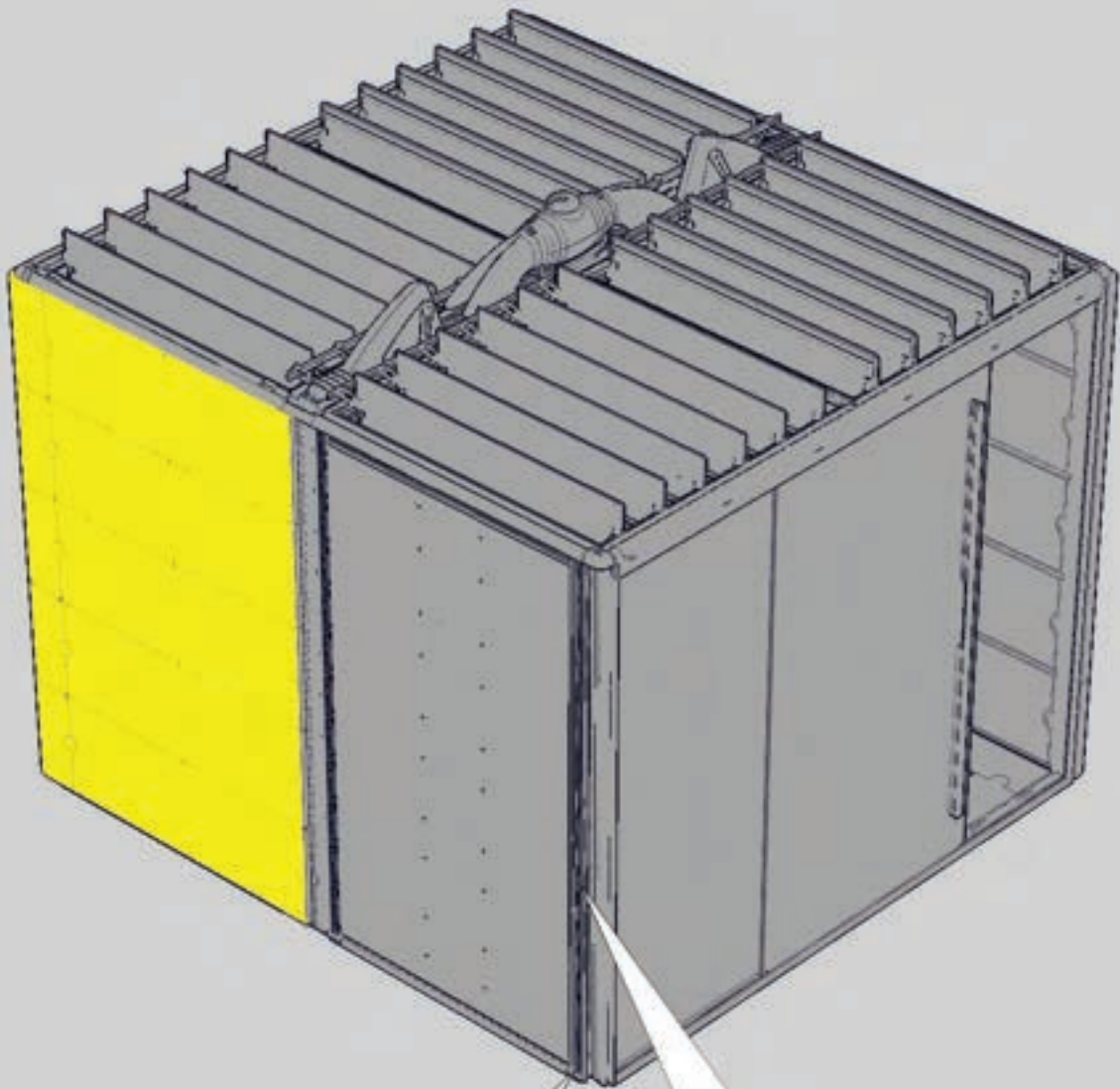

WHENEVER POD SHIPS WITH THESE MOULDINGS (OUTSIDE ONLY),
THEY SHOULD BE REMOVED AS PART OF INSTALL PROCESS



TWO PERSONS MINIMUM

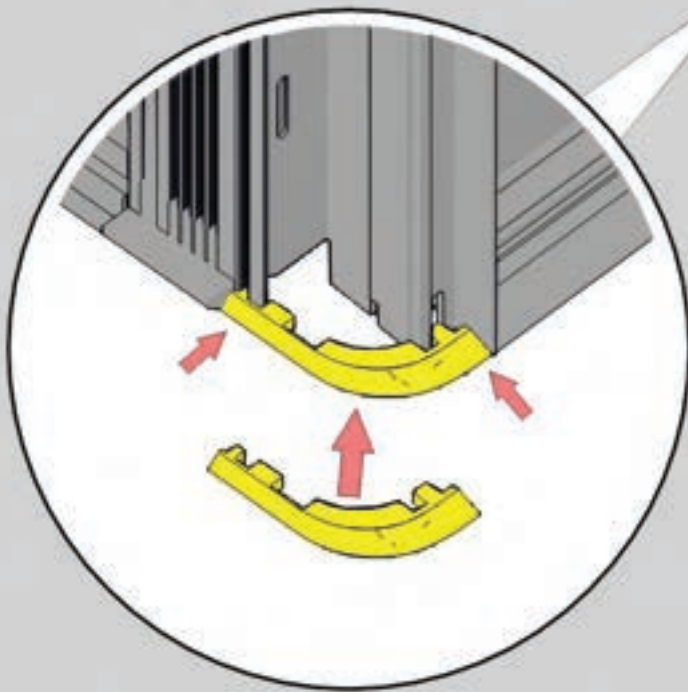
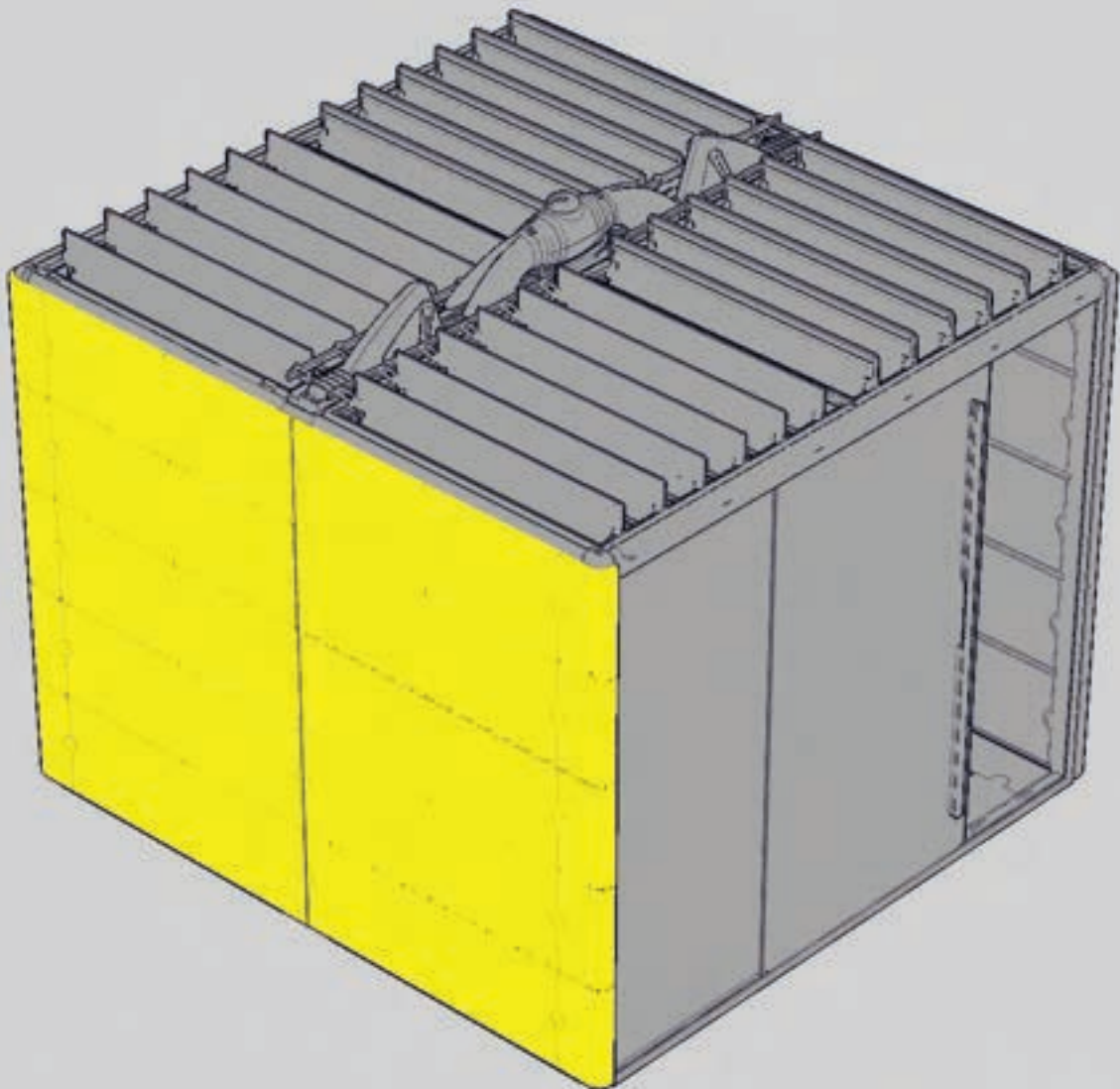

1 PUSH MOULDING INTO BOTTOM OF EXTRUSION AS SHOWN

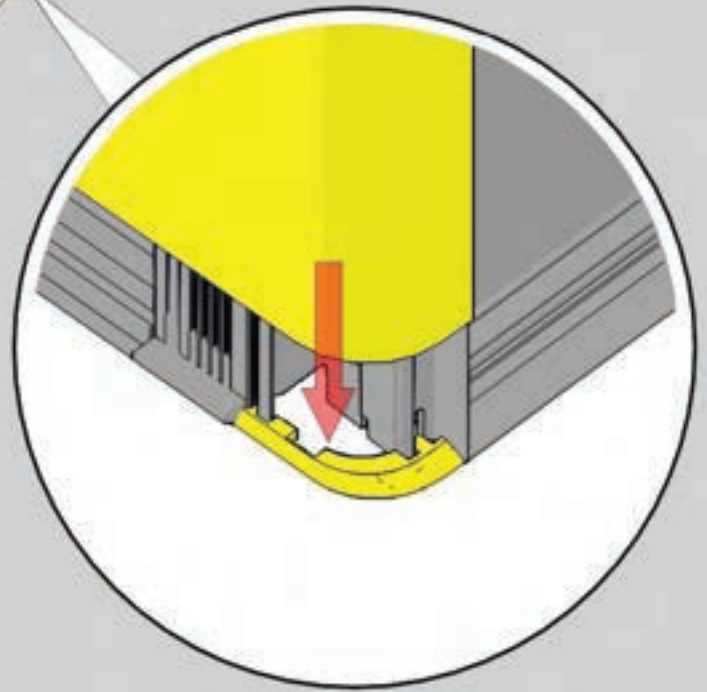

2 MAKE SURE MOULDING IS IN PLACE FIRST. THEN LOCATE PANEL



TWO PERSONS MINIMUM

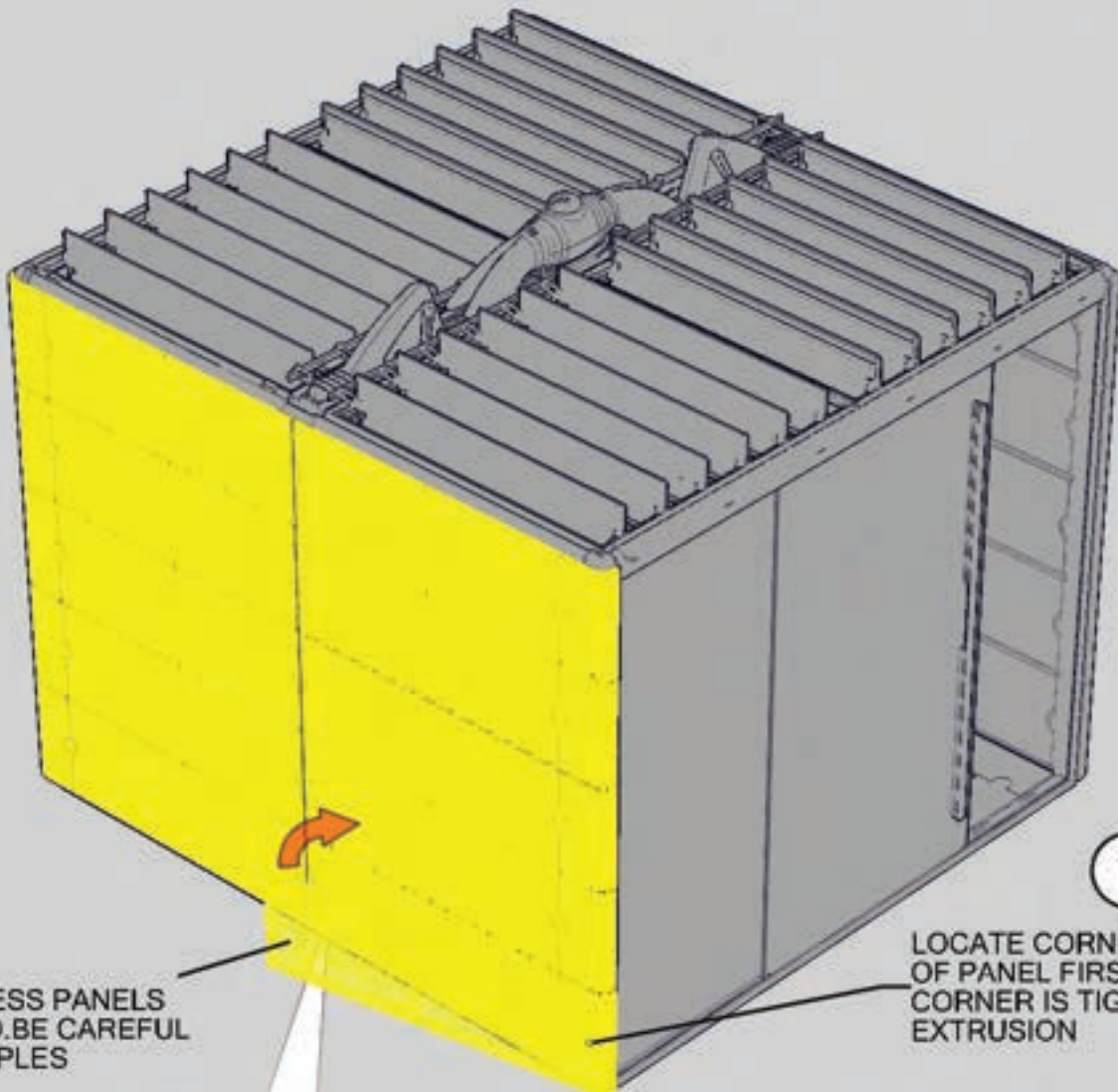

GENTLY PRESS PANELS ON BY HAND. BE CAREFUL OF ANY STAPLES

1
LOCATE CORNER SIDE OF PANEL FIRST ENSURING CORNER IS TIGHT AGAINST EXTRUSION

PROFILE VIEWS LOOKING DOWN EXTRUSIONS

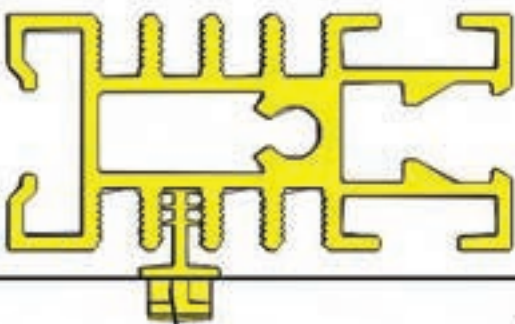

UPHOLSTERED PANEL

NOTE WHERE PANEL CLIPS LOCATE IN TO ON LEFT HAND SIDE OF SCREEN

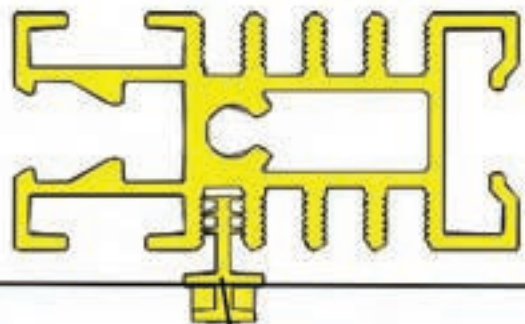

UPHOLSTERED PANEL

NOTE WHERE PANEL CLIPS LOCATE IN TO ON RIGHT HAND SIDE OF SCREEN



TWO PERSONS MINIMUM

SEE PAGE 10.17

SECTION VIEW OF POJ

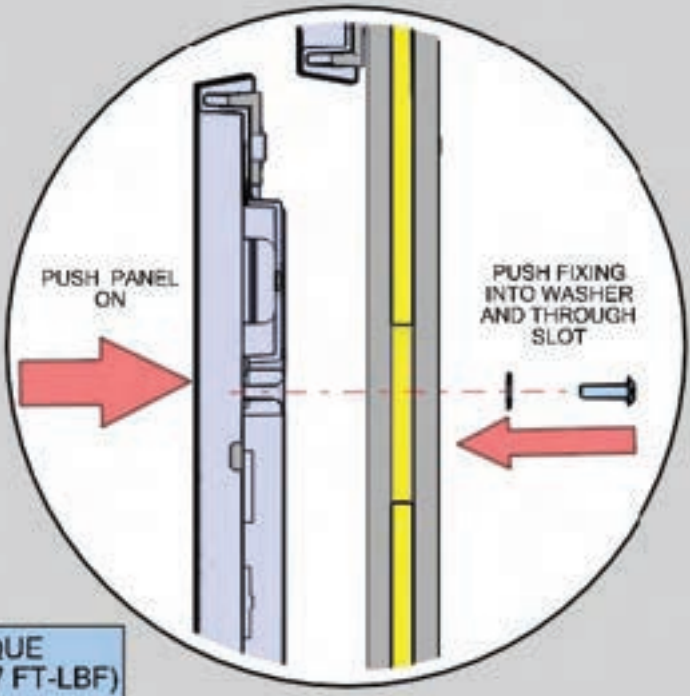
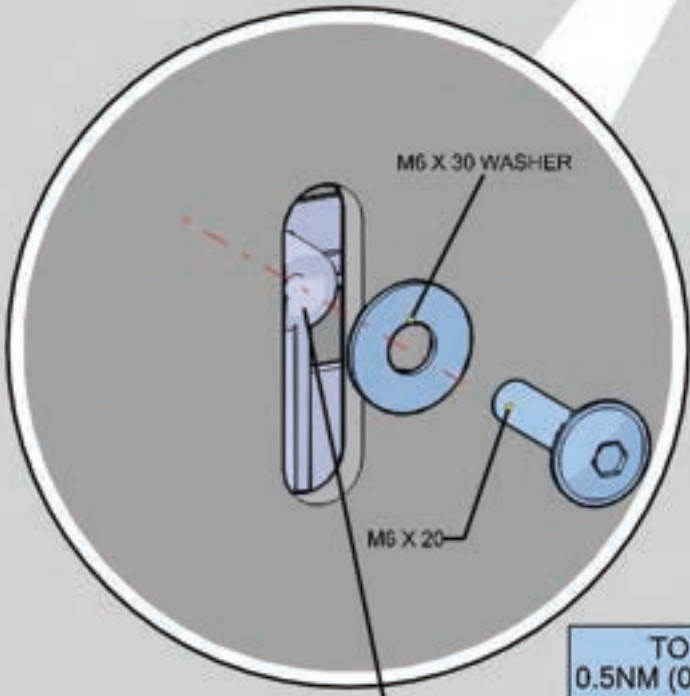
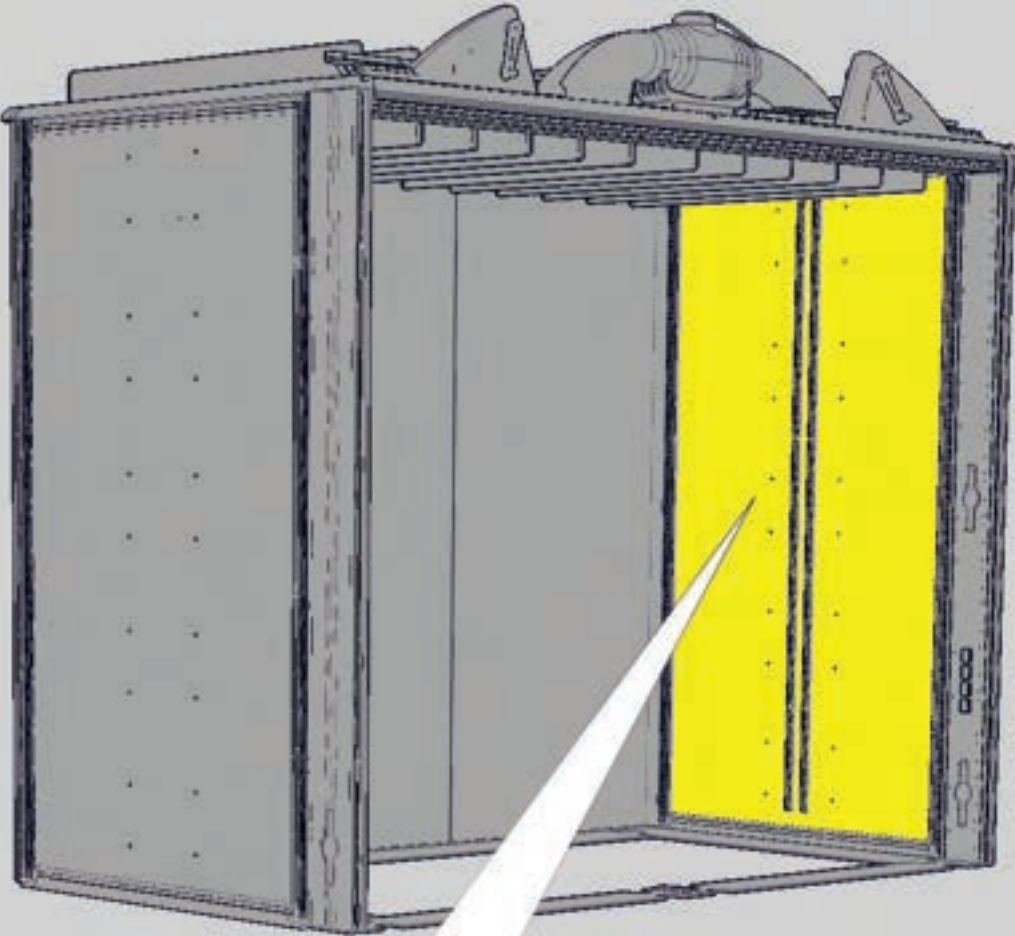

TORQUE
0.5NM (0.37 FT-LBF)

EXTERNAL PANELS HAVE BOSSES WHICH WILL ALIGN WITH HOLES IN MDF BOARD. USE THE PROVIDED WASHERS AND FIXINGS TO ATTACH THE PANELS TO THE OUTSIDE

SIDE PROFILE VIEW OF PANEL BEING ATTACHED TO SCREEN



TWO PERSONS MINIMUM

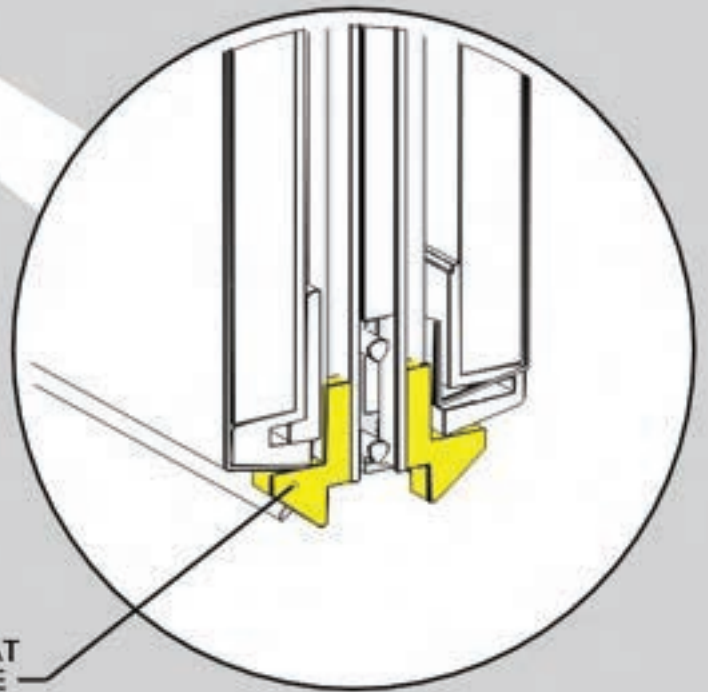
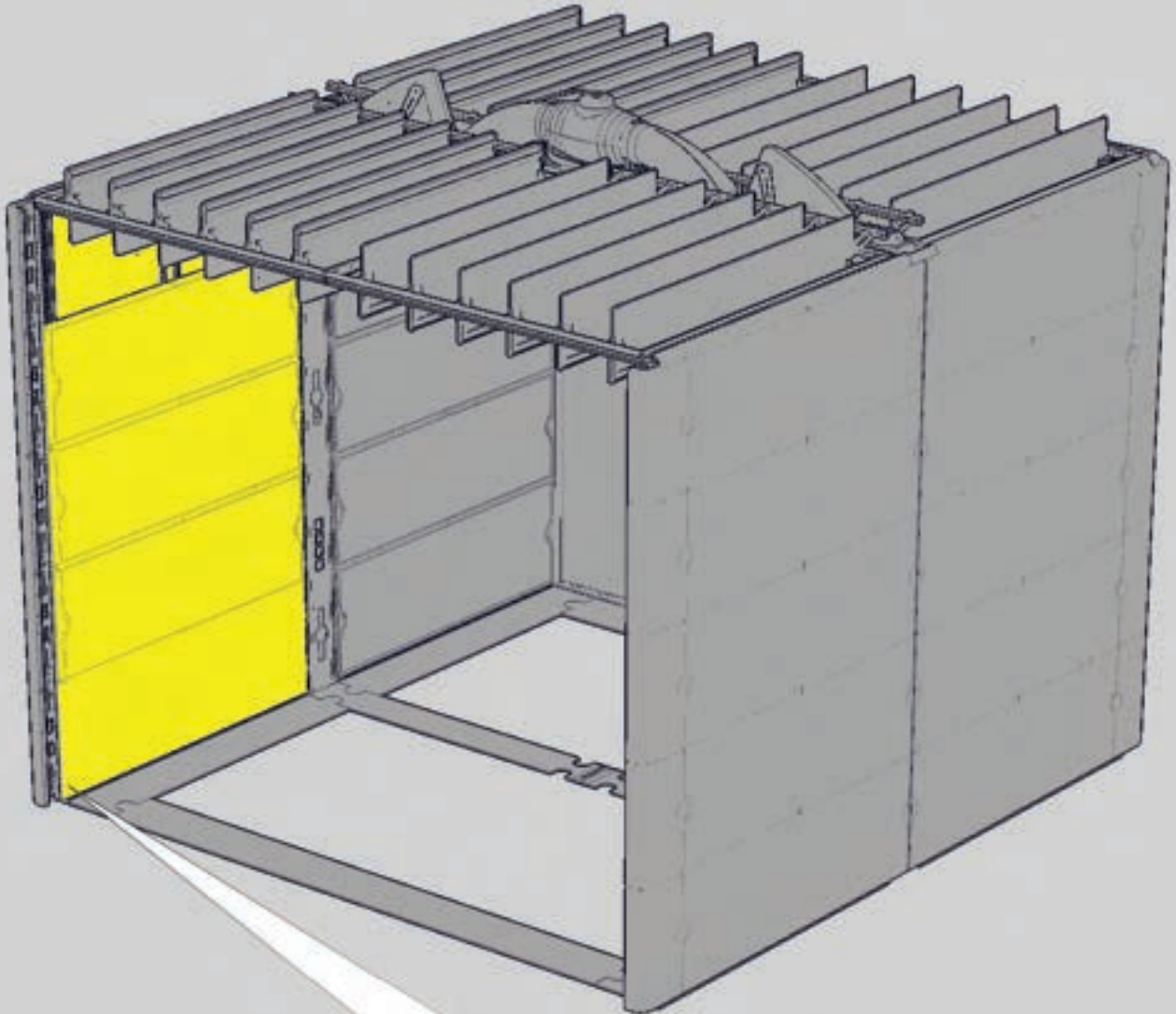

ENSURE THAT THE UPHOLSTERY PANELS ARE SAT ON THESE BLOCKS AT THE BOTTOM. PACK THESE IF NECESSARY.



TWO PERSONS MINIMUM

SEE PAGE 156

NOTE WHERE PANEL CLIPS INTO PLASTIC STRIPS IN CENTRE OF SCREEN

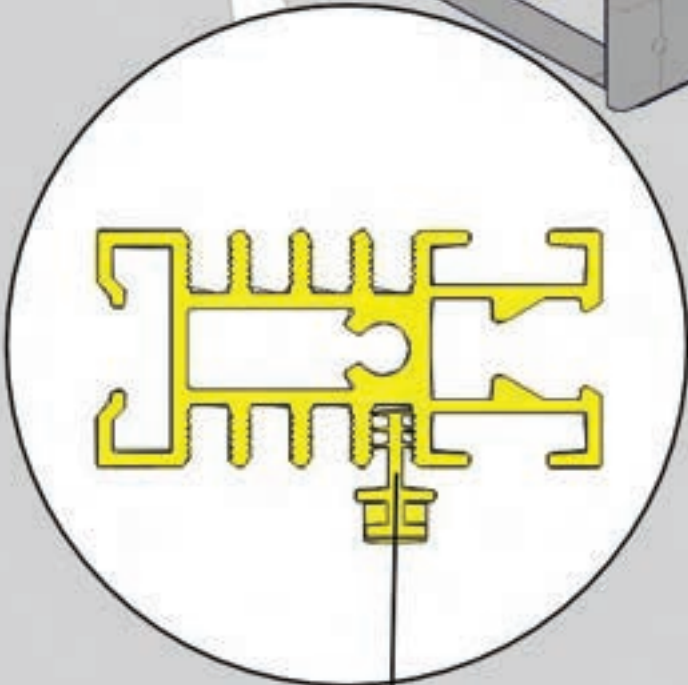
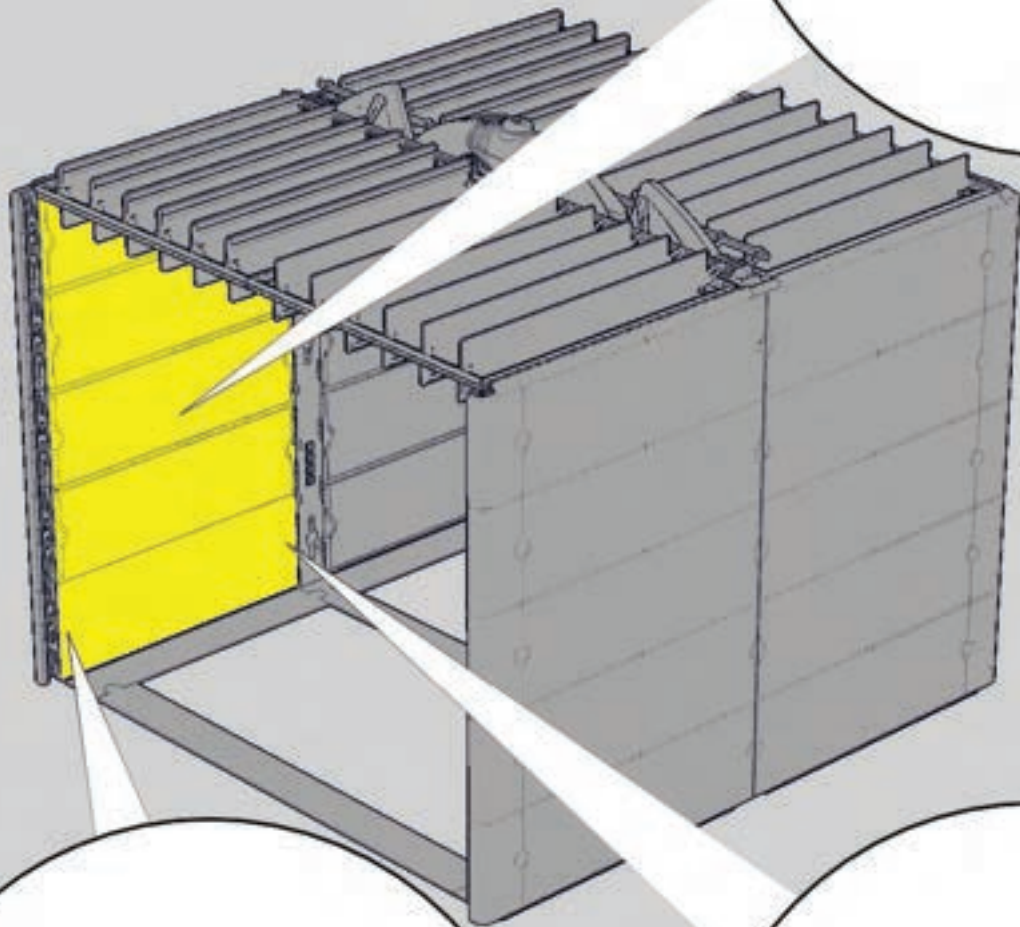
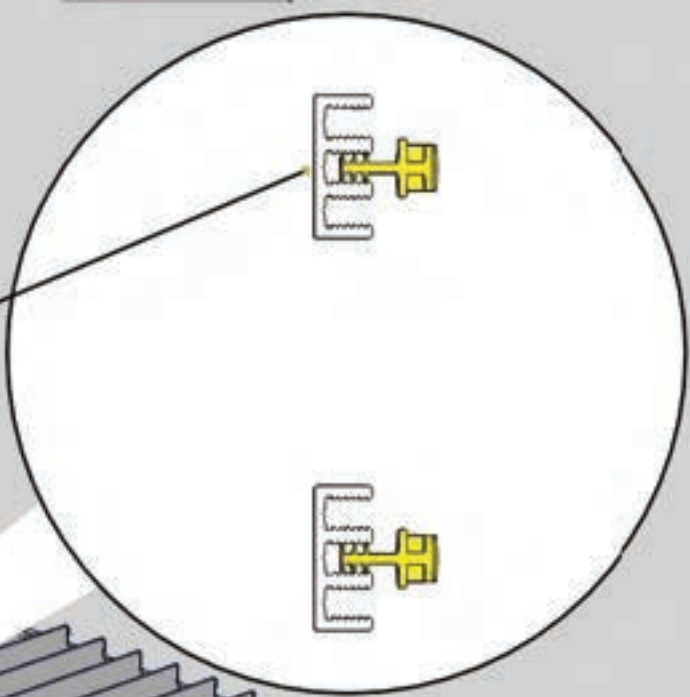

NOTE WHERE PANEL CLIPS IN TO EXTRUSION ON RIGHT SIDE OF SCREEN

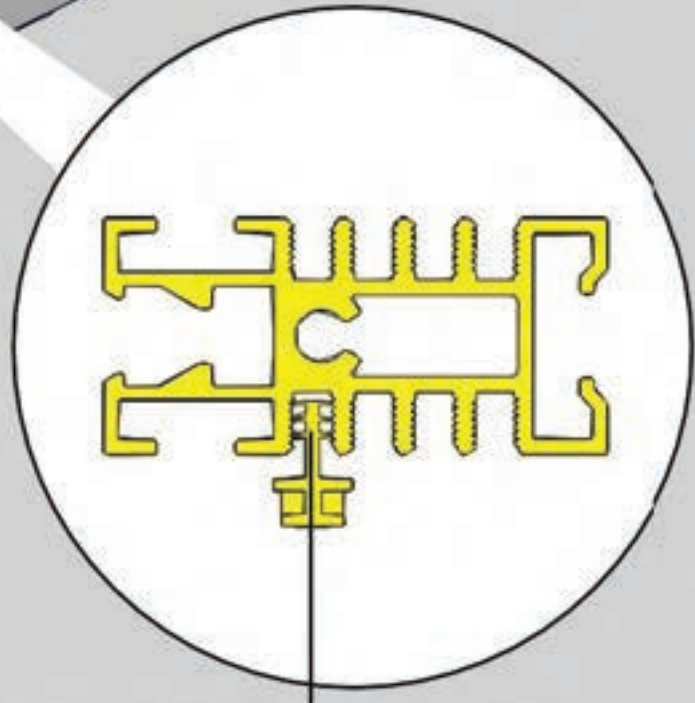

NOTE WHERE PANEL CLIPS IN TO EXTRUSION ON LEFT SIDE OF SCREEN



TWO PERSONS MINIMUM

SEE PAGE 10.17

Assembly sequence

Front and back glass

section

* NO UNAUTHORISED PERSONNEL PERMITTED TO PARTICIPATE IN ASSEMBLY (ORANGEBOX CERTIFIED PERSONNEL ONLY)

* APPROPRIATE PPE MUST BE WORN AT ALL TIMES DURING ASSEMBLY OF ORANGEBOX PRODUCTS

* PART ASSEMBLED PODS MAY NOT BE LEFT UNATTENDED UNLESS STRUCTURALLY SOUND



orangebox

air³

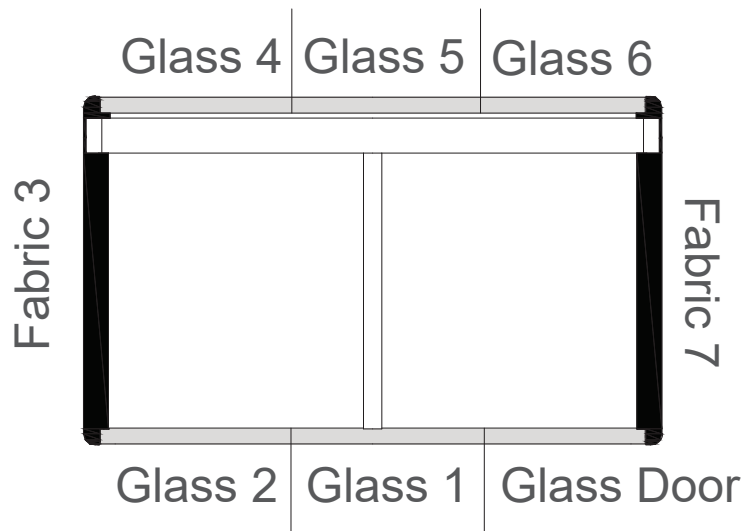

Glass Door: 1160w x 2189h

Glass 1: 675w x 2167h

Glass 2: 875w x 2167h

Glass 4: 875w x 2167h

Glass 5: 875w x 2167h

Glass 6: 875w x 2167h

Graphic Application Notes:

Dimensions provided are taken from the full glass panel size. Due to the floor level adjustments of the glass, the graphics will have to be cut down to the actual visual size during application on site. We cannot provide the actual visual size as this will vary from pod to pod due to tolerances.

air 23

orangebox

air³

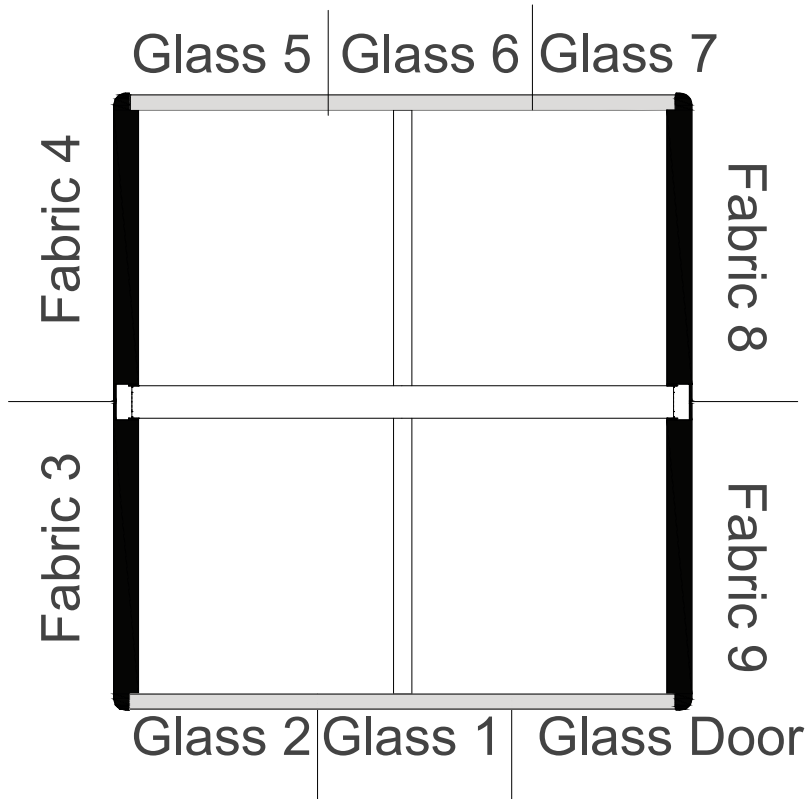

Glass Door: 1160w x 2189h

Glass 1: 680w x 2167h

Glass 2: 875w x 2167h

Glass 5: 875w x 2167h

Glass 6: 875w x 2167h

Glass 7: 875w x 2167h

Graphic Application Notes:

Dimensions provided are taken from the full glass panel size. Due to the floor level adjustments of the glass, the graphics will have to be cut down to the actual visual size during application on site. We cannot provide the actual visual size as this will vary from pod to pod due to tolerances.

air 25

orangebox

air³

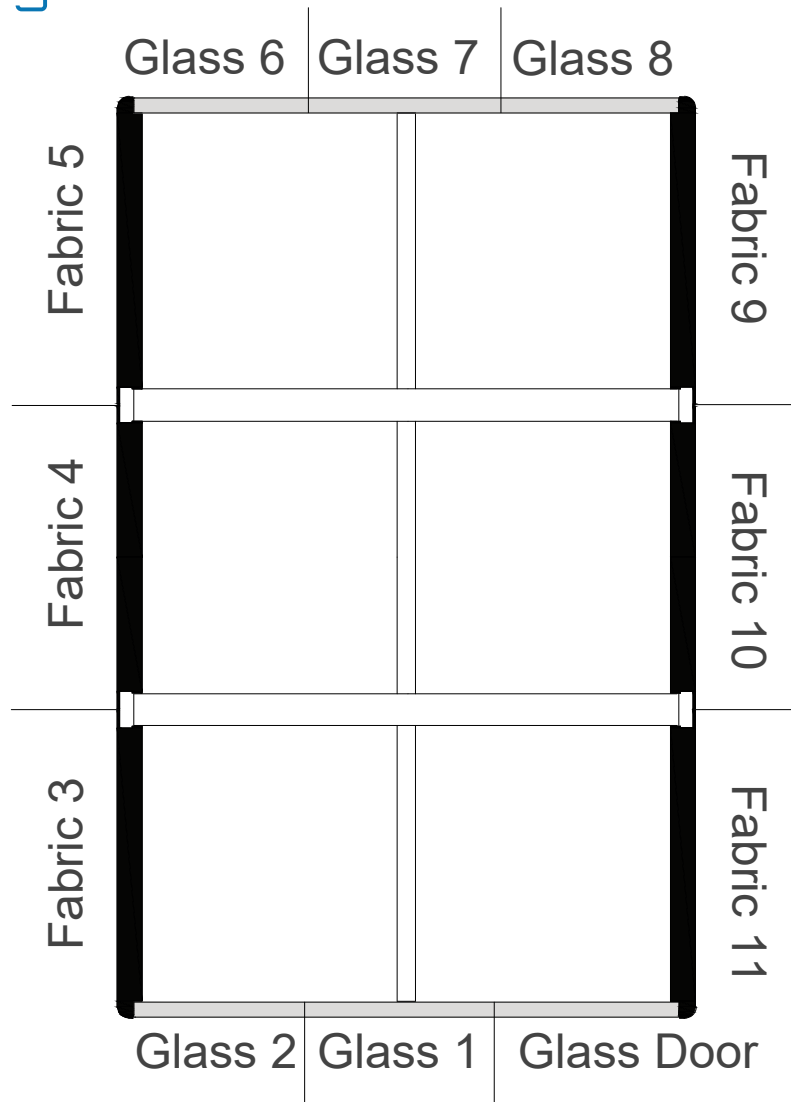

air 27

Glass Door: 1160w x 2189h

Glass 1: 680w x 2167h

Glass 2: 875w x 2167h

Glass 6: 875w x 2167h

Glass 7: 875w x 2167h

Glass 8: 875w x 2167h

Graphic Application Notes:

Dimensions provided are taken from the full glass panel size. Due to the floor level adjustments of the glass, the graphics will have to be cut down to the actual visual size during application on site. We cannot provide the actual visual size as this will vary from pod to pod due to tolerances.

orangebox

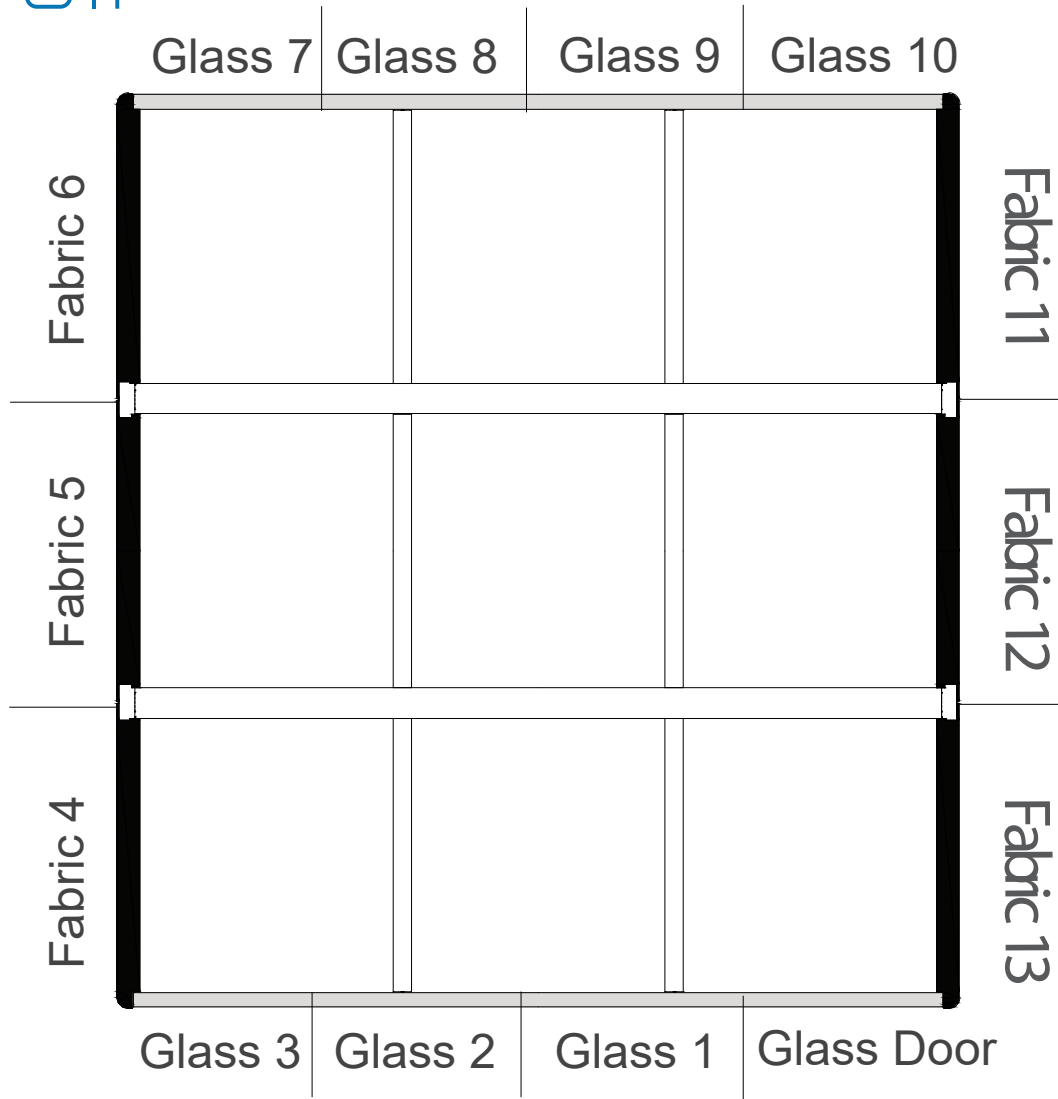

air 29

Glass Door: 1160w x 2189h

Glass 1: 1035w x 2170h

Glass 2: 930w x 2170h

Glass 3: 930w x 2170h

Glass 7: 930w x 2170h

Glass 8: 1035w x 2170h

Glass 9: 1035w x 2170h

Glass 10: 930w x 2170h

Graphic Application Notes:

Dimensions provided are taken from the full glass panel size. Due to the floor level adjustments of the glass, the graphics will have to be cut down to the actual visual size during application on site. We cannot provide the actual visual size as this will vary from pod to pod due to tolerances.

BACK GLASS INSTALLATION

1 CLEAN EDGE OF GLASS WITH ISOPROPANOL WIPES

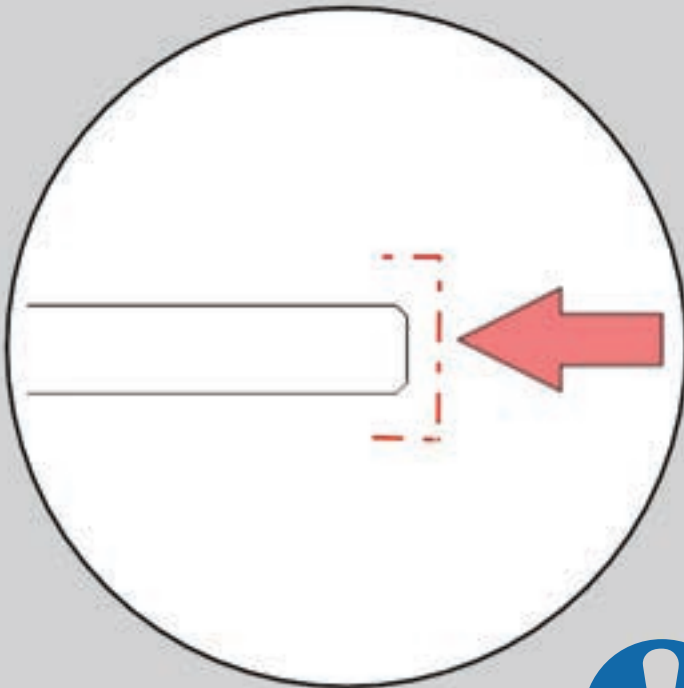

2 REMOVE BONDING TAPE STRIP FROM PLASTIC STRIP

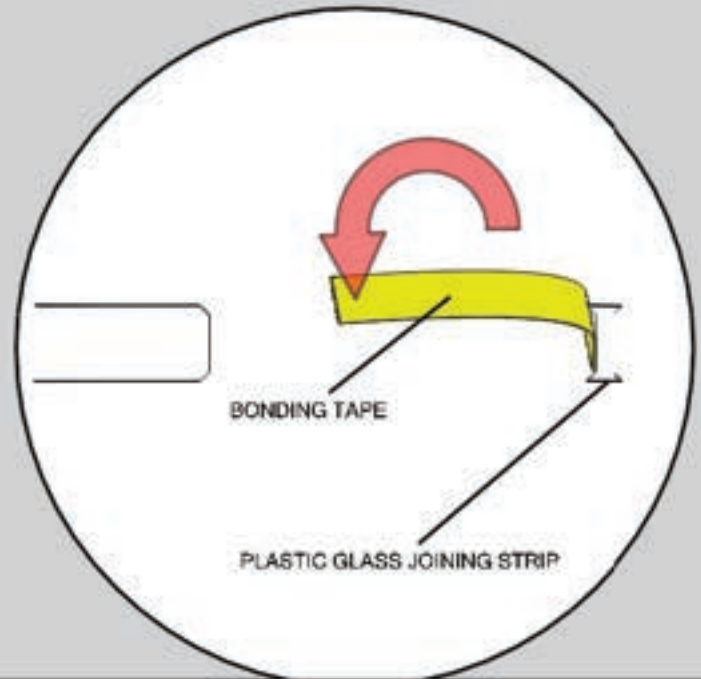

BONDING STRIP GOES BEYOND TOP OF GLASS TO AID WITH PULLING THE STRIPS OUT DURING DISSASSEMBLY

3 CAREFULLY MATCH EDGES OF BONDING STRIP WITH EDGE OF GLASS ENSURING THE GLASS SITS INSIDE THE STRIP AS SHOWN

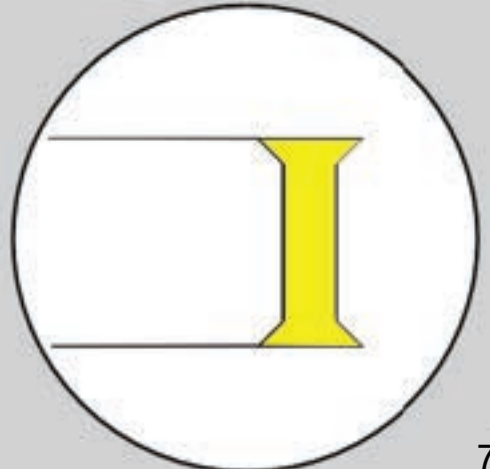
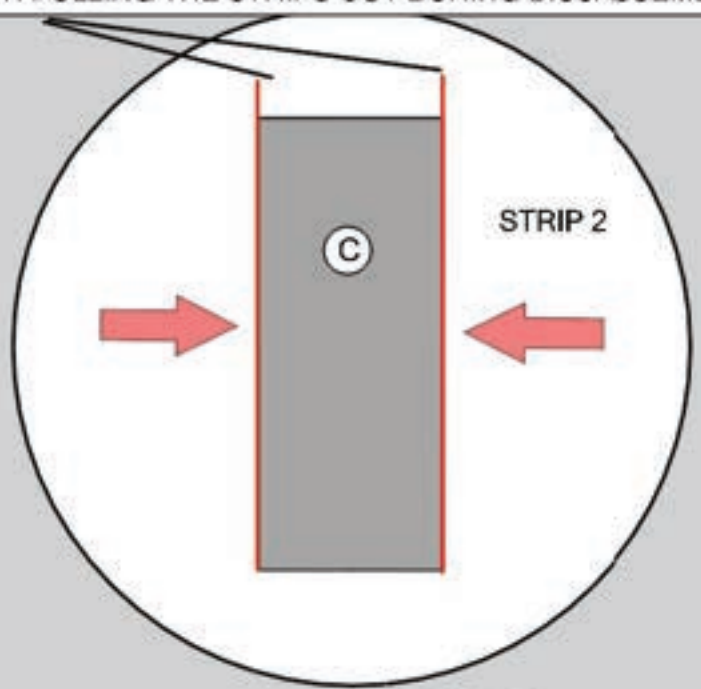
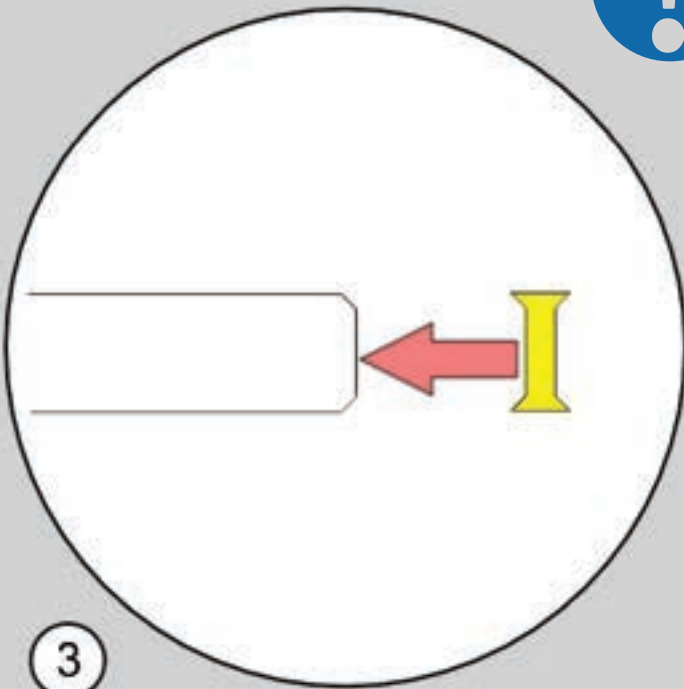

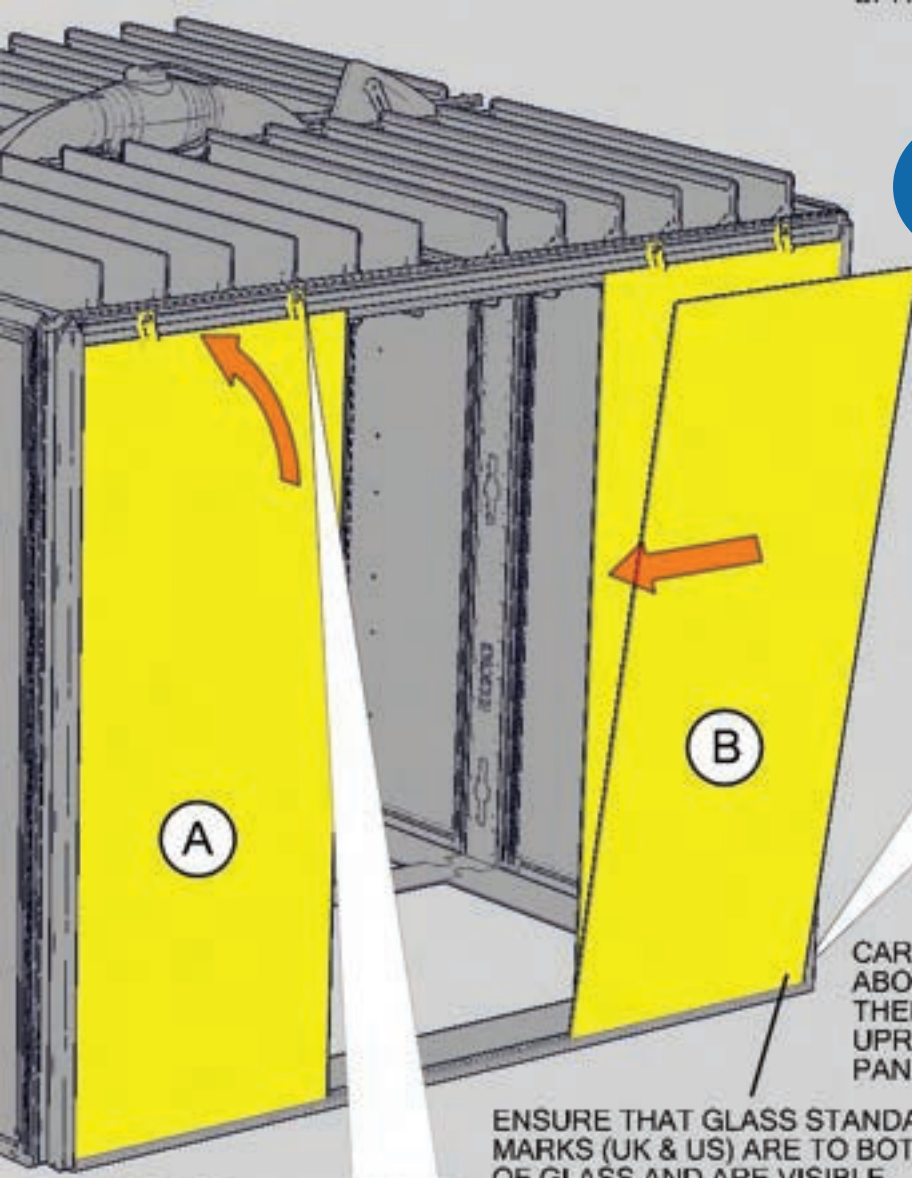

1

CAREFULLY LIFT THE GLASS INTO THE SLOT SHOWN ABOVE AND THEN STAND THE GLASS UP VERTICALLY THEN CAREFULLY SLIDE THE GLASS AS FAR INTO THE UPRIGHT AS POSSIBLE. PANEL A FIRST, PANEL B SECOND

ENSURE THAT GLASS STANDARD MARKS (UK & US) ARE TO BOTTOM OF GLASS AND ARE VISIBLE

BACK OF POD

TORQUE
6NM (4.42 FT-LBF)

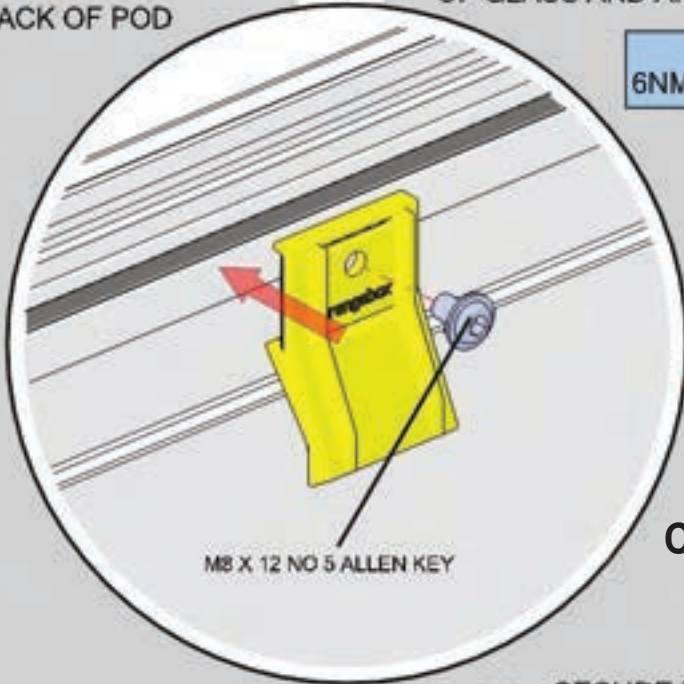

M8 X 12 NO 5 ALLEN KEY

CAUTION:

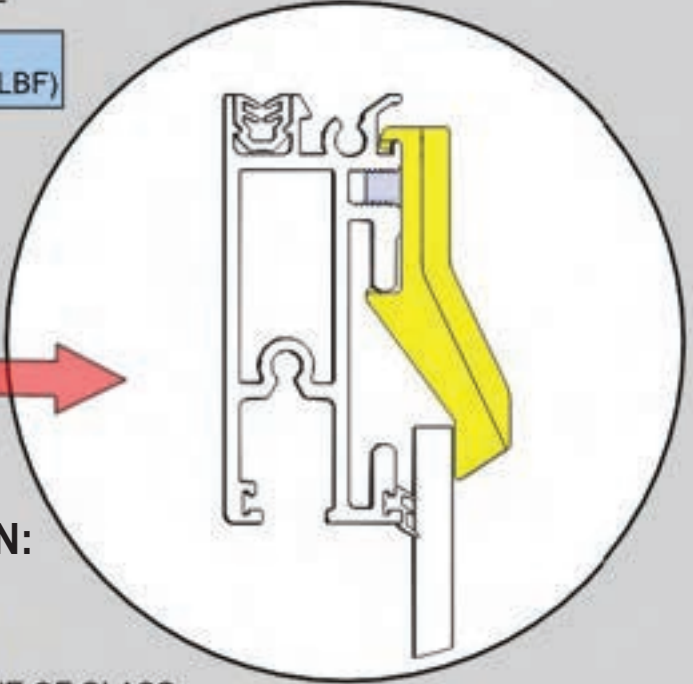

2

SECURE EACH PANE OF GLASS WITH X2 CLAMPS AS SOON AS THE GLASS IS IN POSITION



TWO PERSONS MINIMUM

SEE PAGE 10.13

1

USE THE SUCTION CUPS BOTH SIDES OF THE GLASS TO LIFT PANE C INTO PLACE

2

ENSURE THAT ALL PANES OF GLASS ARE STRAIGHT AGAINST EACH OTHER. USE THE SUCTION CUPS TO LIFT THE GLASS AND ADD PACKERS WHERE NEEDED

3

REMOVE PAPER BACKING FROM ADHESIVE STRIP

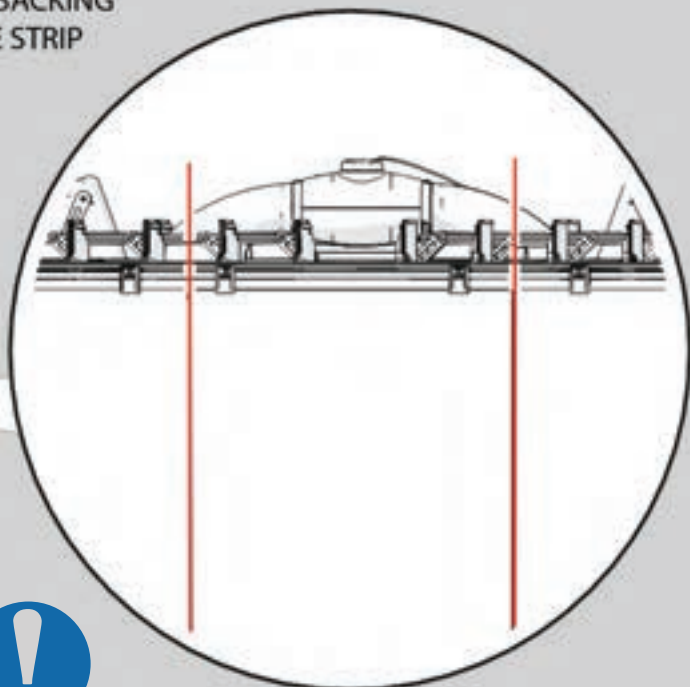
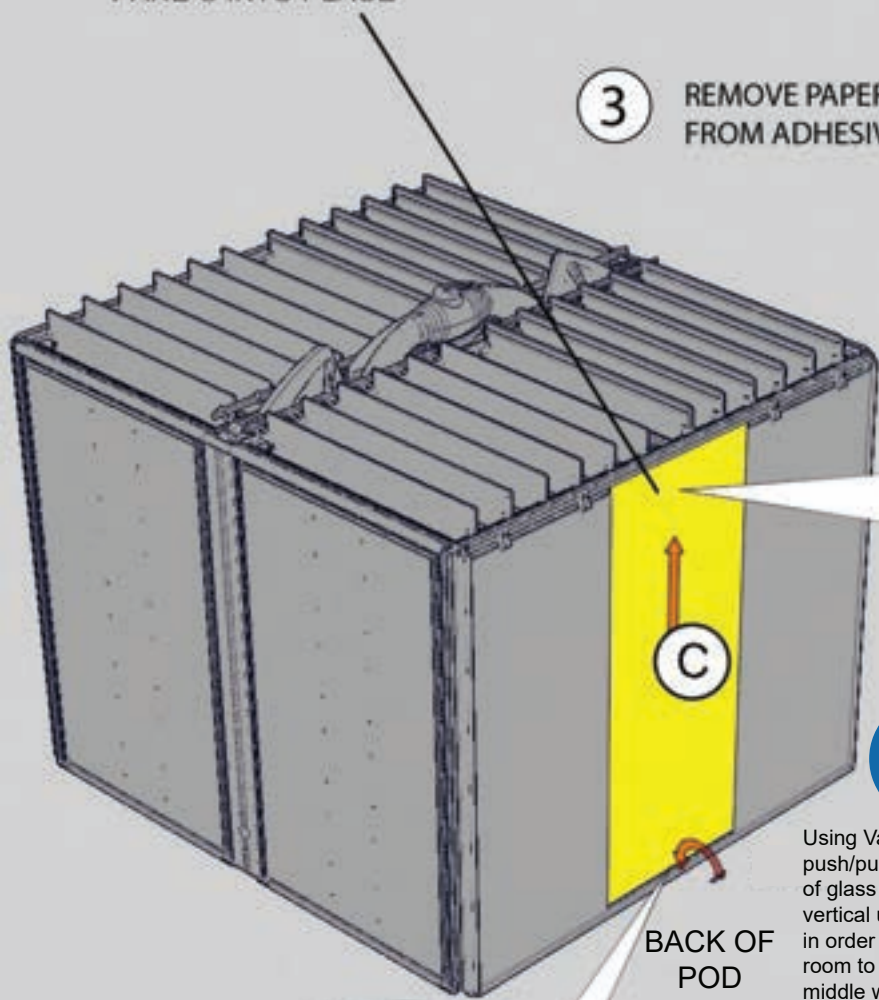

Using Vacuum Suction Cups, push/pull the two outside pieces of glass as far into the corner vertical upright as possible in order to provide enough room to place piece C in the middle without damaging it

BACK OF POD

1MM THICK PACKERS/SHIMS

IF NECESSARY USE PACKERS/SHIMS TO LEVEL THE GLASS

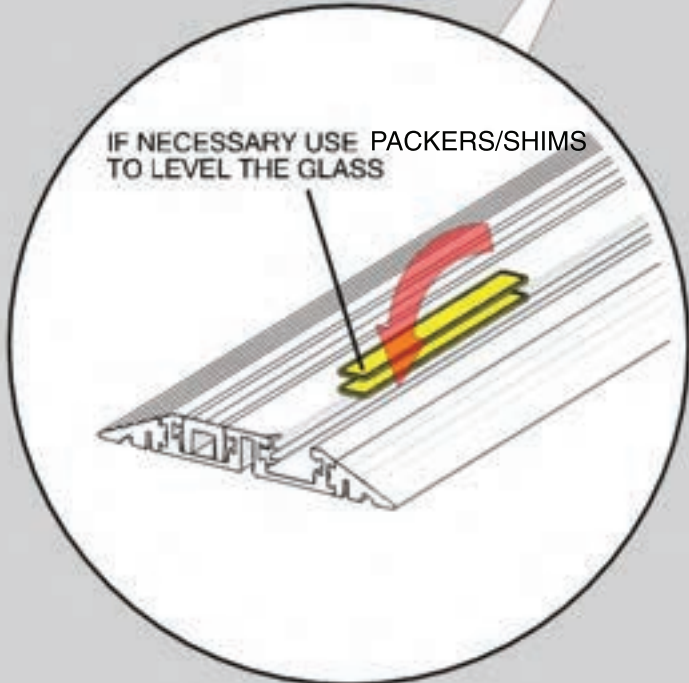

ONLY USE SPECIFIC GLASS PACKERS/SHIMS ISSUED IN INSTALL KIT

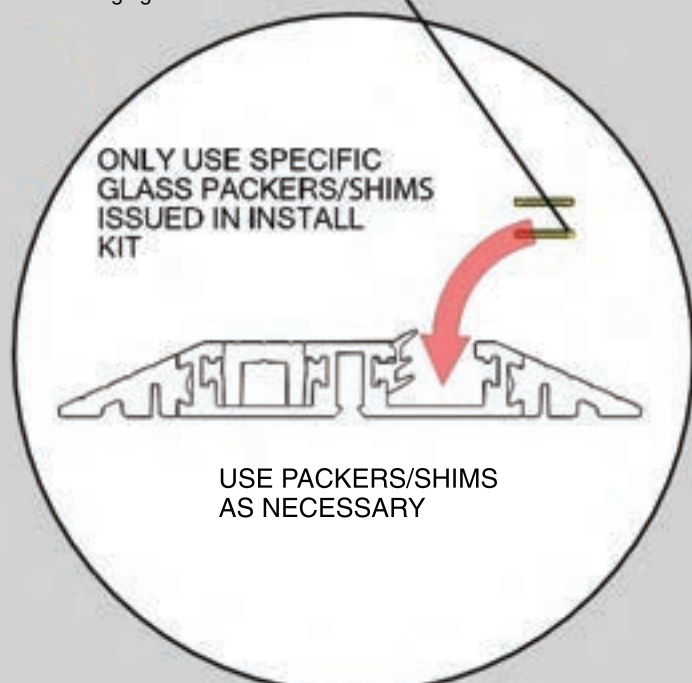

USE PACKERS/SHIMS AS NECESSARY



THREE PERSONS MINIMUM

DO NOT USE METAL PACKERS

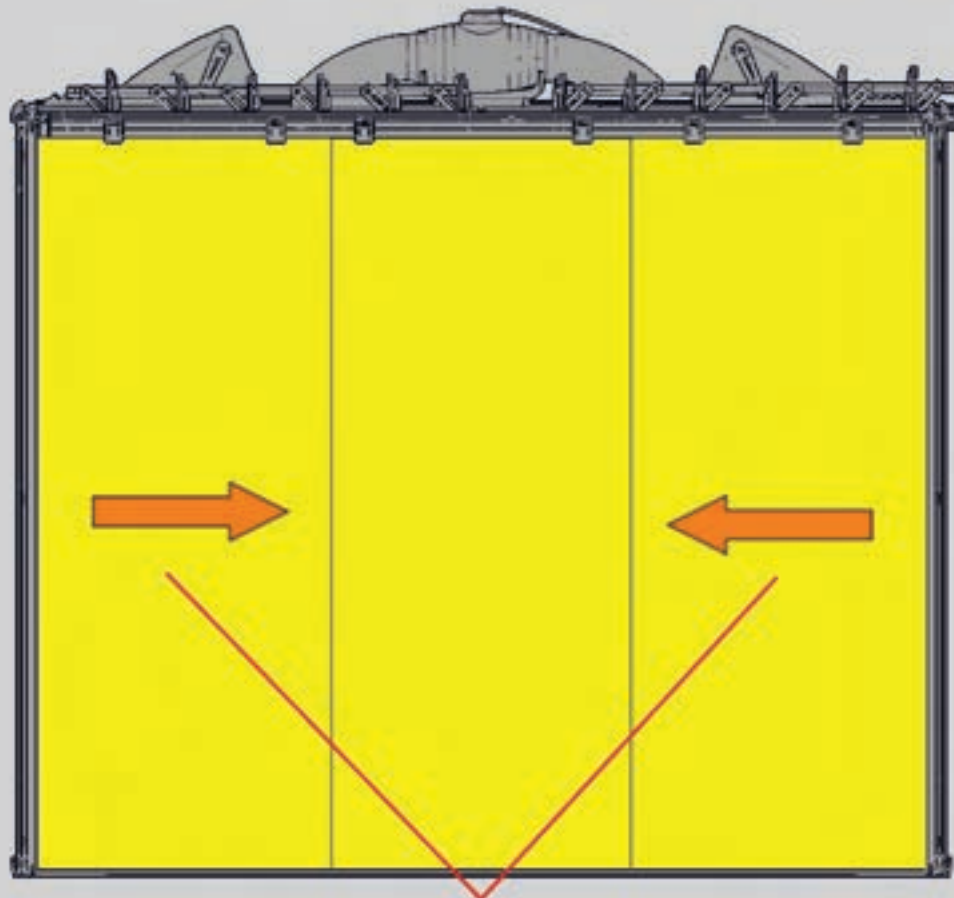

USE A SUCTION CUP ON EACH OF THE OUTSIDE PANES OF GLASS AND PULL TOWARDS THE CENTRAL PANE TO BOND ALL THREE PANES TOGETHER
 ENSURE THAT ALL THREE PANES ARE CENTRAL WITH EQUAL AMOUNT OF GLASS ENGAGING THE UPRIGHTS AT EACH SIDE

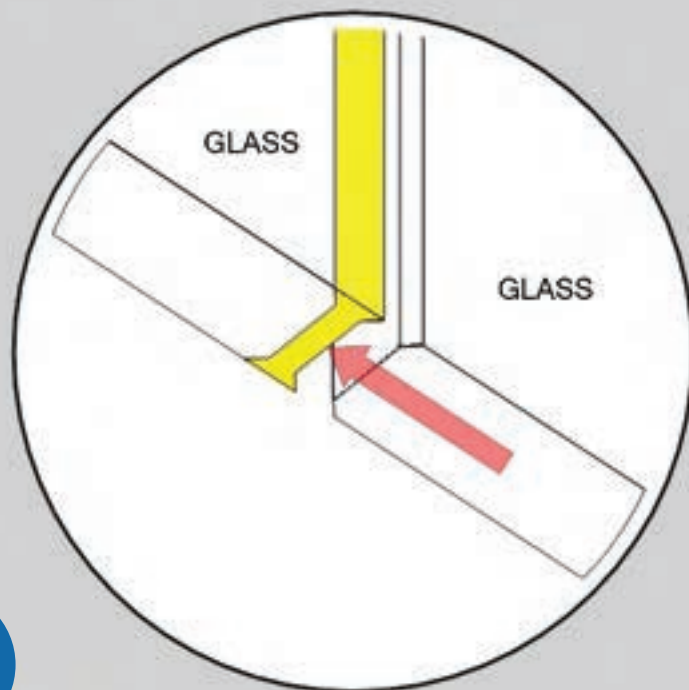
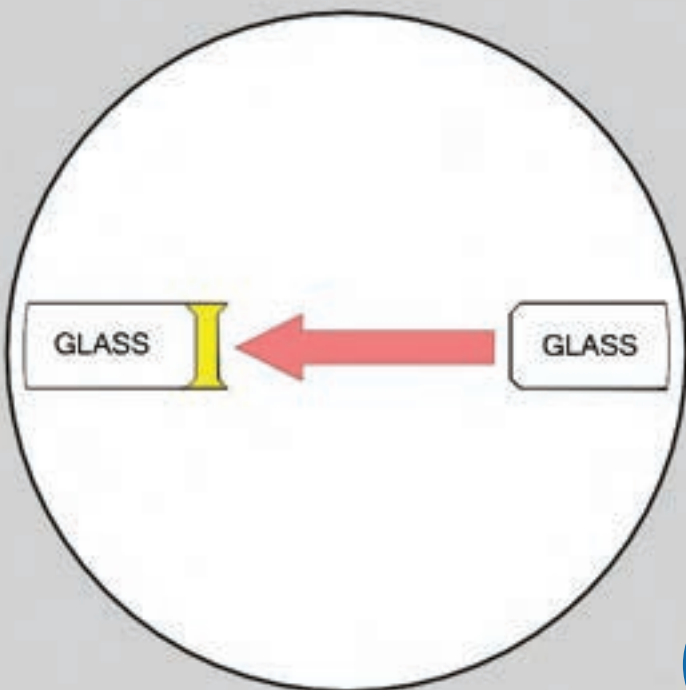

TAKE YOUR TIME ENSURING THE GLASS IS PACKED PERFECTLY LEVEL AND THAT THE GLASS IS PUSHED EXACTLY INTO THE SHAPE OF THE JOINING STRIP TO CREATE A NICE FLUSH SEAL
 IF THE GLASS WILL NOT ALIGN, FLIP THE GLASS ON LONG EDGE (TO KEEP GLASS CERTIFICATION MARKING ON BOTTOM) TO CREATE MORE FAVORABLE CONDITIONS FOR ALIGNMENT



TWO PERSONS MINIMUM

1 USE THE SEALING ROLLER TOOL TO SEAL THE GLASS ON THE OUTSIDE OF THE POD ONLY. USE THE OPPOSITE END OF THE TOOL TO PUSH THE SEAL IN AND THEN USE THE WHEEL TO SMOOTH INTO POSITION



WHEN USING THE SEAL BE CAREFUL NOT TO STRETCH IT DURING ROLLING/ WIPING IT IN. IT WILL SHRINK OVER TIME IF STRETCHED!

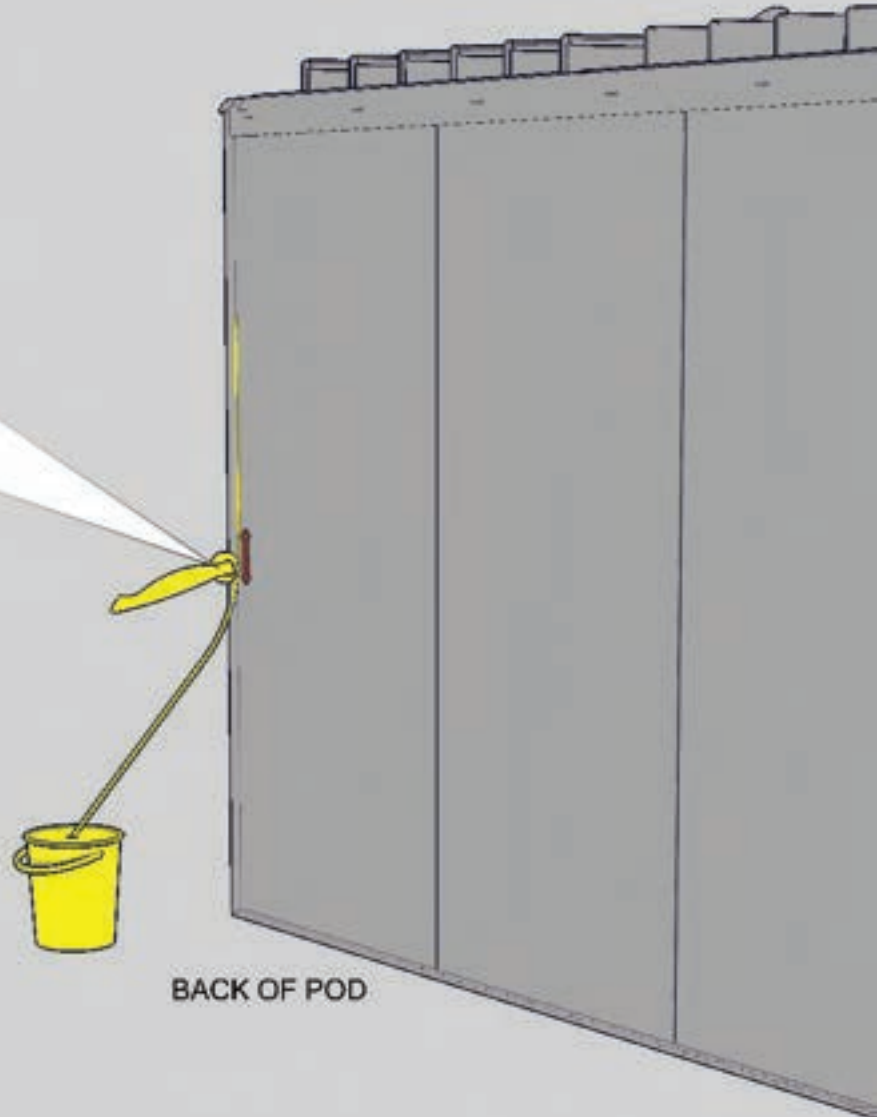
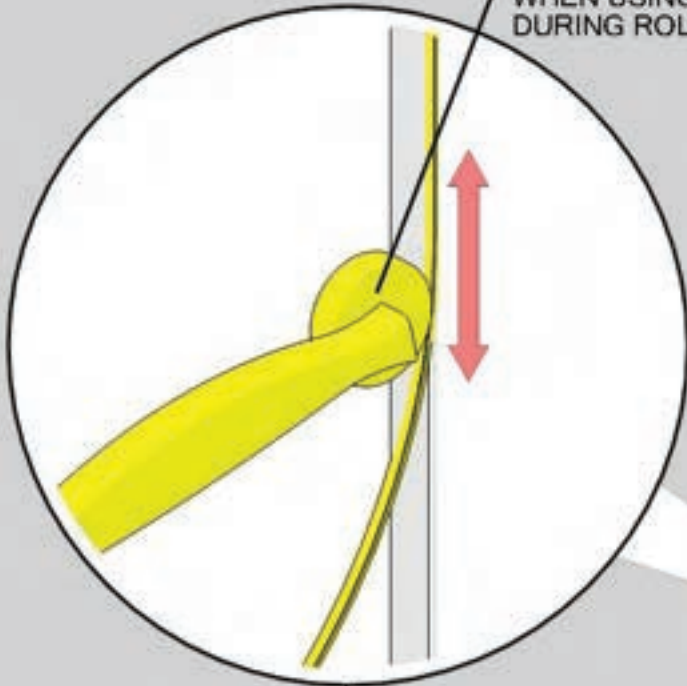

BACK OF POD

NOTE WHICH WAY AROUND SEAL PUSHES INTO PROFILE

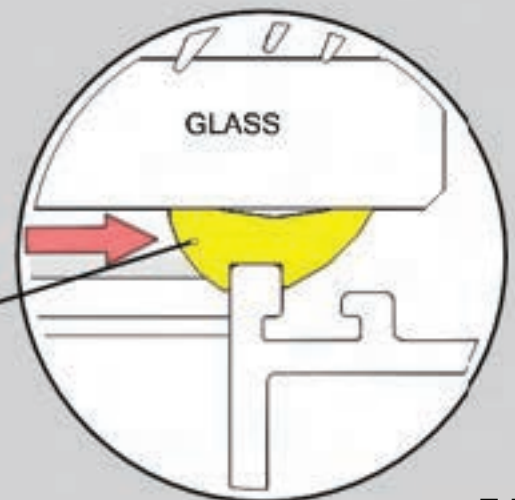

ONE PERSON MINIMUM

SEE PAGE 10.8 + 10.14

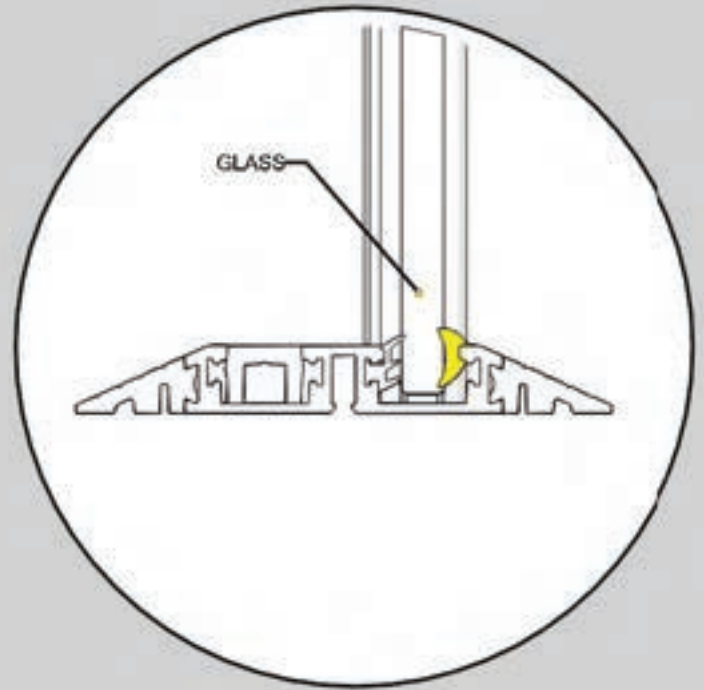
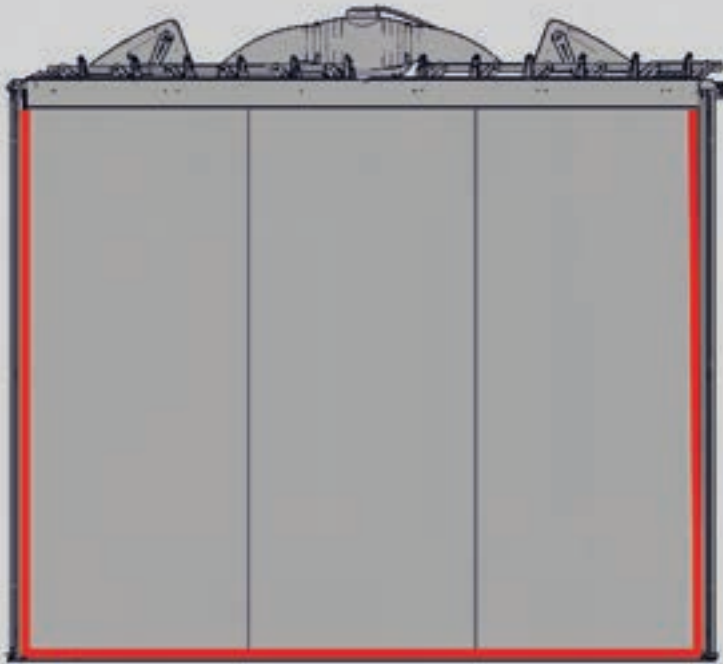

LOCATION OF EXTERNAL SEAL
ALONG BOTTOM DOOR TRACK

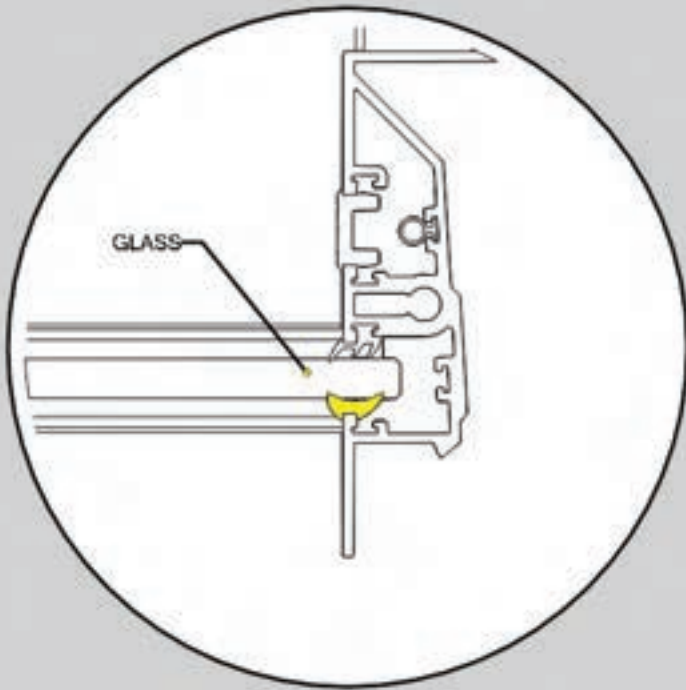

LOCATION OF EXTERNAL SEAL
ON VERTICAL GLASS FRAMES

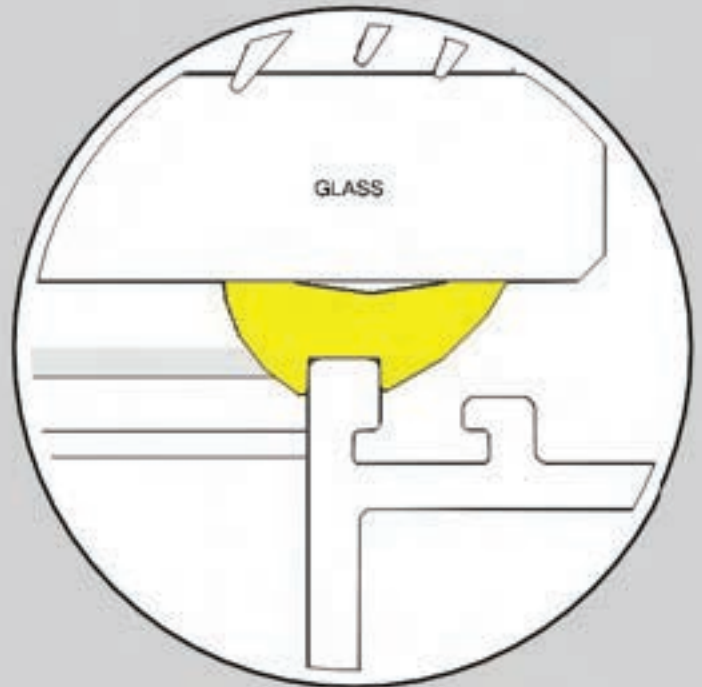

NOTE POSITION OF SEAL
IN PROFILE



ONE PERSON MINIMUM

SEE PAGE 10.8 + 10.14

USE GLASS CLAMPS WITH RUBBER PAD TO CREATE SECURE LOCATION AT JOINS IN GLASS. BE SURE GLASS CLAMPS GRIP BOTH GLASS PANELS ON EITHER SIDE OF THE JOINT.



THIS IS A CRITICAL SECURITY DETAIL FOR GLASS RETENTION

TORQUE
6NM (4.42 FT-LBF)

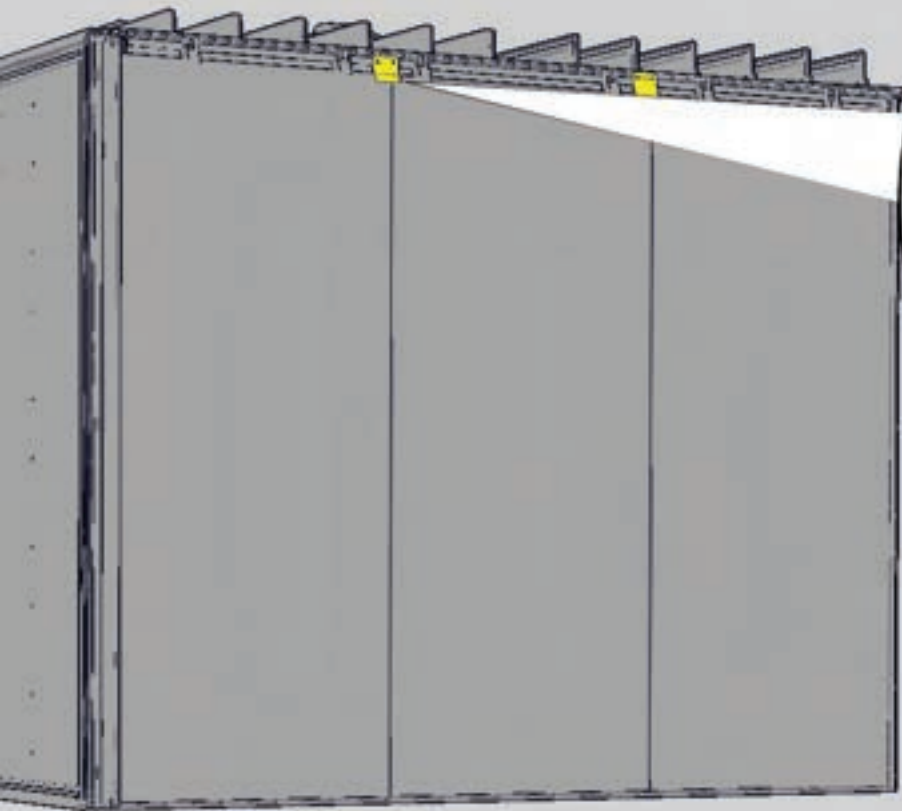

BACK OF POD

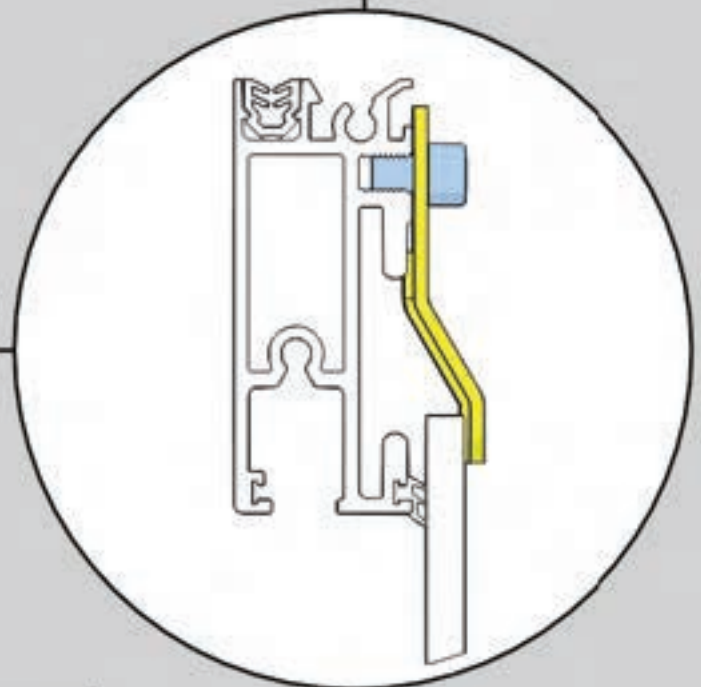
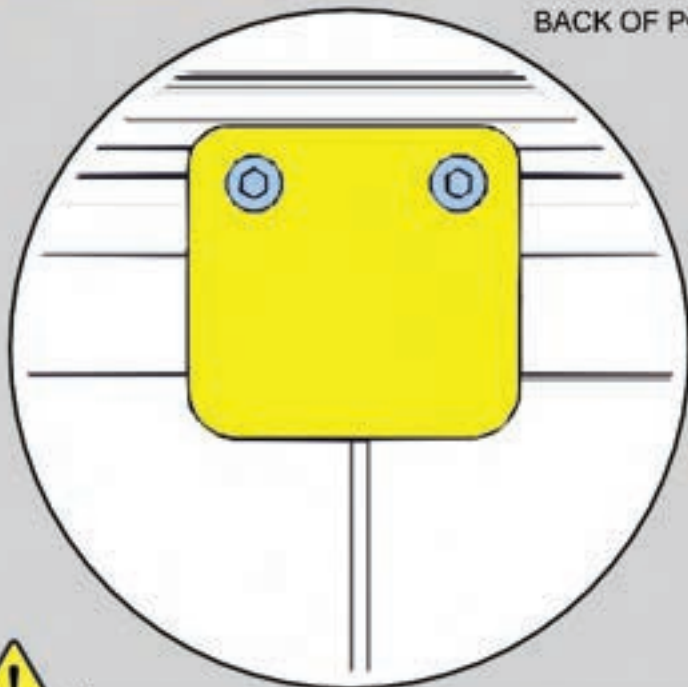
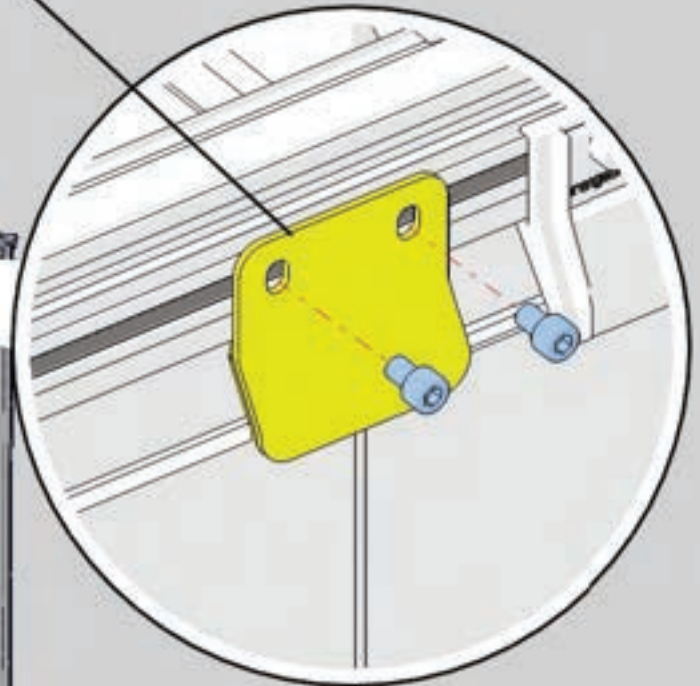

GLASS CLAMP SHARED ACROSS BOTH PIECES OF GLASS



ONE PERSON MINIMUM

FRONT GLASS INSTALLATION

1 CLEAN EDGE OF GLASS WITH ISOPROPANOL WIPES

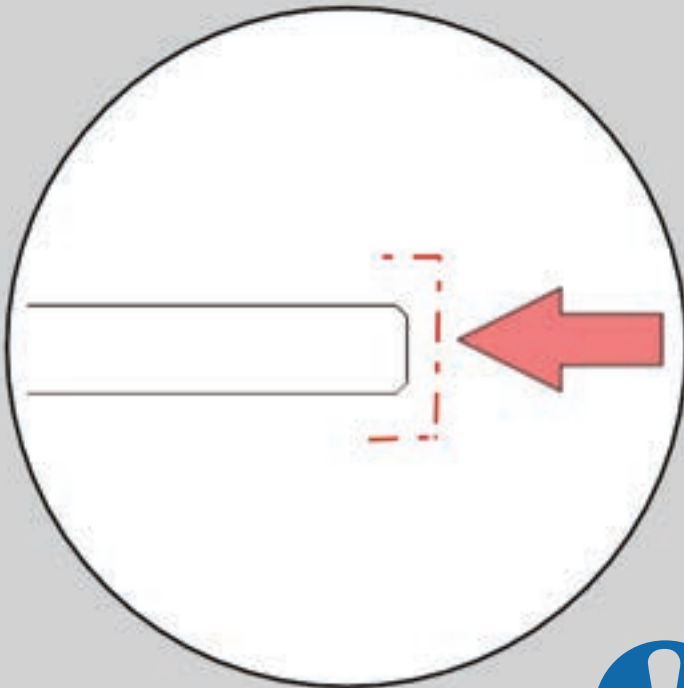

2 REMOVE BONDING TAPE STRIP FROM PLASTIC STRIP

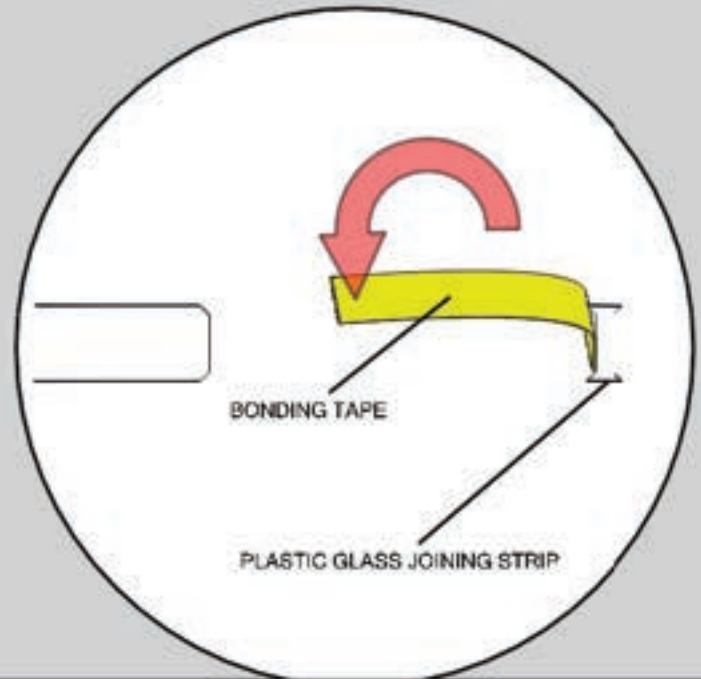

BONDING STRIP GOES BEYOND TOP OF GLASS TO AID WITH PULLING THE STRIPS OUT DURING DISSASSEMBLY

3 CAREFULLY MATCH EDGES OF BONDING STRIP WITH EDGE OF GLASS ENSURING THE GLASS SITS INSIDE THE STRIP AS SHOWN

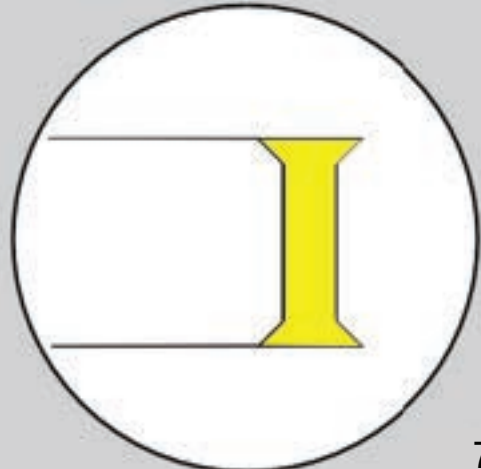
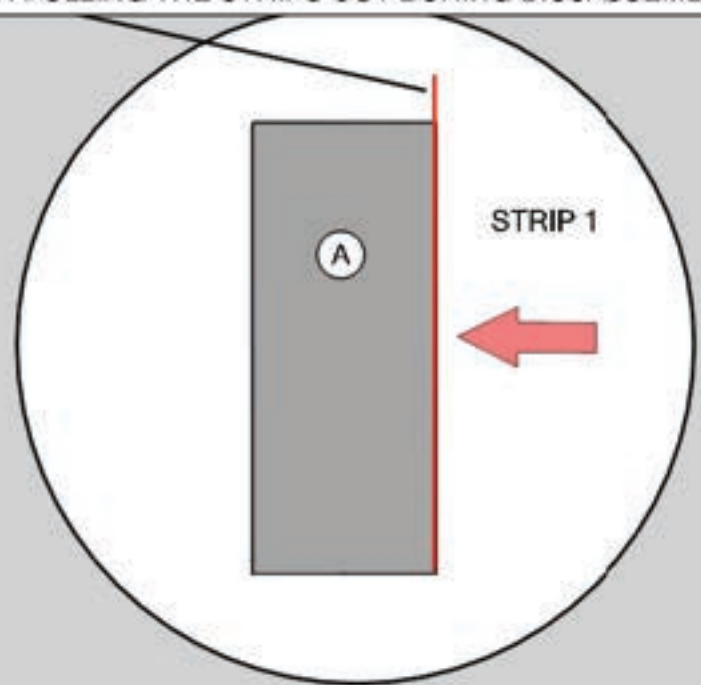
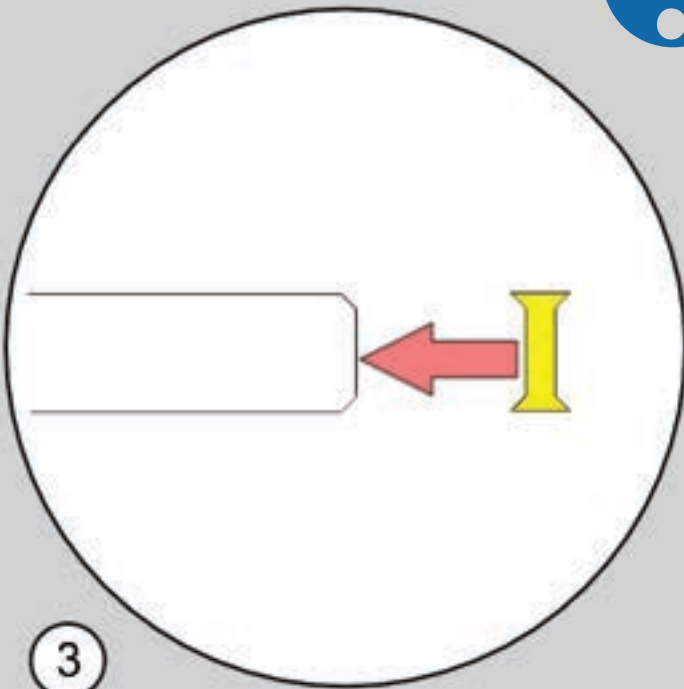

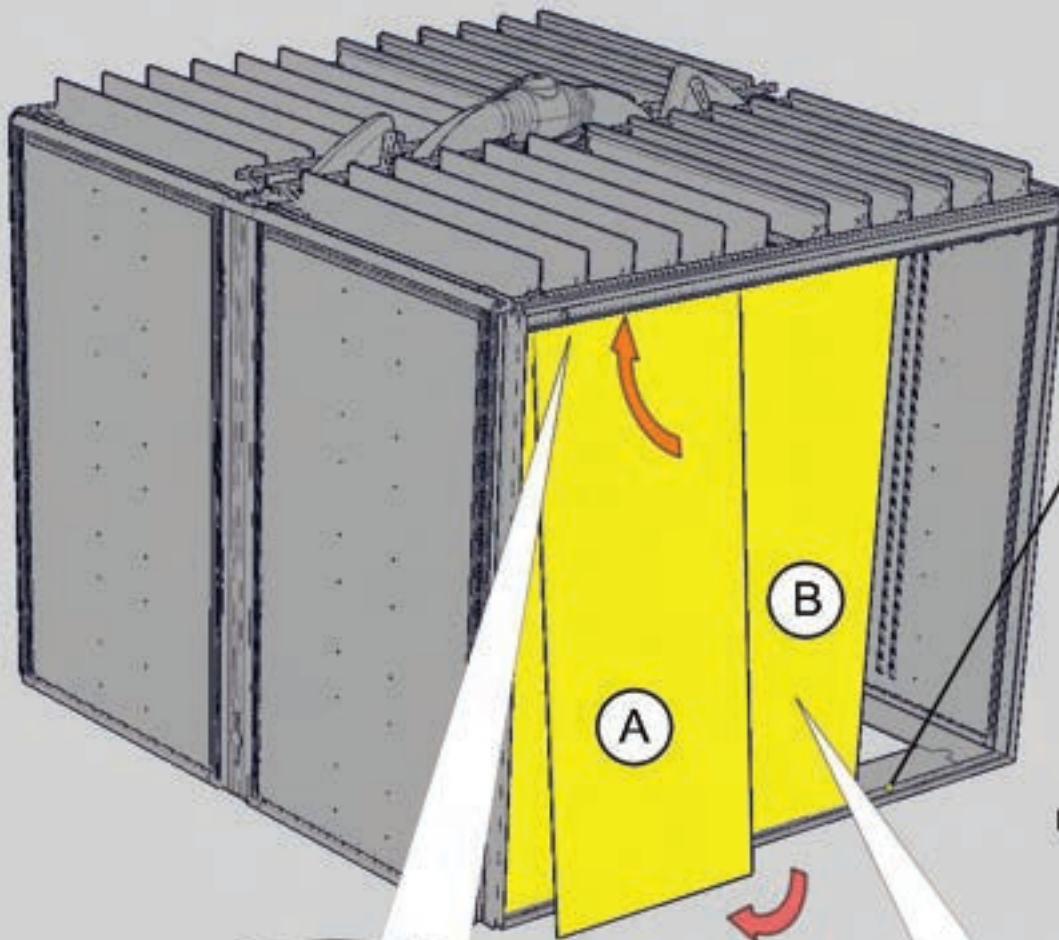

TIP: WHEN INSTALLING GLASS 'B' PULL BACK THE RUBBER FINISHING SEAL AT THE BOTTOM TO HELP THE GLASS LOCATE. THIS SEAL MAY NEED TRIMMING ONCE GLASS IS IN.

FRONT OF POD (DOOR)

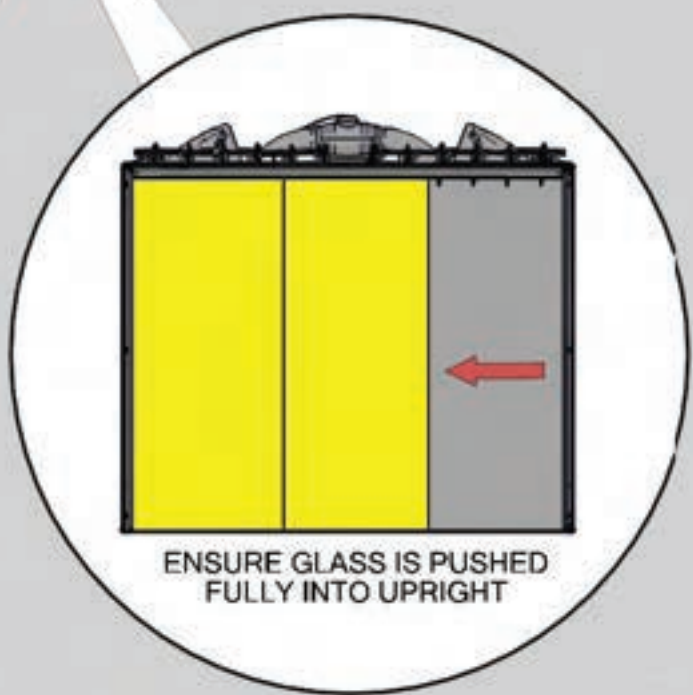
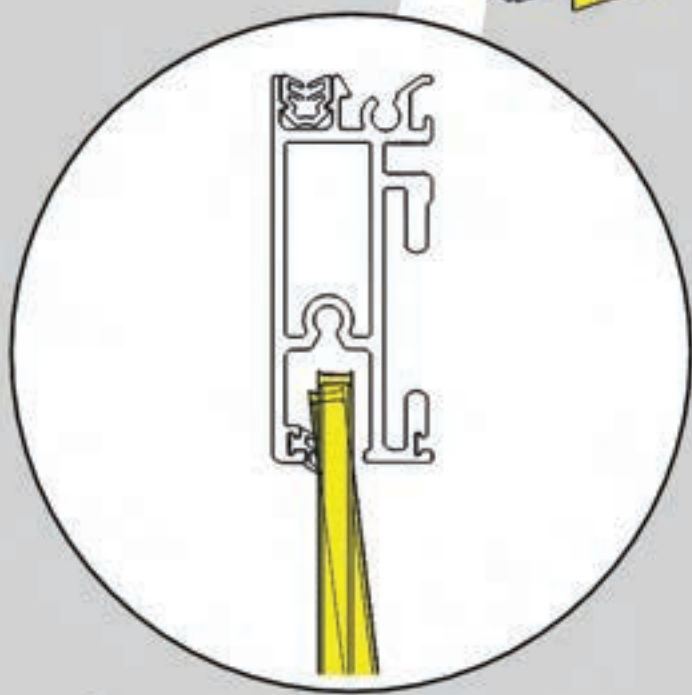

ENSURE GLASS IS PUSHED FULLY INTO UPRIGHT

1 CAREFULLY LIFT THE GLASS INTO THE SLOT AS SHOWN ABOVE AND THEN SWING INTO THE CORRESPONDING BOTTOM CHANNEL. THEN CAREFULLY SLIDE THE GLASS AS FAR INTO THE UPRIGHT AS POSSIBLE. PANEL A FIRST, PANEL B SECOND

LOOSEN THE TOP CROSSBAR FIXINGS AND GENTLY TAP THE CROSSBAR UP TO ALLOW A LITTLE MORE ROOM FOR THE GLASS TO LIFT IN. BE CAREFUL NOT TO KNOCK THE TOP CROSSBAR OFF!! RISK OF DAMAGE TO GLASS AND INJURY



CAUTION:



THREE PERSONS MINIMUM

SEE PAGE 10.13

1

USE THE RUBBER PACKING PADS (IN MULTIPLES IF NECESSARY) TO PACK AGAINST THE GLASS AND THE TOP DOOR TRACK TO PREVENT IT FROM SAGGING DOWN. THE MEASUREMENT AT THE UPRIGHT MUST BE CONSISTANT ALL THE WAY ALONG



THIS PACKING BETWEEN THE GLASS AND CROSSBAR IS ESSENTIAL TO ENSURE THE DOOR RUNS STRAIGHT AND SMOOTH

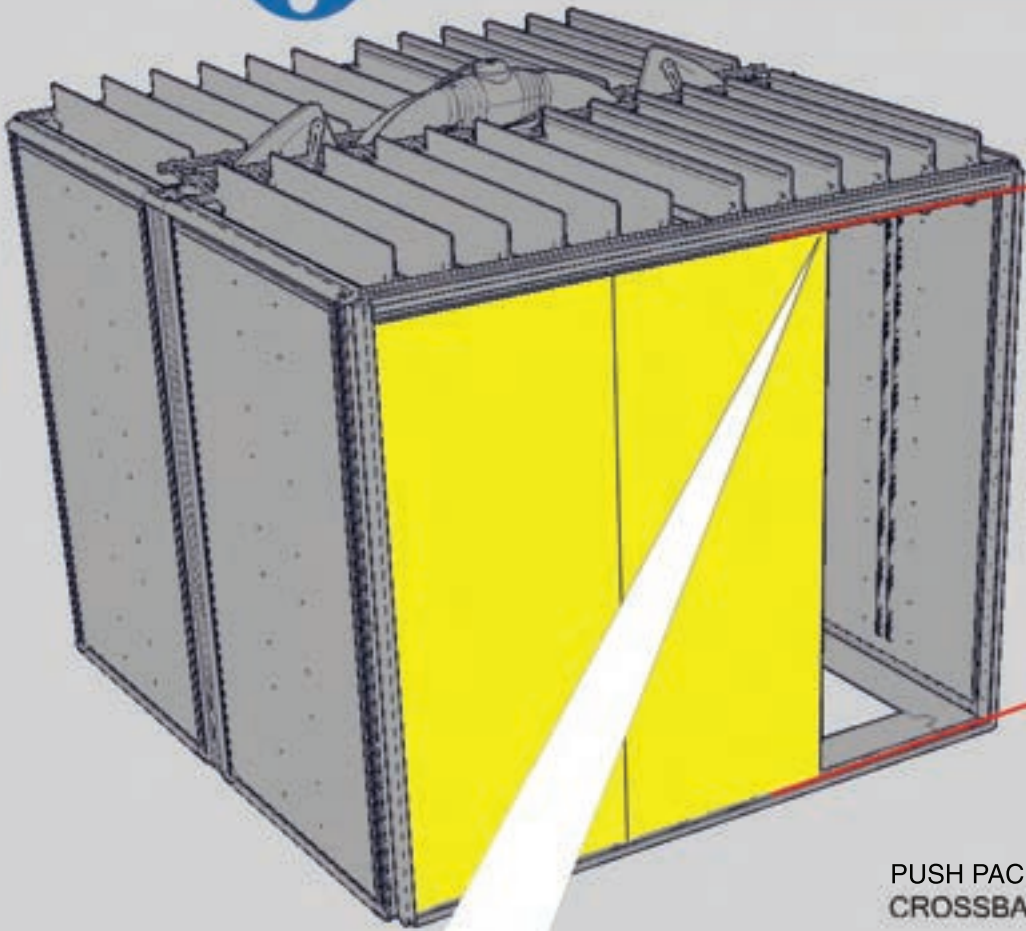

2140MM / 84"(FROM BOTTOM FACE OF TOP CROSSBAR TO TOP FACE OF BOTTOM CROSSBAR)

PUSH PACKERS/SHIMS PADS UP INTO CROSSBAR ON TOP OF GLASS CORNER

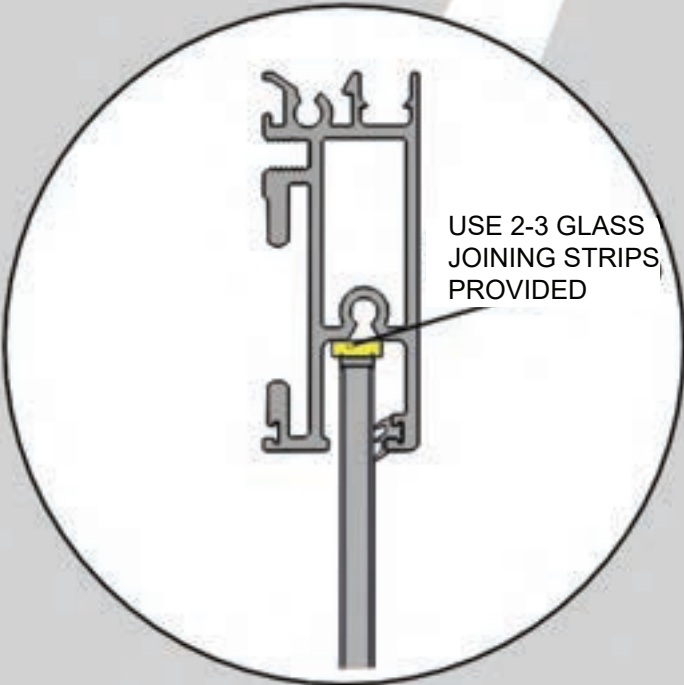

USE 2-3 GLASS JOINING STRIPS PROVIDED

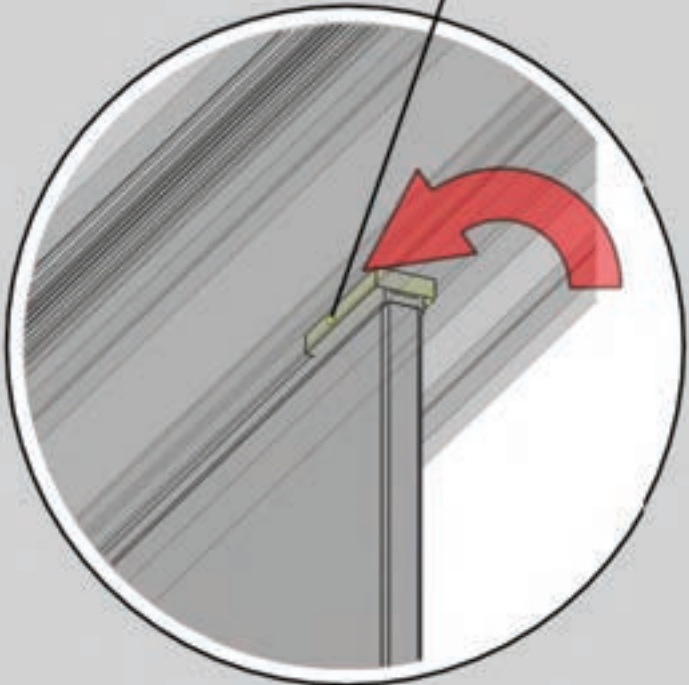

ONE PERSON MINIMUM

SEE PAGE 10.8

1

USE THE SUCTION CUPS BOTH SIDES OF THE GLASS TO LIFT THE PANE UP FOR GLASS PACKERS/SHIMS

2

ENSURE THAT BOTH PANELS OF GLASS ARE STRAIGHT AGAINST EACH OTHER. USE ADDITIONAL GLASS PACKERS/SHIMS WHERE NEEDED TO LEVEL

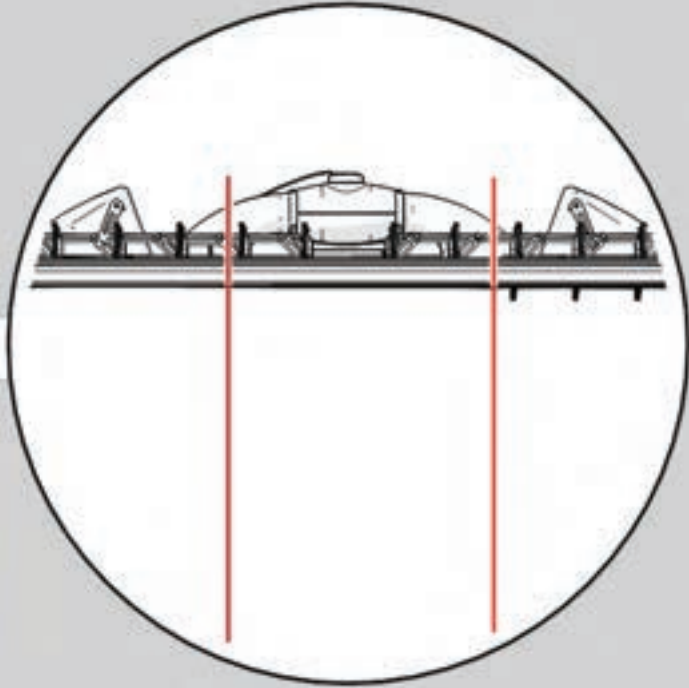
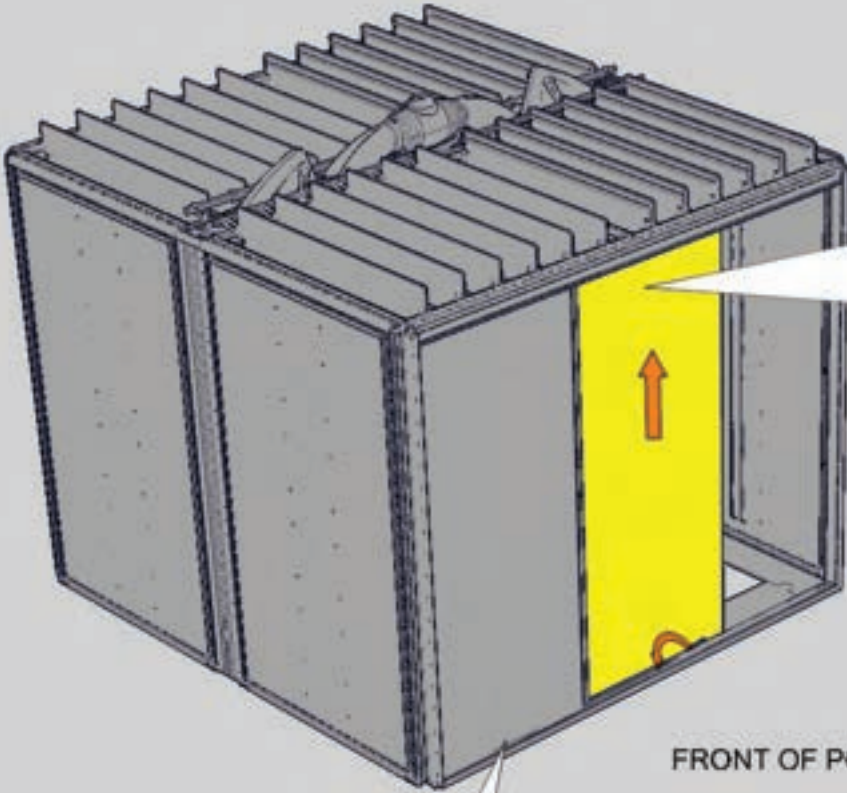

FRONT OF POD (DOOR)

IF NECESSARY USE PACKERS/SHIMS TO LEVEL THE GLASS

1MM THICK PACKERS/SHIMS

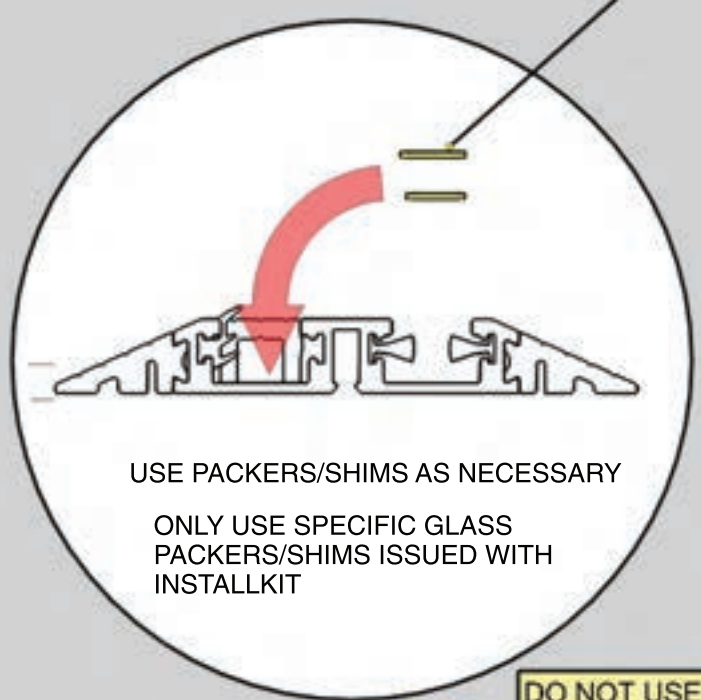
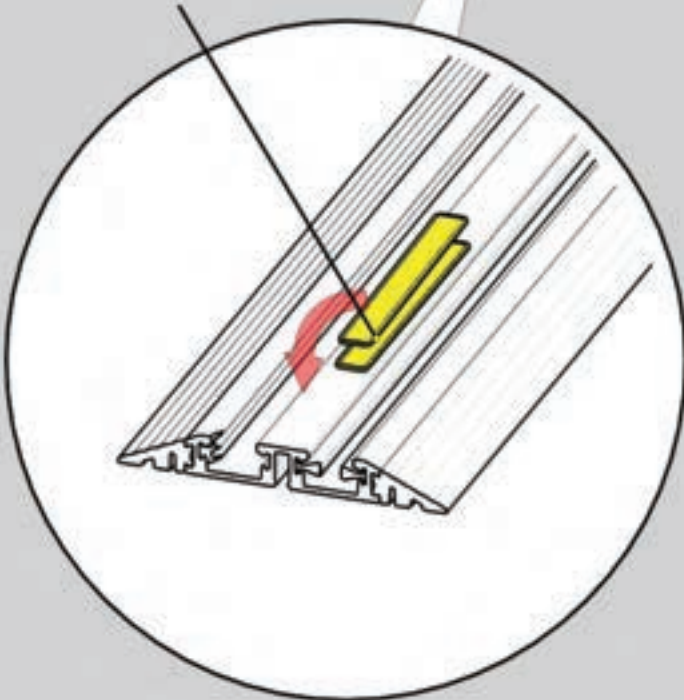

USE PACKERS/SHIMS AS NECESSARY

ONLY USE SPECIFIC GLASS PACKERS/SHIMS ISSUED WITH INSTALLKIT

DO NOT USE METAL PACKERS



THREE PERSONS MINIMUM



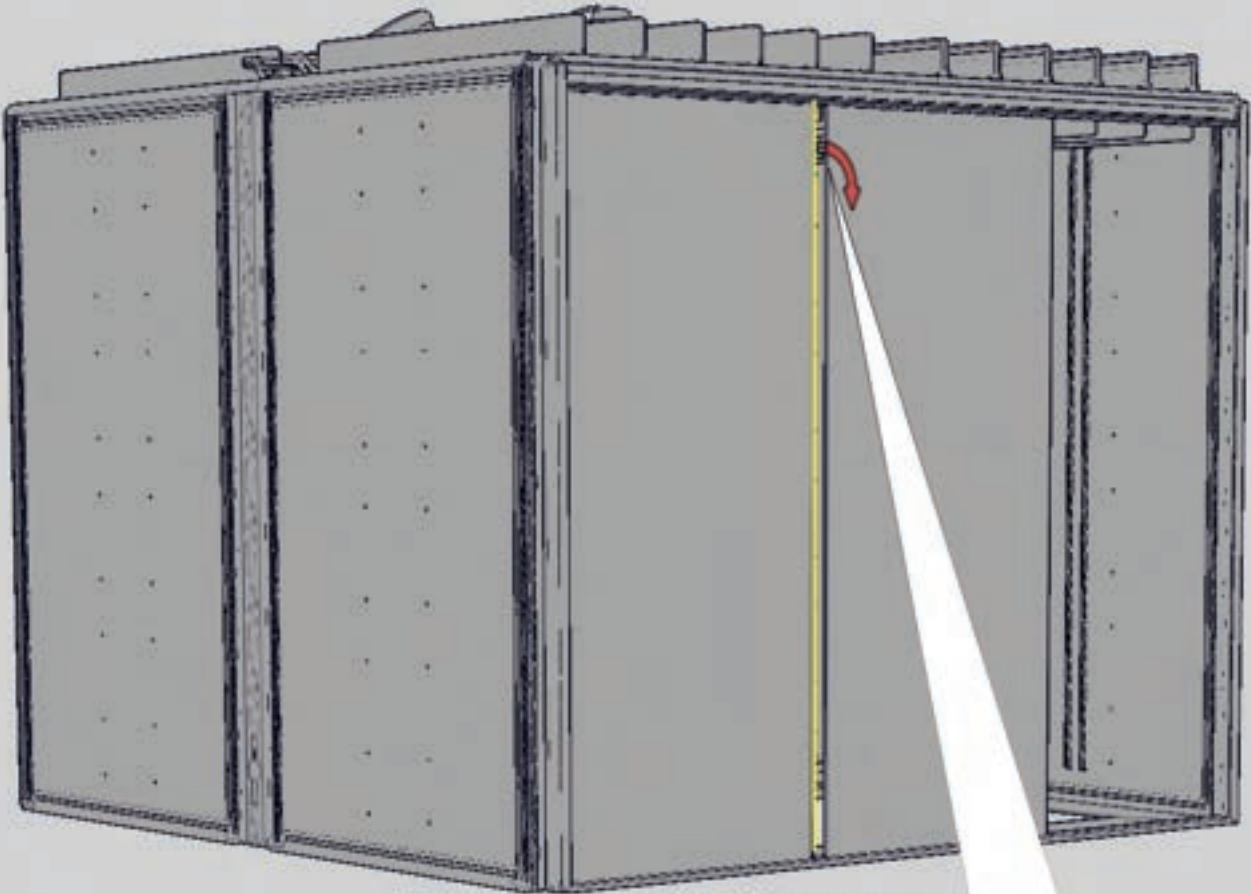

FRONT OF POD (DOOR)

REPEAT THIS PROCESS ON PREVIOUS PAGE
FOR ALL BONDING STRIPS



ONE PERSON MINIMUM

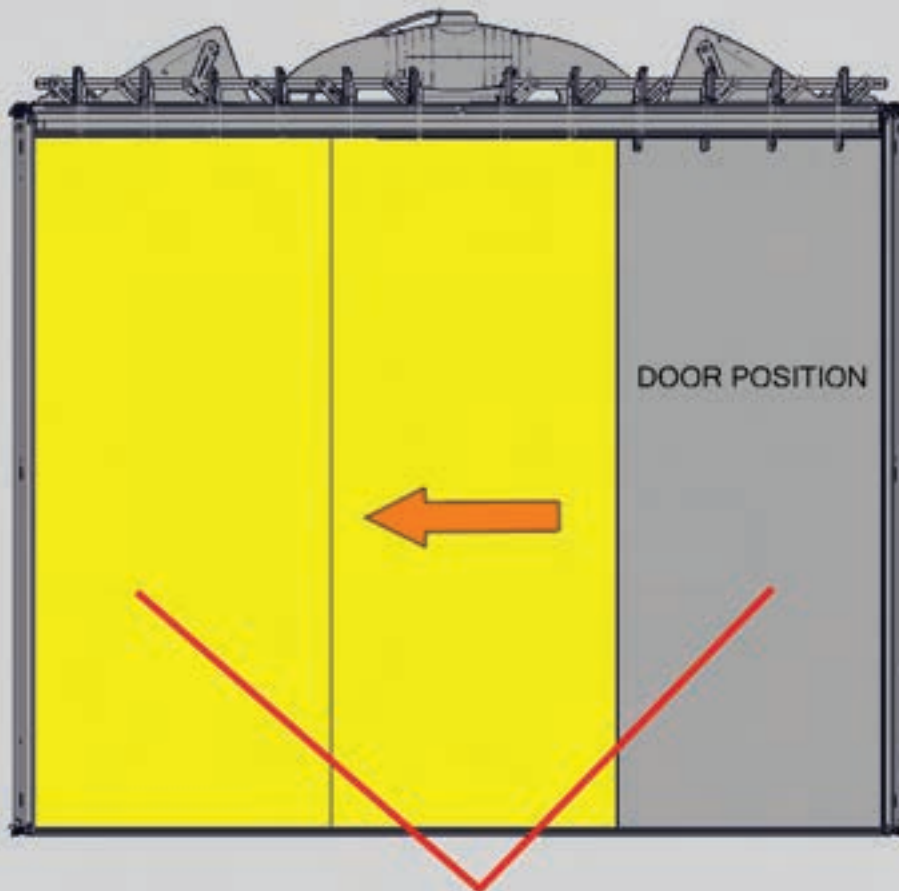

USE A SUCTION CUP ON EACH OF THE OUTSIDE PANES OF GLASS AND PULL BOTH GENTLY IN THE SAME DIRECTION. THIS WILL ENSURE THE PANES ARE FULLY LOCATED INTO THE UPRIGHT AND ARE COMPRESSED TOGETHER

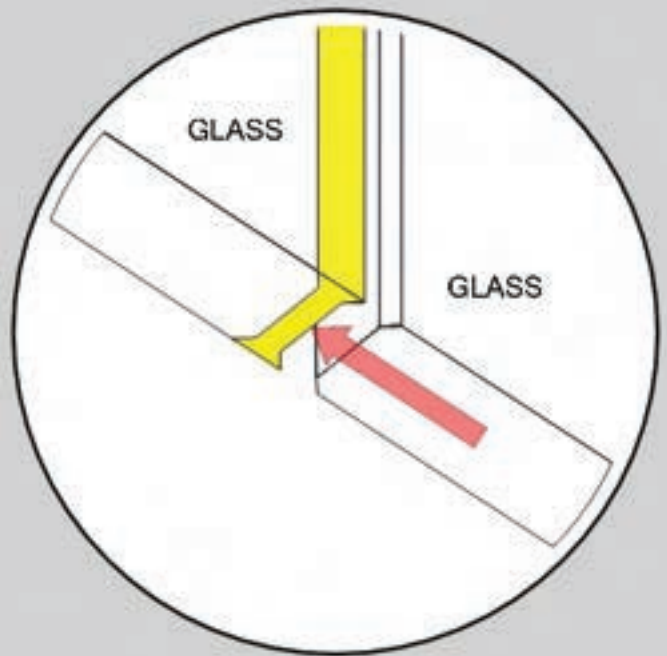
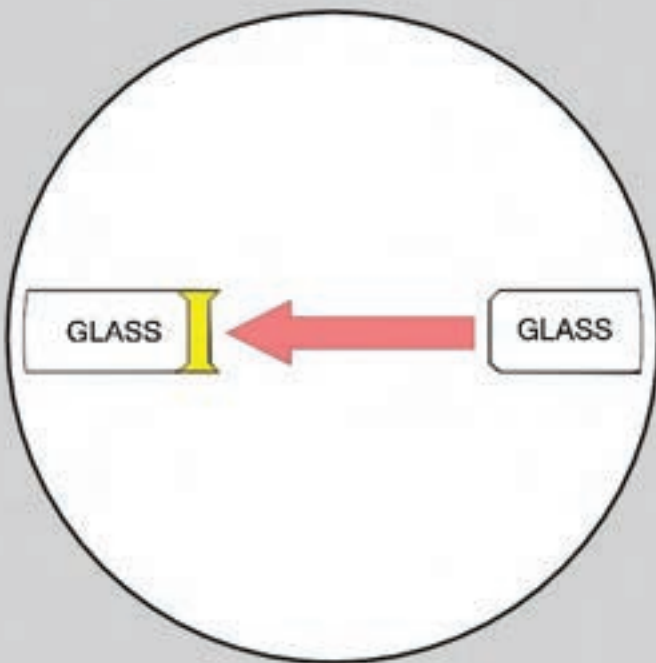

TAKE YOUR TIME ENSURING THE GLASS IS PACKED PERFECTLY LEVEL AND THAT THE GLASS IS PUSHED EXACTLY INTO THE SHAPE OF THE JOINING STRAP TO CREATE A NICE FLUSH LEVEL



THREE PERSONS MINIMUM

1

USE THE SEALING ROLLER TOOL TO SEAL THE GLASS ON THE OUTSIDE OF THE POD ONLY. USE THE OPPOSITE END OF THE TOOL TO PUSH THE SEAL IN AND THEN USE THE WHEEL TO SMOOTH INTO POSITION. IDEALLY THE TOP OF THE GLASS GETS SEALED FIRST, WHILE A SECOND PERSON PUSHES GLASS IN AND UPWARDS UNTIL THE SEAL TAKES HOLD. BEGINNING WITH THE UPRIGHT INSTEAD OF THE TOP COULD CAUSE GAPS TO APPEAR.



WHEN USING THE SEAL BE CAREFUL NOT TO STRETCH IT DURING ROLLING / WIPING IT IN. IT WILL SHRINK OVER TIME IF STRETCHED

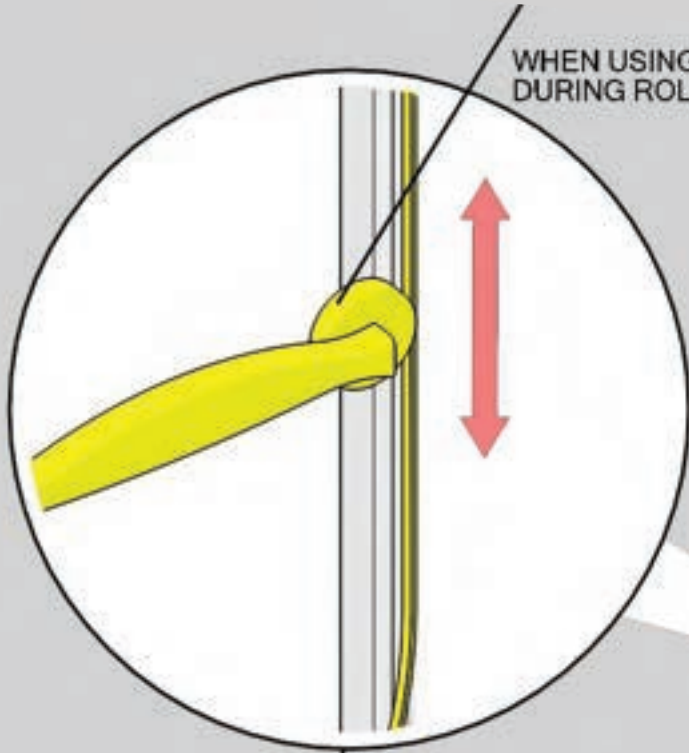

FRONT OF POD (DOOR)

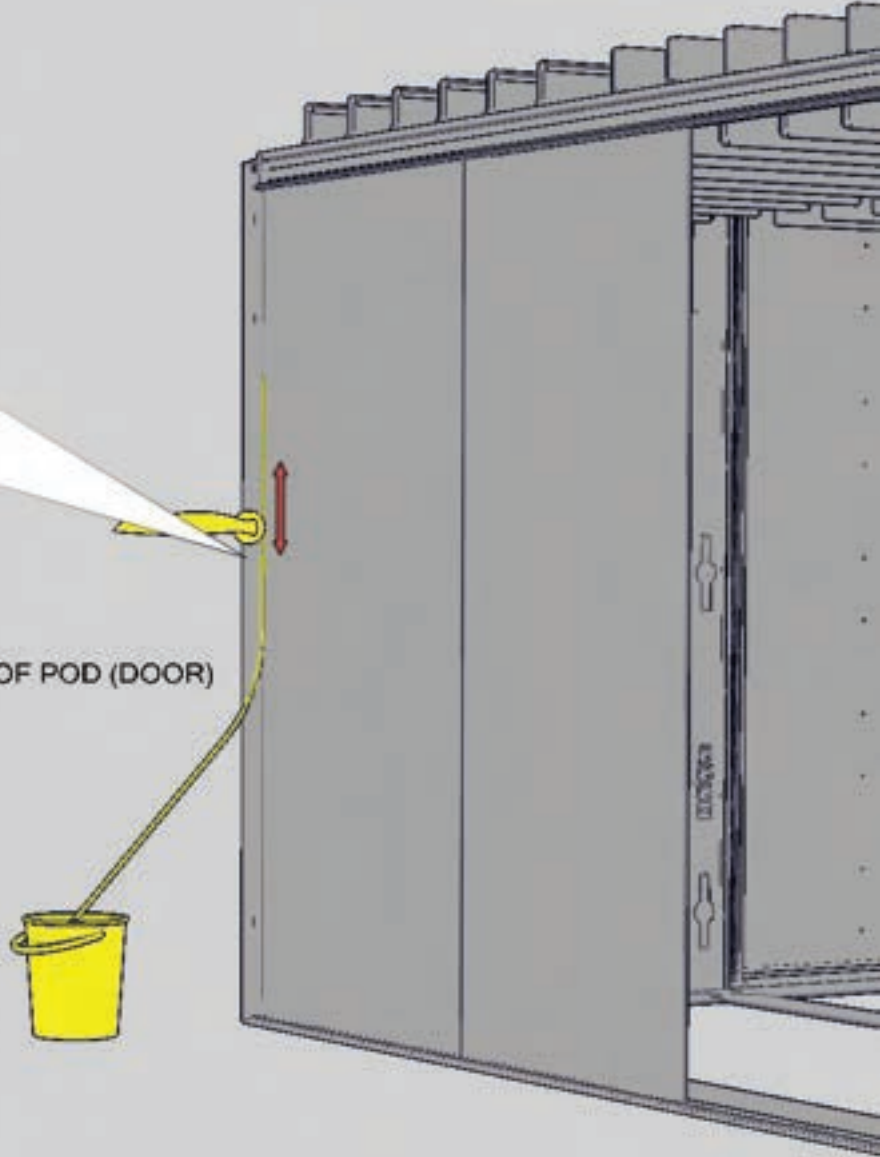

NOTE WHICH WAY AROUND SEAL PUSHES INTO PROFILE

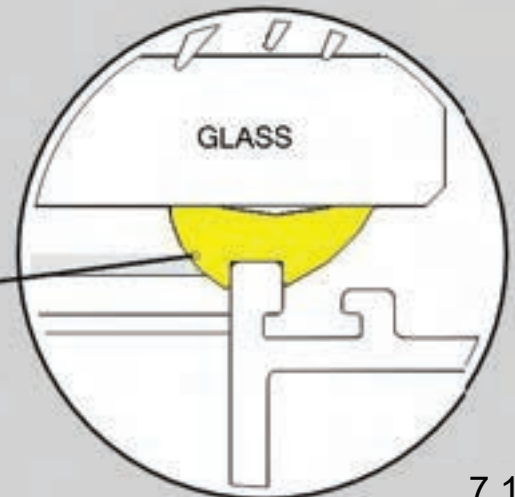

THREE PERSONS MINIMUM

SEE PAGE 10.8 + 10.14

LOCATION OF EXTERNAL SEAL ALONG TOP DOOR TRACK

RED LINE INDICATES WHERE TO SEAL OUTSIDE OF POD

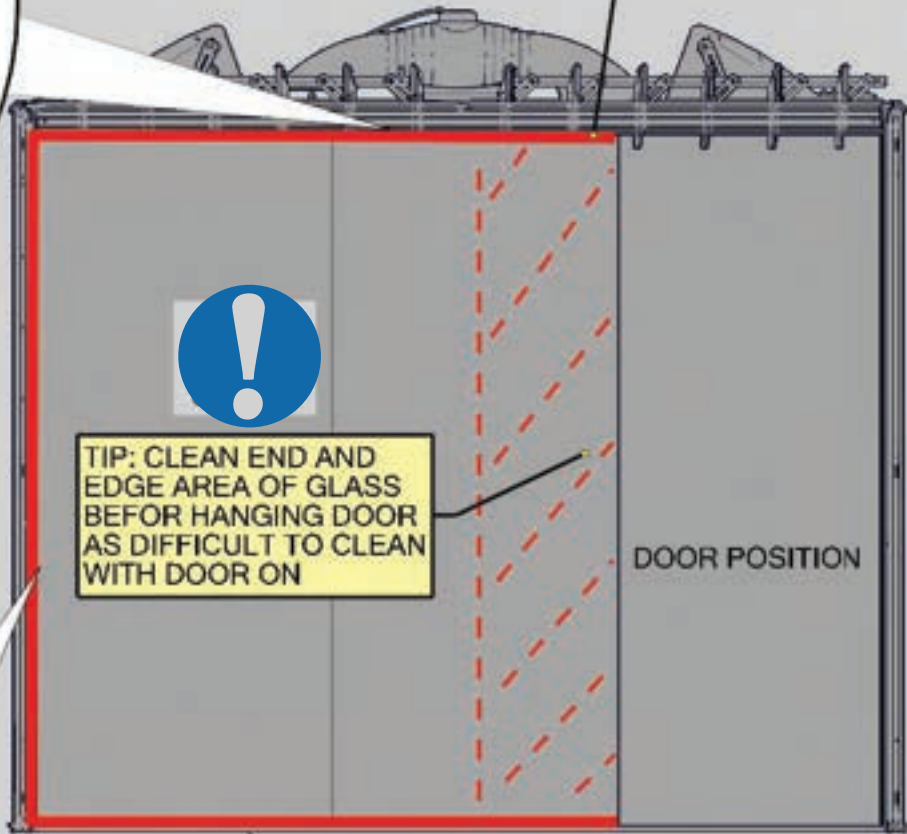
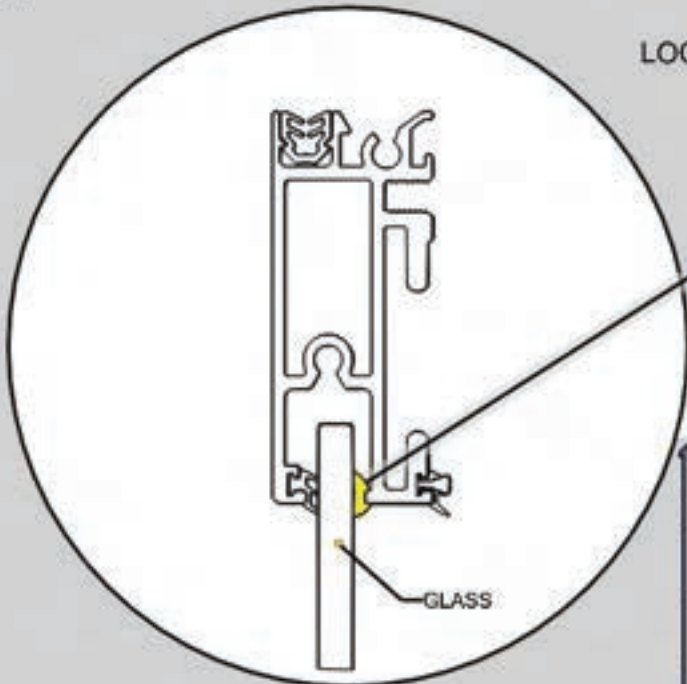

TIP: CLEAN END AND EDGE AREA OF GLASS BEFORE HANGING DOOR AS DIFFICULT TO CLEAN WITH DOOR ON

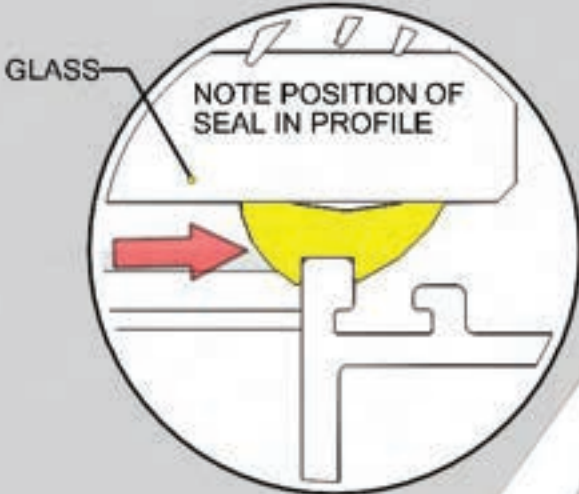

FRONT OF POD (DOOR)

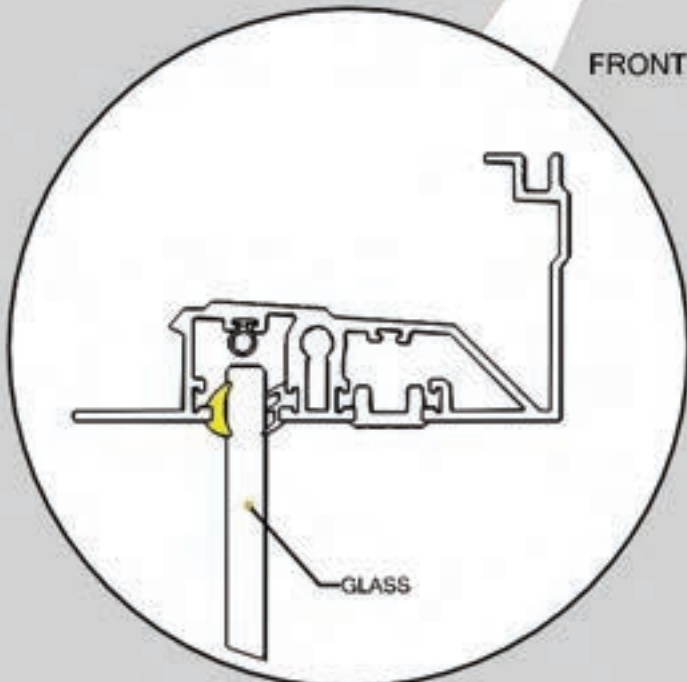

LOCATION OF EXTERNAL SEAL ON VERTICAL FRAME SEALS

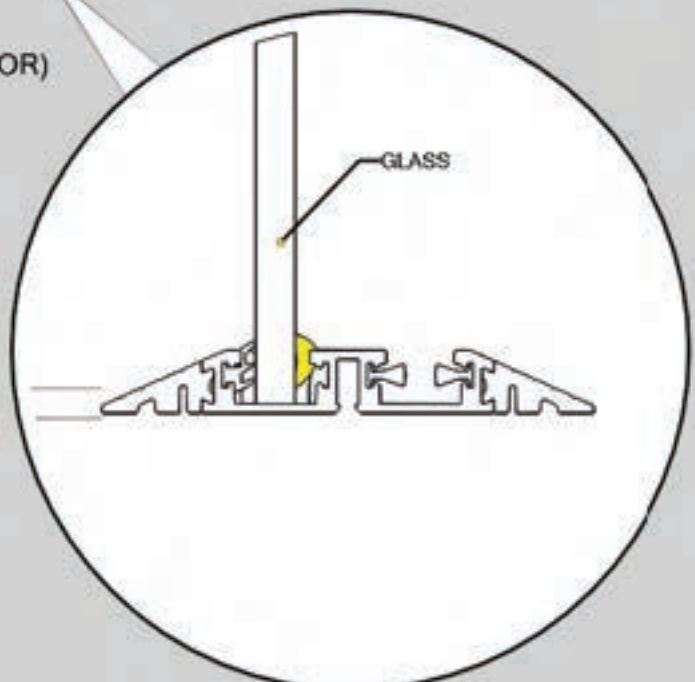

LOCATION OF EXTERNAL SEAL ALONG BOTTOM DOOR TRACK



ONE PERSON MINIMUM

SEE PAGE 10.8 + 10.14

Assembly sequence

Glass door



* NO UNAUTHORISED PERSONNEL PERMITTED TO PARTICIPATE IN ASSEMBLY (ORANGEBOX CERTIFIED PERSONNEL ONLY)

*APPROPRIATE PPE MUST BE WORN AT ALL TIMES DURING ASSEMBLY OF ORANGEBOX PRODUCTS

*PART ASSEMBLED PODS MAY NOT BE LEFT UNATTENDED UNLESS STRUCTURALLY SOUND

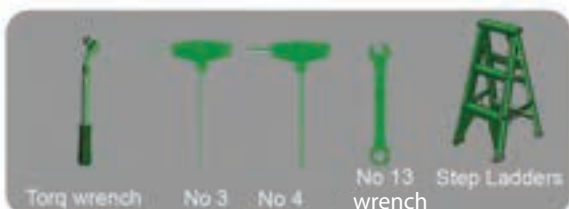

M8 X 25 X3

TORQUE
14NM {10.32FT-LBF}

TIGHTEN X3 FIXINGS

TORQUE WRENCH

ENSURE THAT ALL WHEELS ARE
ADJUSTED TO SAME LEVEL
BEFORE LIFTING ONTO TRACK

NOTE: HAND TIGHTEN
FIXINGS EVENLY TO
AVOID PINCHPOINTS

14NM TORQUE SETTING

NOTE WHERE DOOR HANDLE HOLE POSITIONS
ARE WHEN INSTALLING RUNNERS.
STANDARD RIGHT TO LEFT OPENING DOOR SHOWN



TWO PERSONS MINIMUM

SEE PAGE 10.11 - N10.12

PRESS MALE AND FEMALE COMPONENTS TOGETHER X 2 LOCATIONS

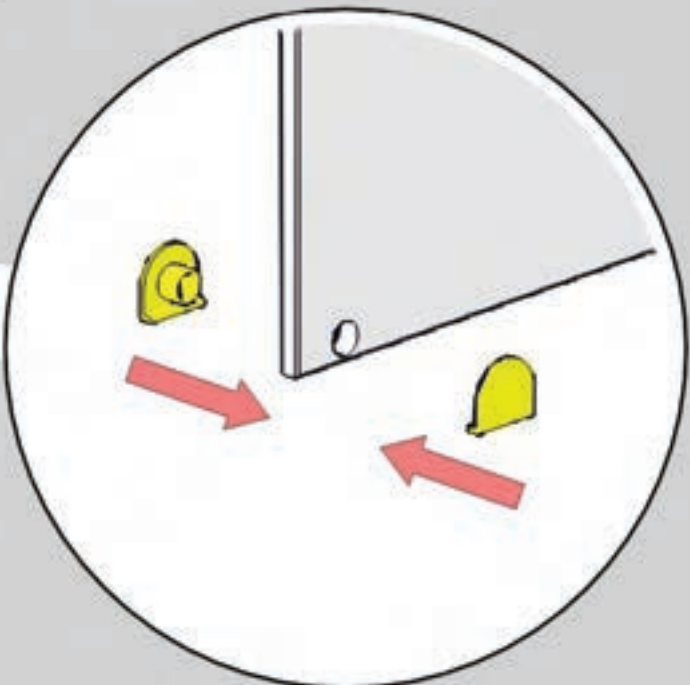

TWO PERSONS MINIMUM

1 LIFT THE DOOR INTO THE DOOR TRACK

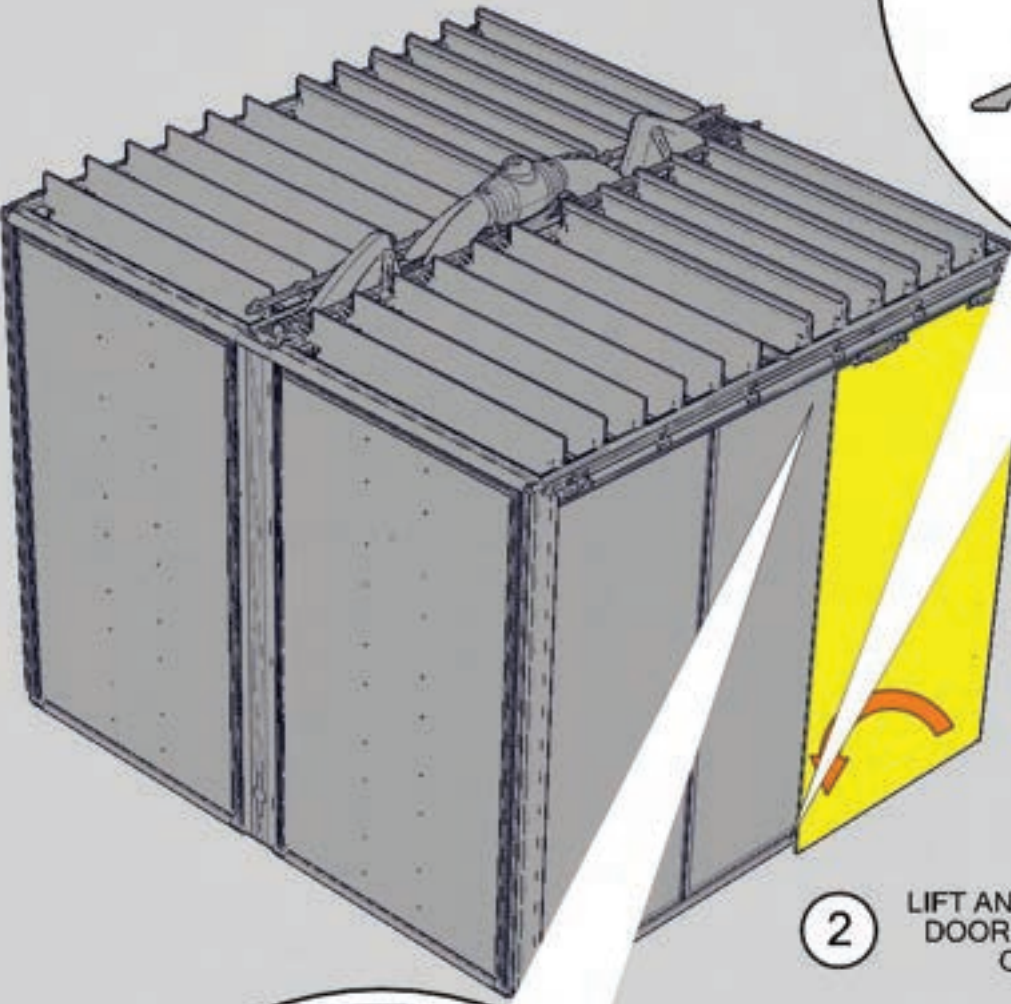
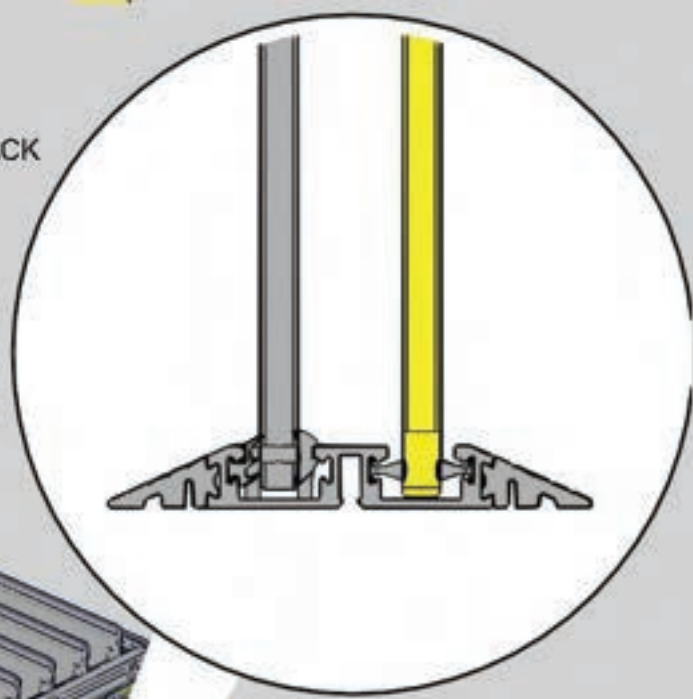

2 LIFT AND LOCATE THE DOOR ONTO THE TOP DOOR TRACK ENSURING THE WHEELS SIT ON THE EXTRUSION AS SHOWN

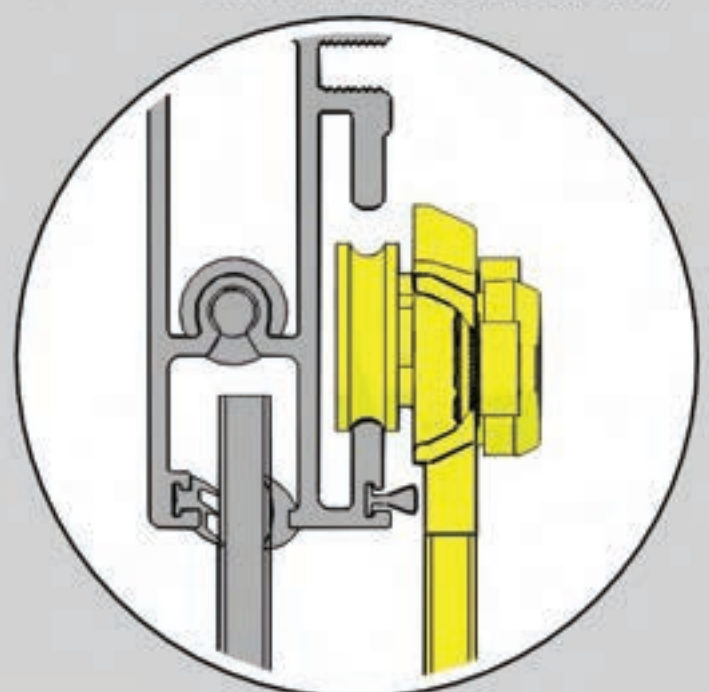
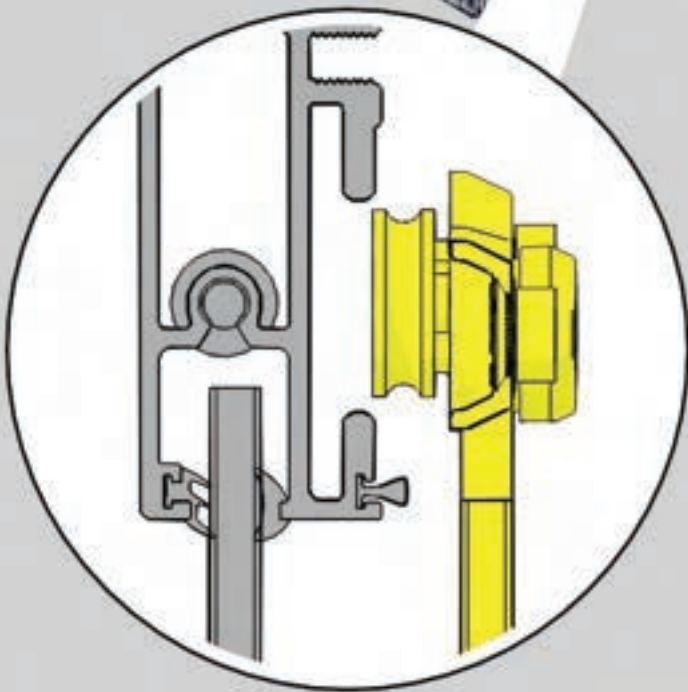

TWO PERSONS MINIMUM

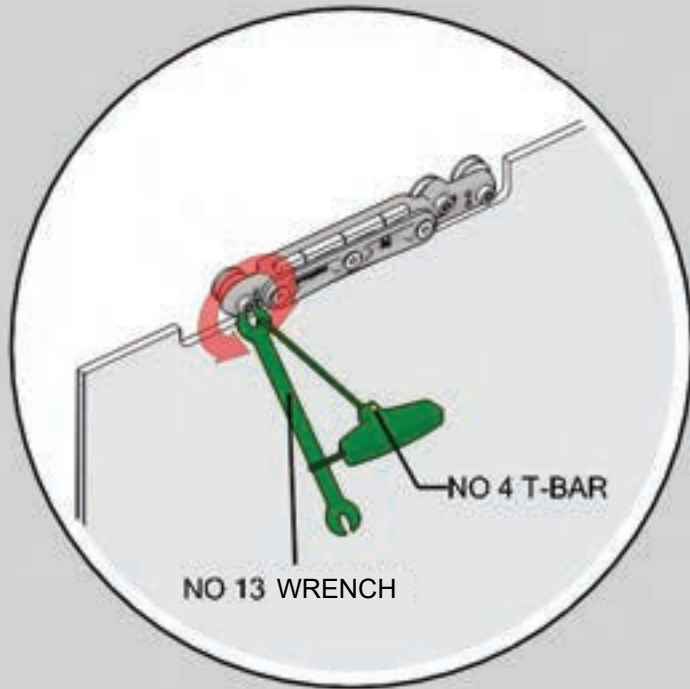

TORQUE
5NM (3.69 FT-LBF)

NO 4 T-BAR

NO 13 WRENCH



ADJUST THE RUNNERS AS INSTRUCTED TO TIP THE
DOOR UP AND DOWN AND THEN LOCK INTO POSITION
ENSURING THE DOOR IS STRAIGHT AND RUNS SMOOTHLY



ONE PERSON MINIMUM

SEE PAGE 10.11 - 10.12



THE DOOR MUST NOW BE ADJUSTED TO ENSURE IT RUNS VERTICALLY INTO THE DOOR UPRIGHT

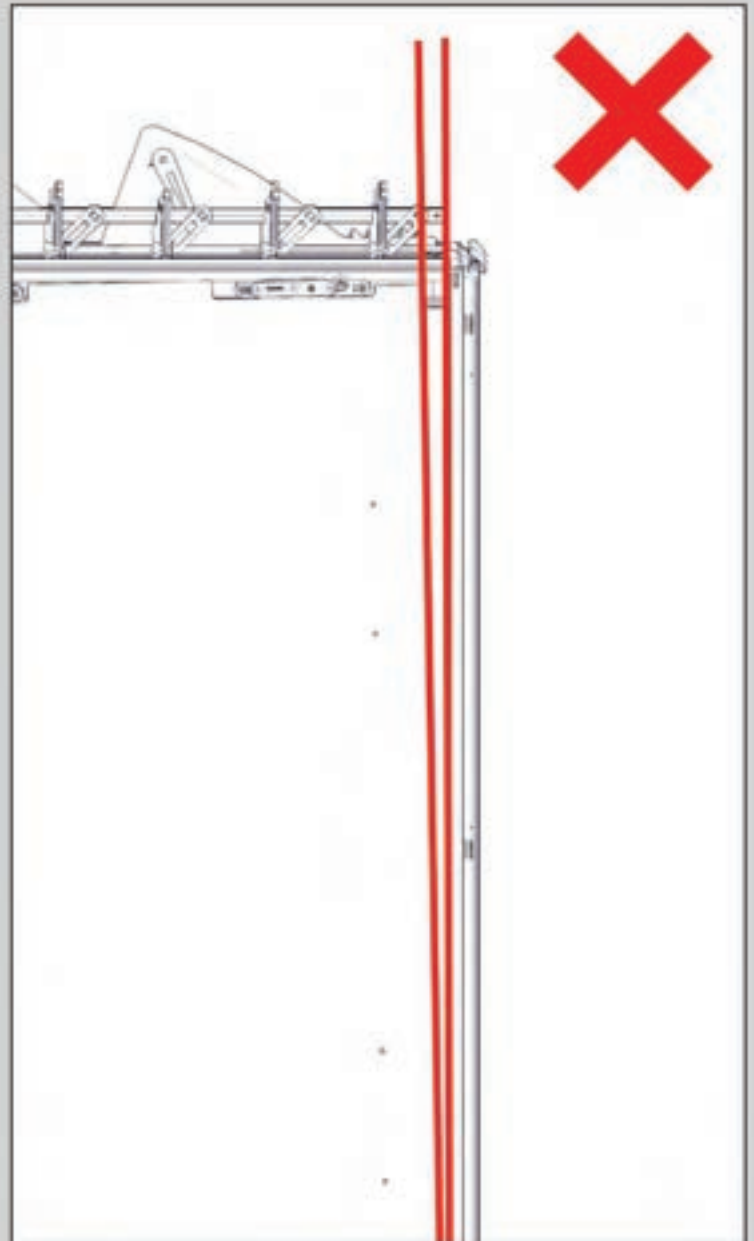
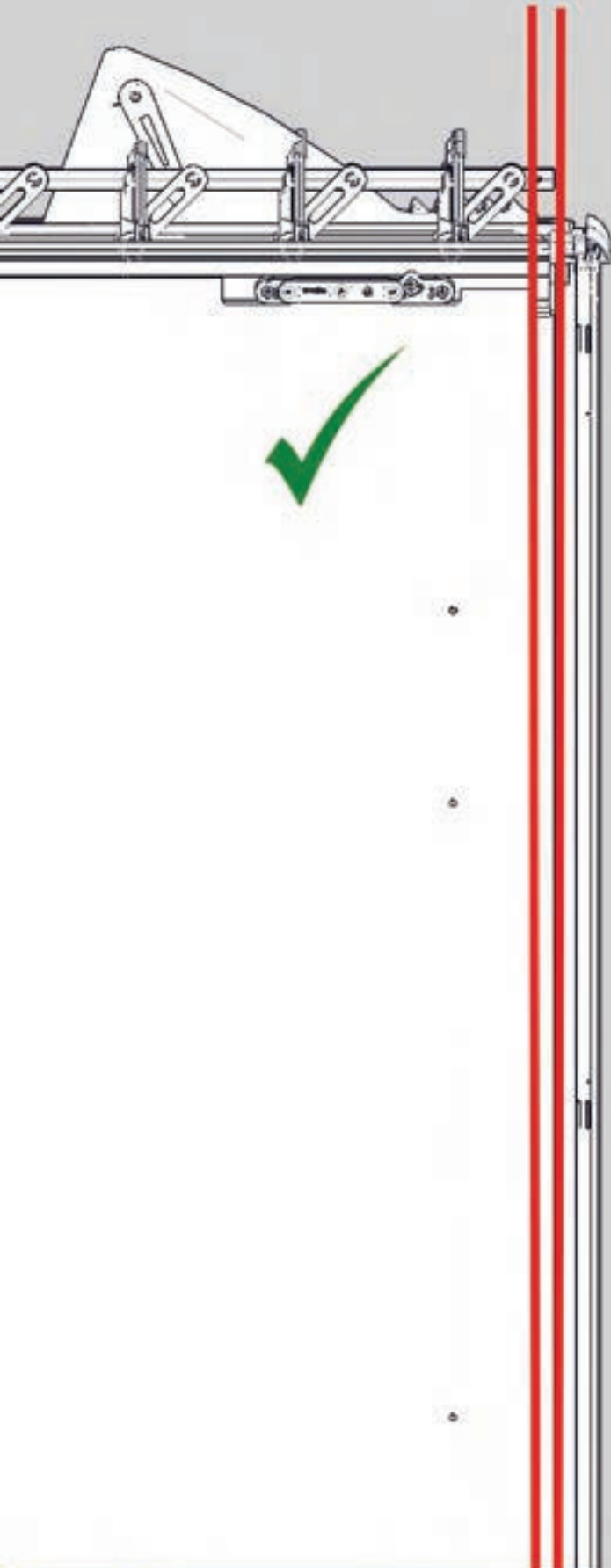

ENSURE DOOR DOES NOT SCRAPE ON BOTTOM DOOR TRACK



ONE PERSON MINIMUM

SEE PAGE 10.11

1 ADJUST THESE 2 OUTER WHEELS FIRSTLY TO SET POSITION AND ANGLE OF DOOR

2 ADJUST THESE 2 INNER WHEELS SECONDLY TO SUPPORT POSITION OF RUNNERS

TORQUE
5NM (3.69 FT-LBF)

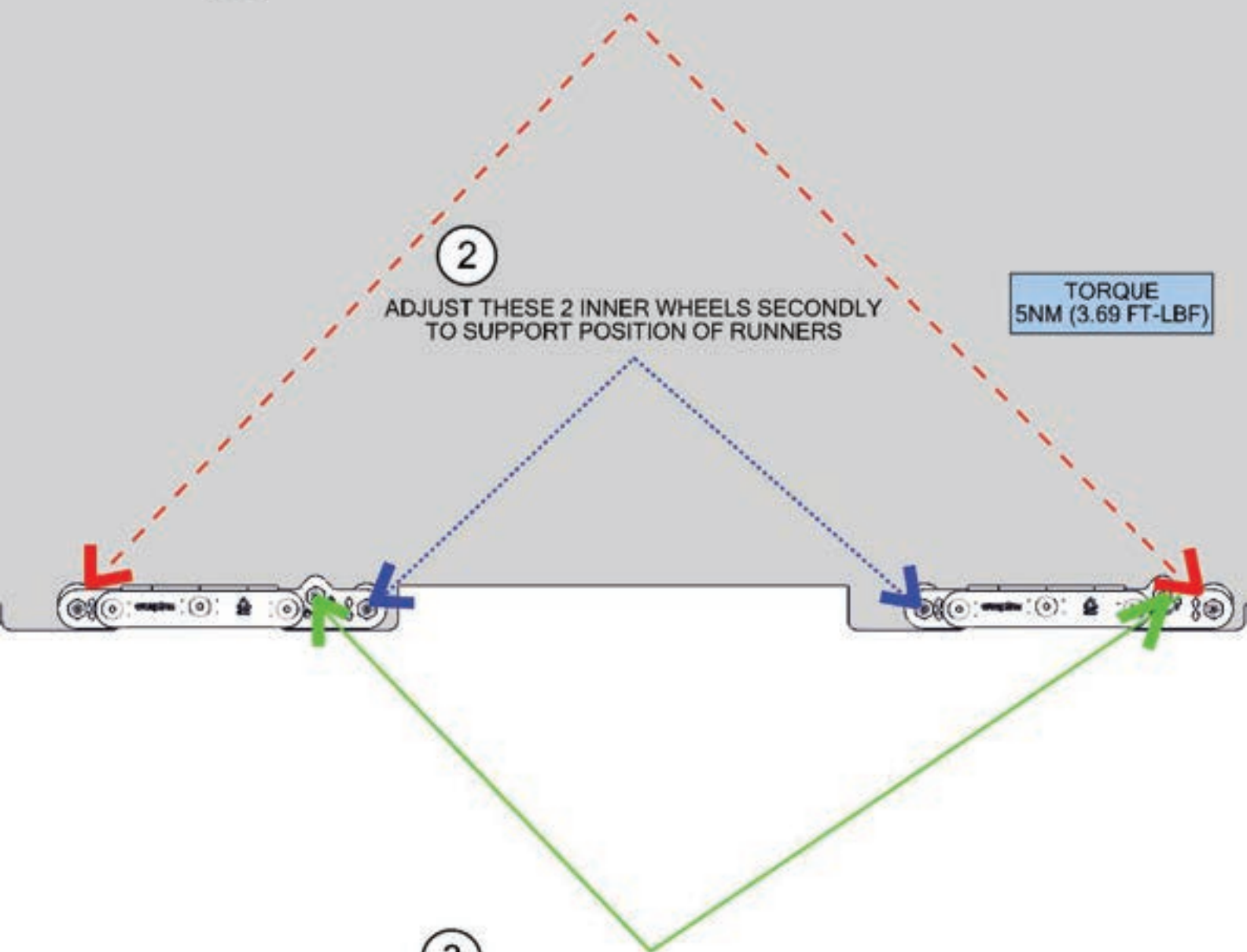

3 ADJUST THESE 2 LOCKING WHEELS THIRDLY TO ENSURE RUNNERS CANNOT COME OFF THE TRACK DO NOT FULLY TIGHTEN AGAINST EXTRUSION AS THIS WILL PREVENT THE DOOR FROM MOVING - LEAVE APPROX 1MM GAP BETWEEN WHEEL AND TRACK



DOOR OPEN / CLOSE FORCE
MAXIMUM NM = 22.5N (5LBS)
MEASURE FORCE USING A NM GAUGE



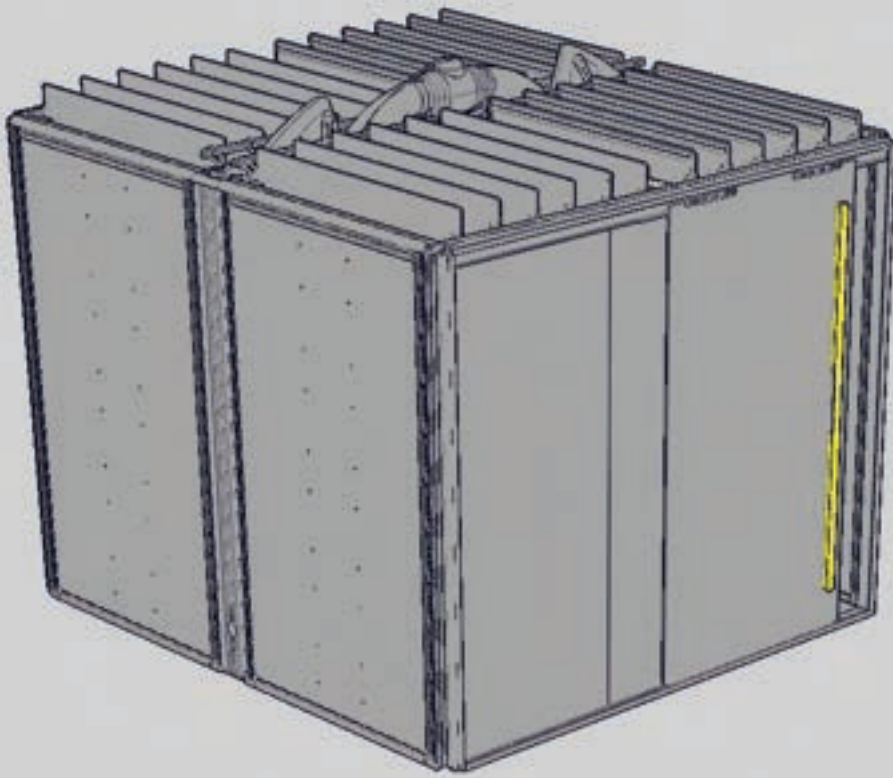

ENSURE NYLON SPACERS ARE USED BETWEEN ALL 4 BOLTS/FIXINGS AND GLASS

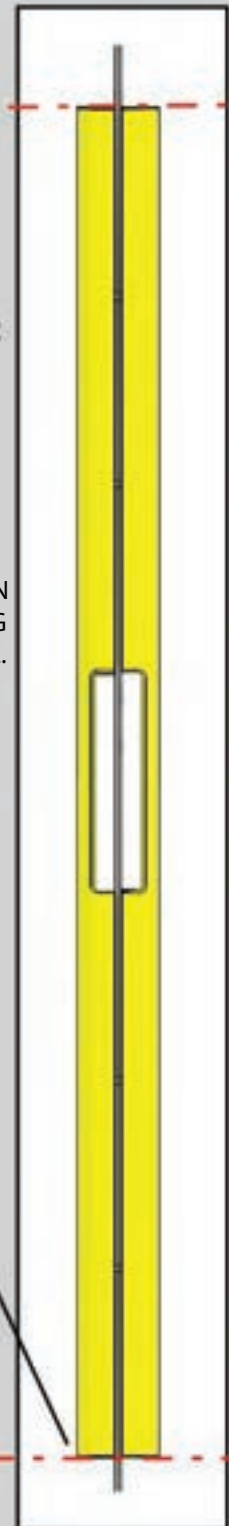
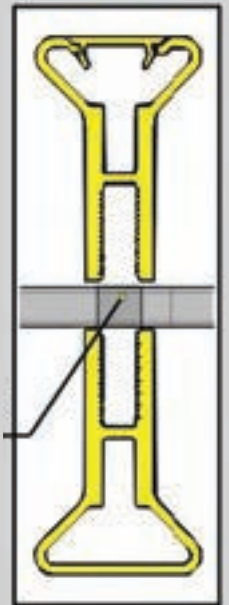

2

OFFER HANDLES UP TO HOLES IN GLASS

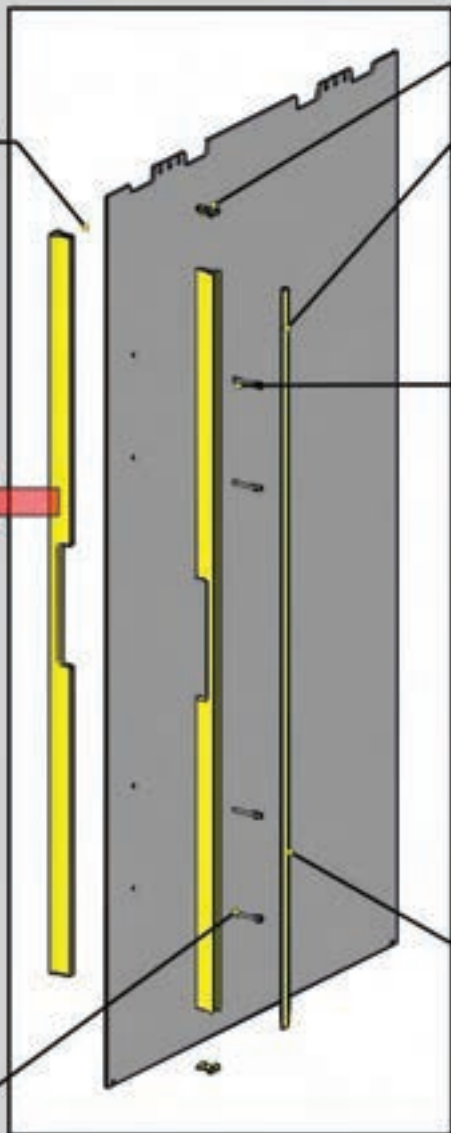

1

REMOVE CAPS
REMOVE PLASTIC COVER

3



PUSH BOLTS/FIXINGS THROUGH NYLON SPACES (ON INSIDE) BEFORE PUSHING INTO HOLES & SECURING INTO PLACE. DO NOT OVERTIGHTEN - RISK OF THREADING! USE FIRST BOLT/FIXING TO ALIGN HEIGHT OF HANDLES

4



ENSURE HANDLES ARE LEVEL AND STRAIGHT BEFORE TIGHTENING TO

**TORQUE
5NM (3.69 FT-LBF)**

5

REPLACE PLASTIC COVER

M8X60 (NO.6)



TWO PERSONS MINIMUM

SEE PAGE 10.13

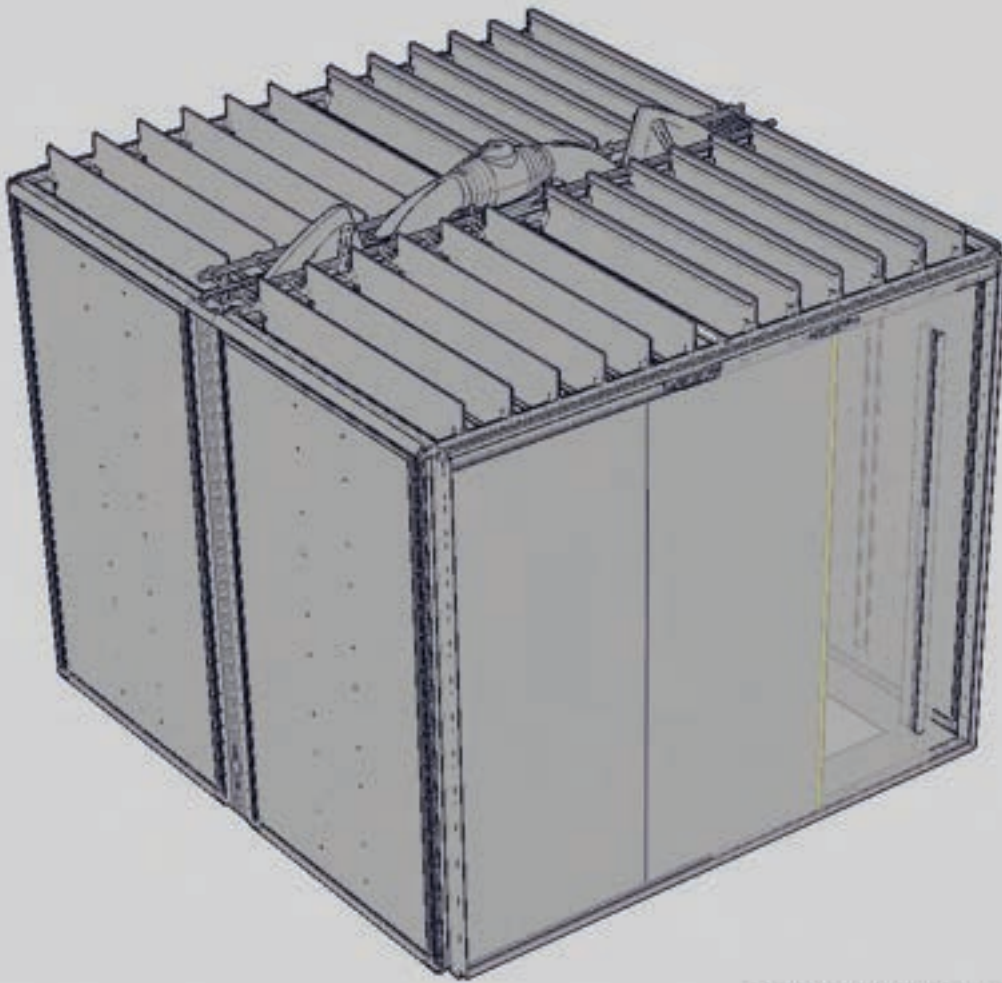

THE SEAL MUST ALWAYS TOUCH THE GLASS AS SHOWN BELOW. DO NOT USE THE SHORT SEAL ON THE SQUARE POD IF IT IS GOING TO LEAVE A GAP

PEEL OFF STRIP TO REVEAL BONDING SURFACE

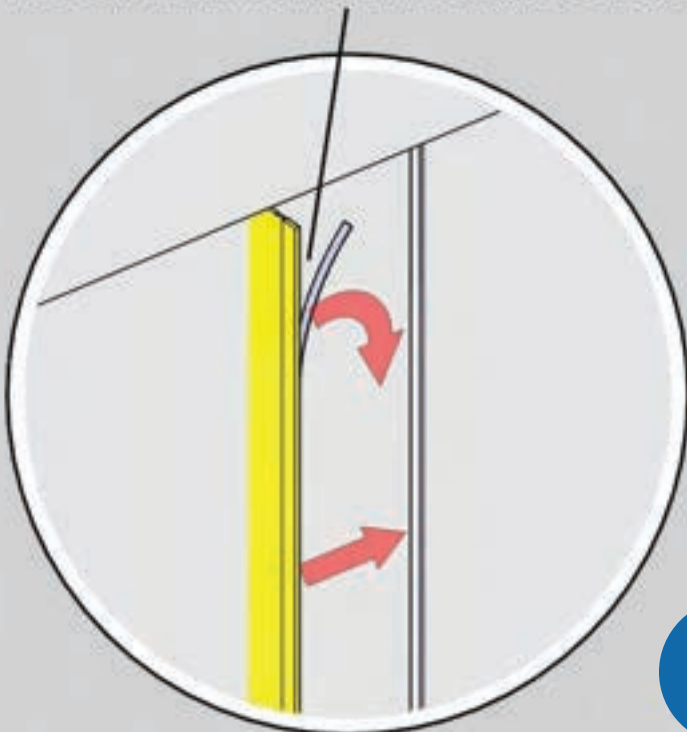

LOCATE STRIP ONTO EDGE OF INTERNAL FIXED PANEL
EDGE OF GLASS MUST BE CLEANED FIRST!!!
SEE SECTION 10.7 OF THE KNACK

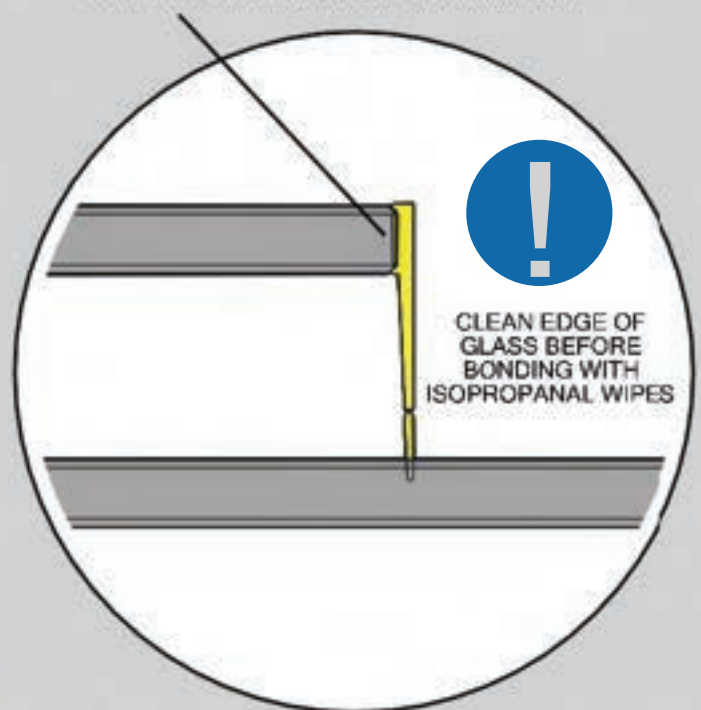

TAKE YOUR TIME ALIGNING THIS SEAL TO ENSURE IT FITS FLUSH WITH THE GLASS AT BOTH SIDES



ONE PERSON MINIMUM

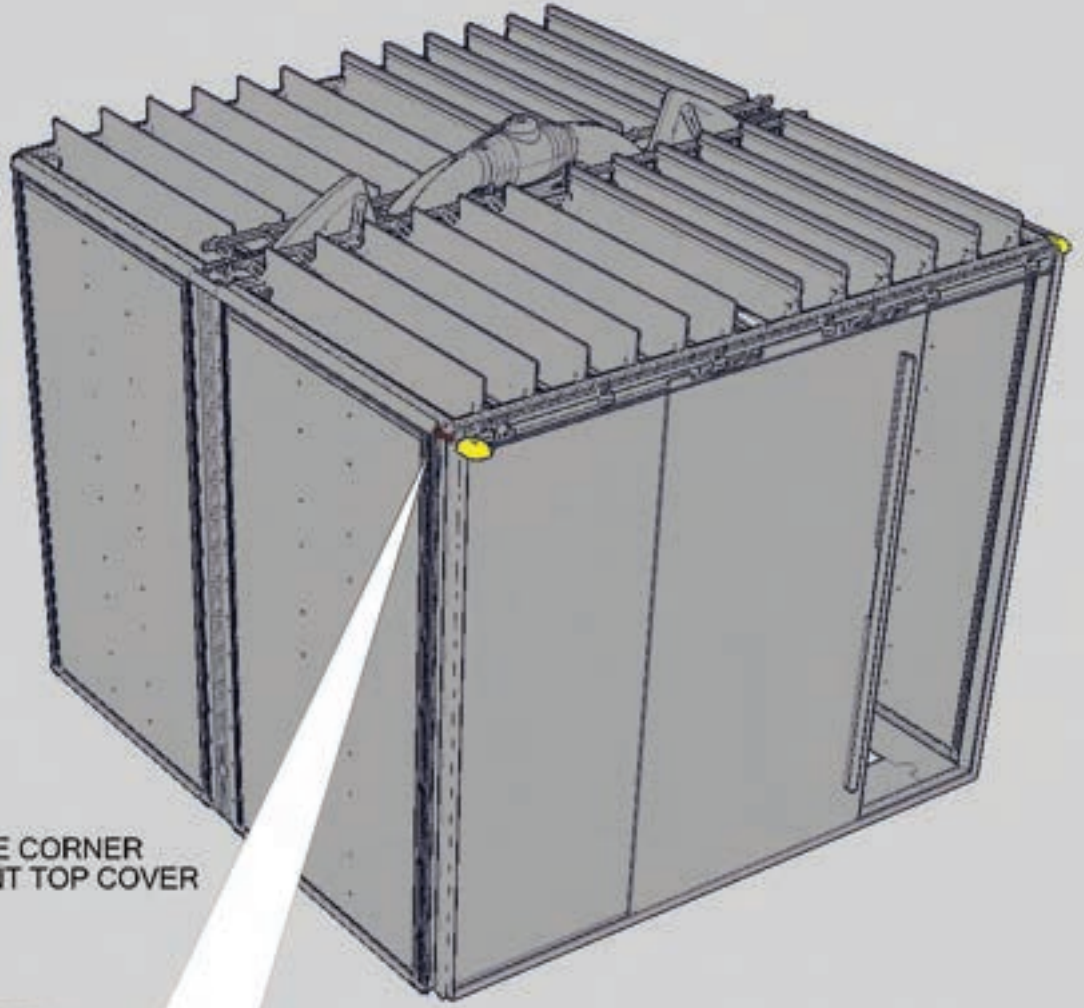

ENSURE YOU PUT THESE CORNER CAPS ON BEFORE THE FRONT TOP COVER

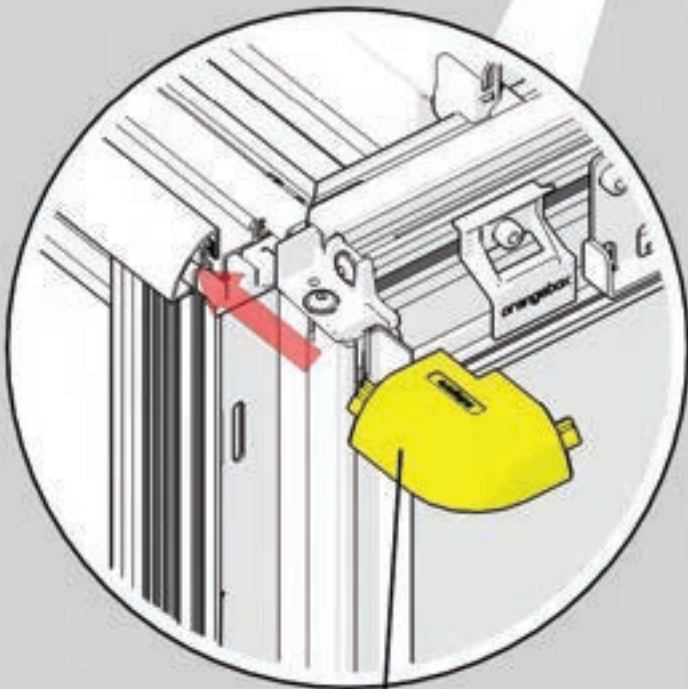

ENSURE CAPS ARE PUSHED ALL THE WAY IN AND ARE LEVEL

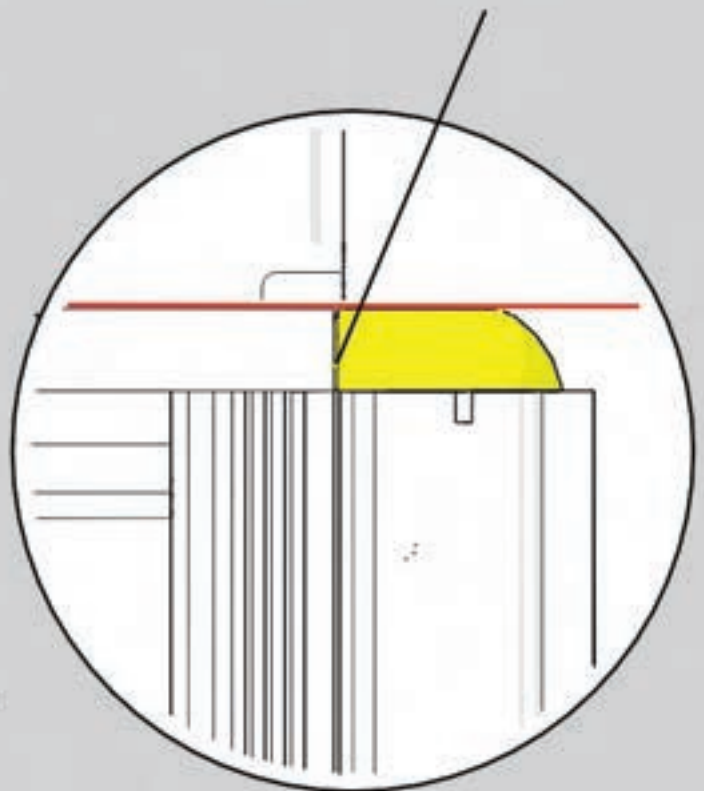

1 PUSH THE CORNER CAPS INTO THE SCREEN CROSSBAR COVER AS SHOWN IN X4 CORNERS



ONE PERSON MINIMUM

SEE PAGE 10.16

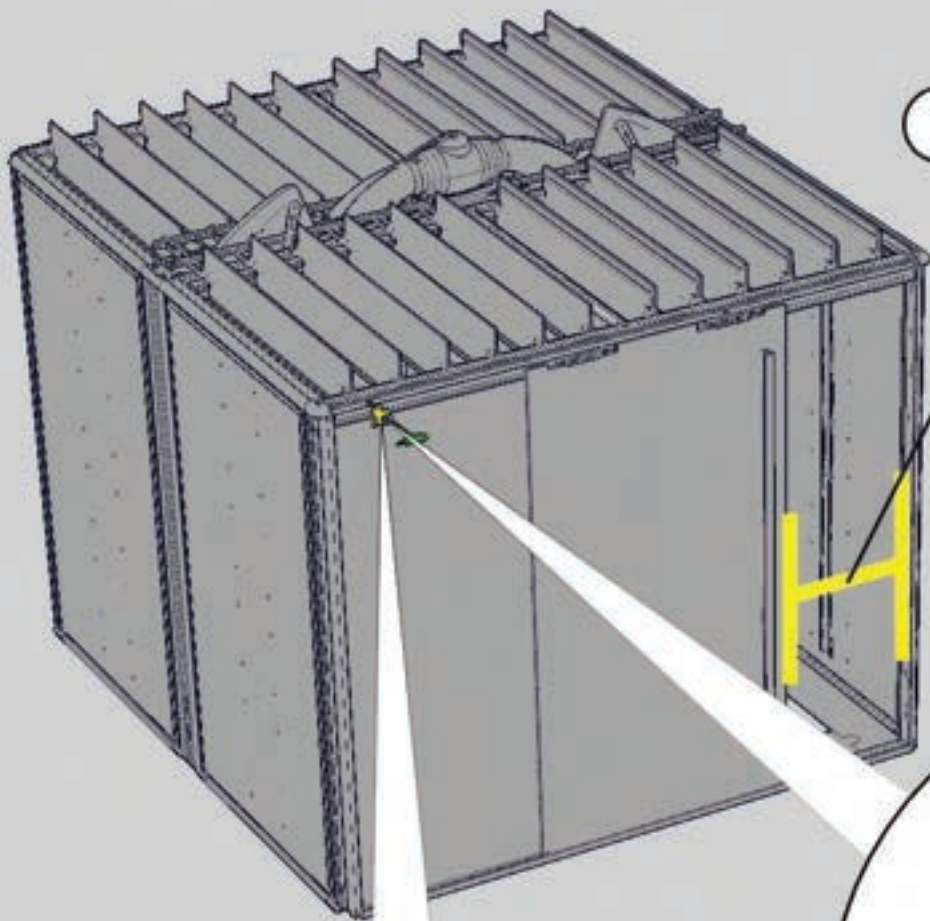

1

DOOR OPENING MUST MEASURE 825MM (32.5") MEASURE THIS OPENING AND THEN SECURE BRACKET



2

PEEL OFF TAPE AND BOND FOAM ONTO BRACKET

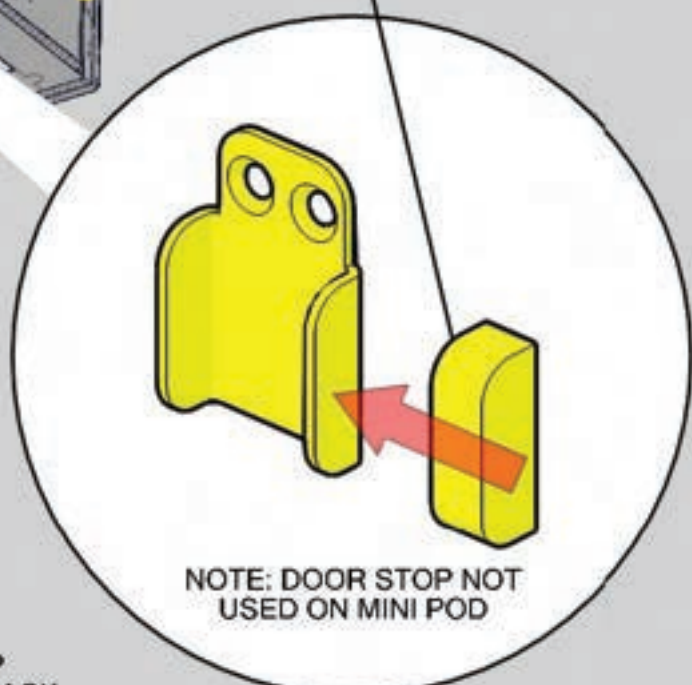

NOTE: DOOR STOP NOT USED ON MINI POD

3

ATTACH DOOR STOP ONTO TOP DOOR TRACK

570MM (22.4") BETWEEN BRACKET AND UPRIGHT

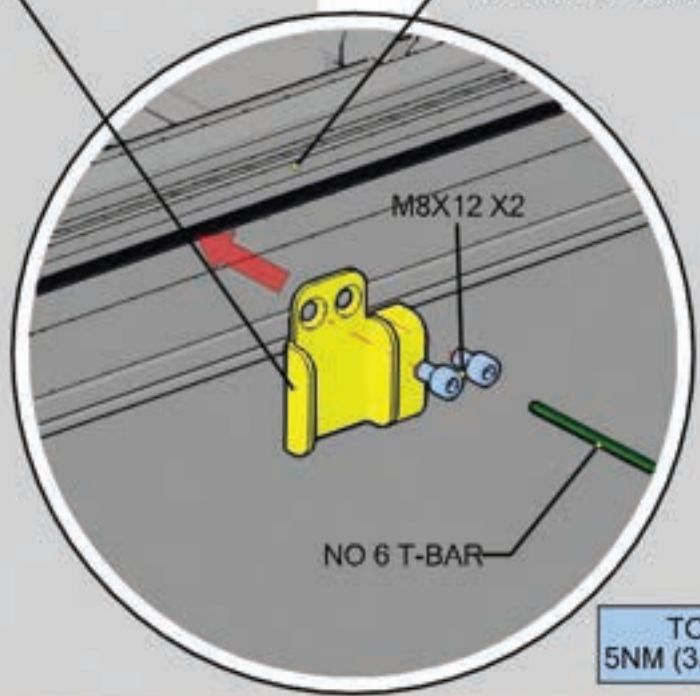

M8X12 X2

NO 6 T-BAR

TORQUE 5NM (3.69 FT-LBF)

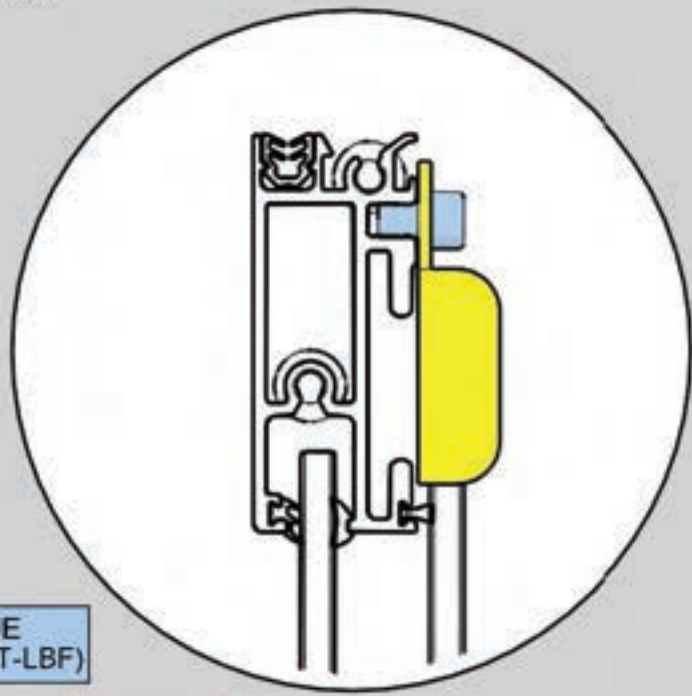

ONE PERSON MINIMUM

REPEAT THIS PROCESS OF ADDING THE COVER CLIPS AT THE FRONT AND REAR OF THE POD

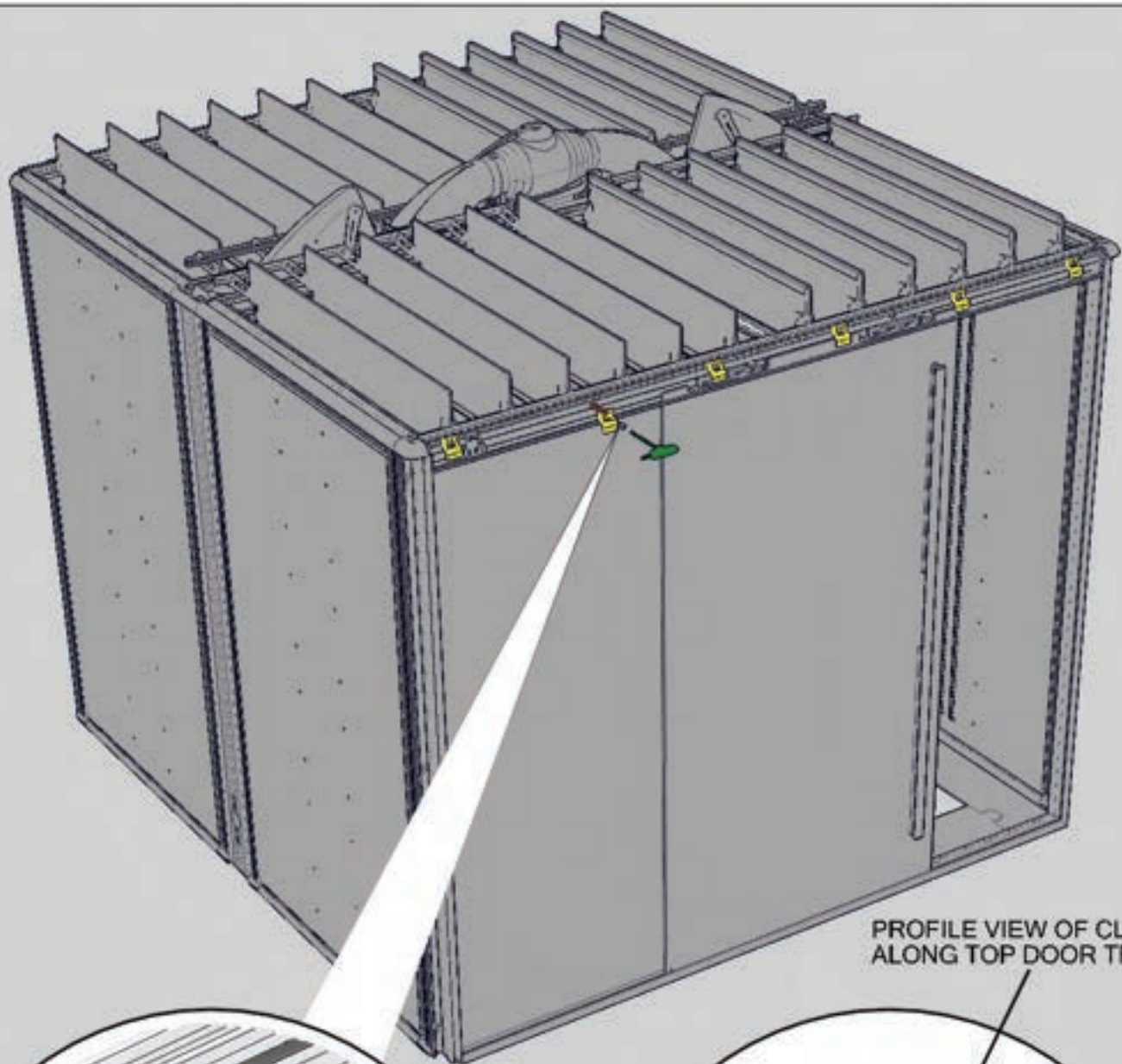

PROFILE VIEW OF CLIP ALONG TOP DOOR TRACK

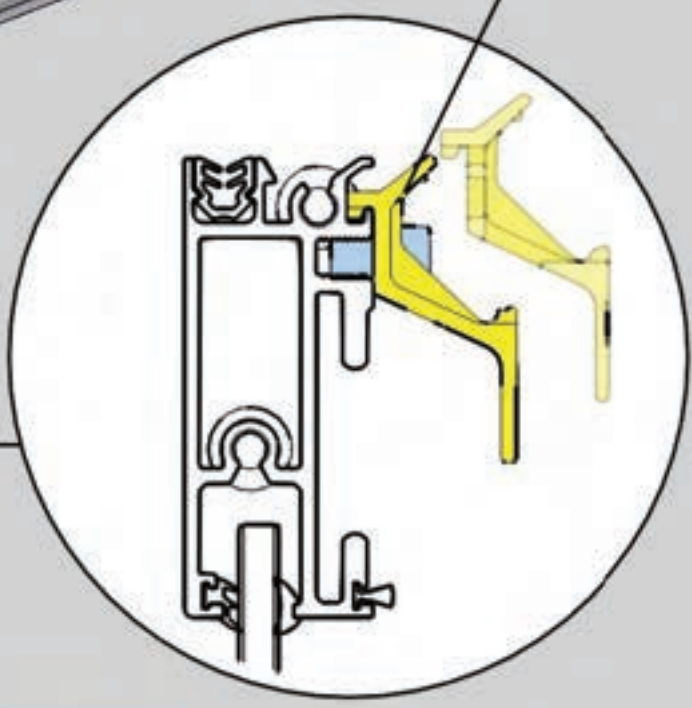
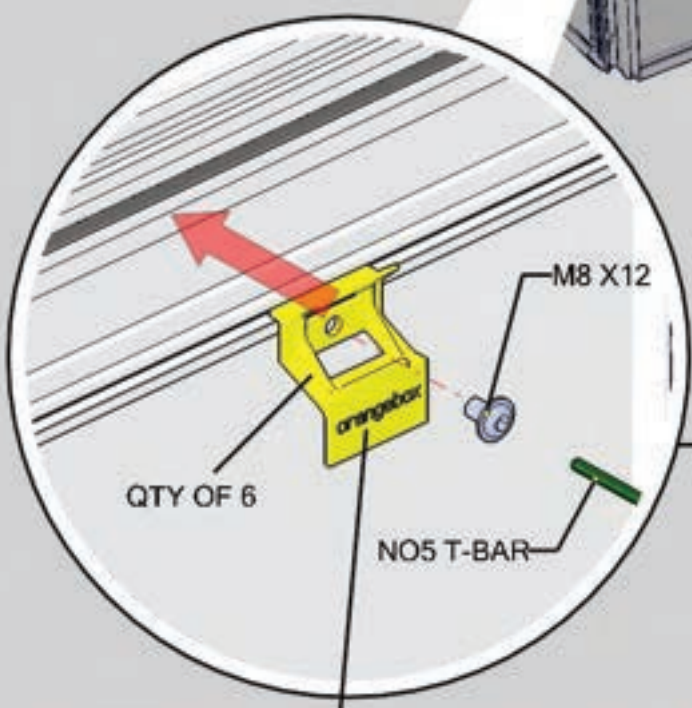

SPREAD X6 MOULDINGS EVENLY ALONG THE TOP DOOR TRACK ENSURING YOU START WITH A MOULDING EACH END OF THE EXTRUSION

TORQUE 5NM (3.69 FT-LBF)



ONE PERSON MINIMUM

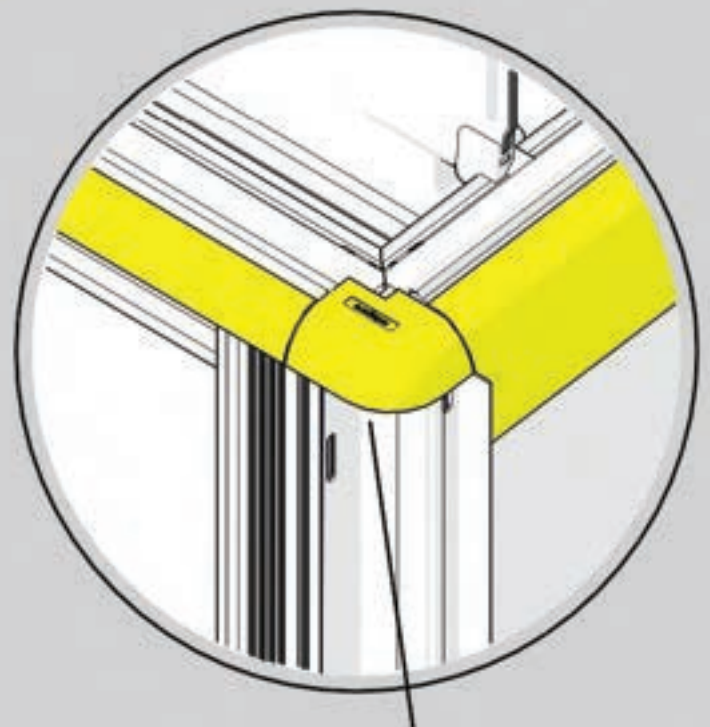
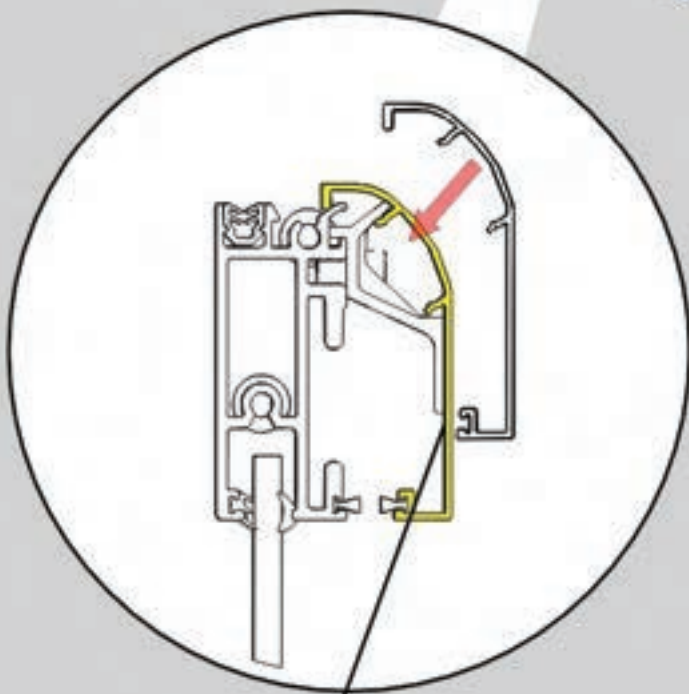
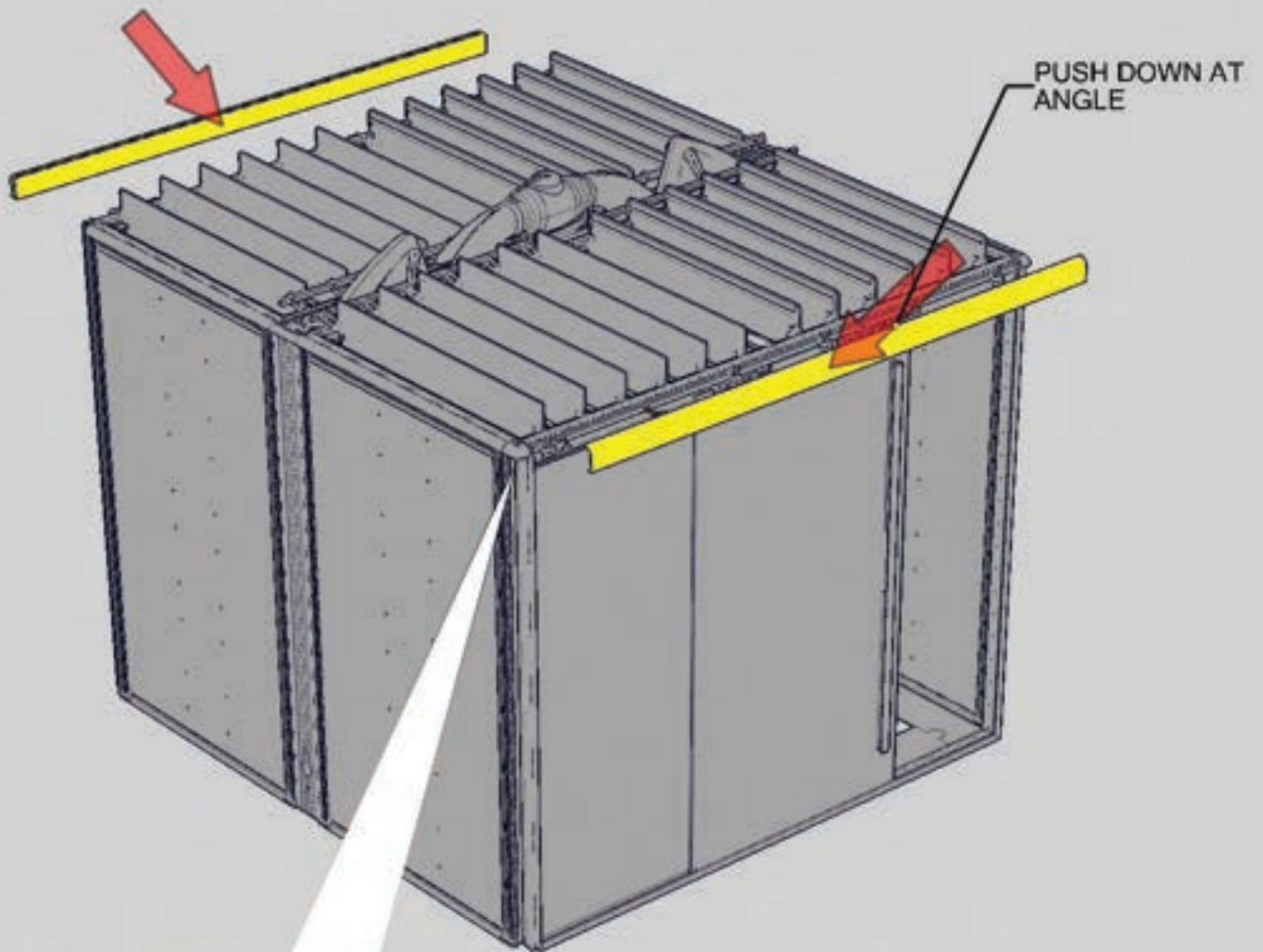

LOCATE THE COVERS ONTO THE TOP DOOR TRACK CLIPS AS SHOWN. ENSURE THAT THE COVER ENGAGES THE CLIPS FROM THE TOP AND YOU PRESS DOWN ON THE COVER AT THE ANGLE SHOWN WORKING ALONG THE EXTRUSION. SEE THE KNACK SECTION 16

THE CORNER CAP AND BOTH COVERS MUST ALL BE LEVEL AND FLOW INTO EACH OTHER WITHOUT ANY GAPS



TWO PERSONS MINIMUM

SEE PAGE 10.15 - 10.16

Assembly sequence

Accessories

section



* NO UNAUTHORISED PERSONNEL PERMITTED TO PARTICIPATE IN ASSEMBLY (ORANGEBOX CERTIFIED PERSONNEL ONLY)

*APPROPRIATE PPE MUST BE WORN AT ALL TIMES DURING ASSEMBLY OF ORANGEBOX PRODUCTS

*PART ASSEMBLED PODS MAY NOT BE LEFT UNATTENDED UNLESS STRUCTURALLY SOUND



SCREEN MOUNTED WHITEBOARDS

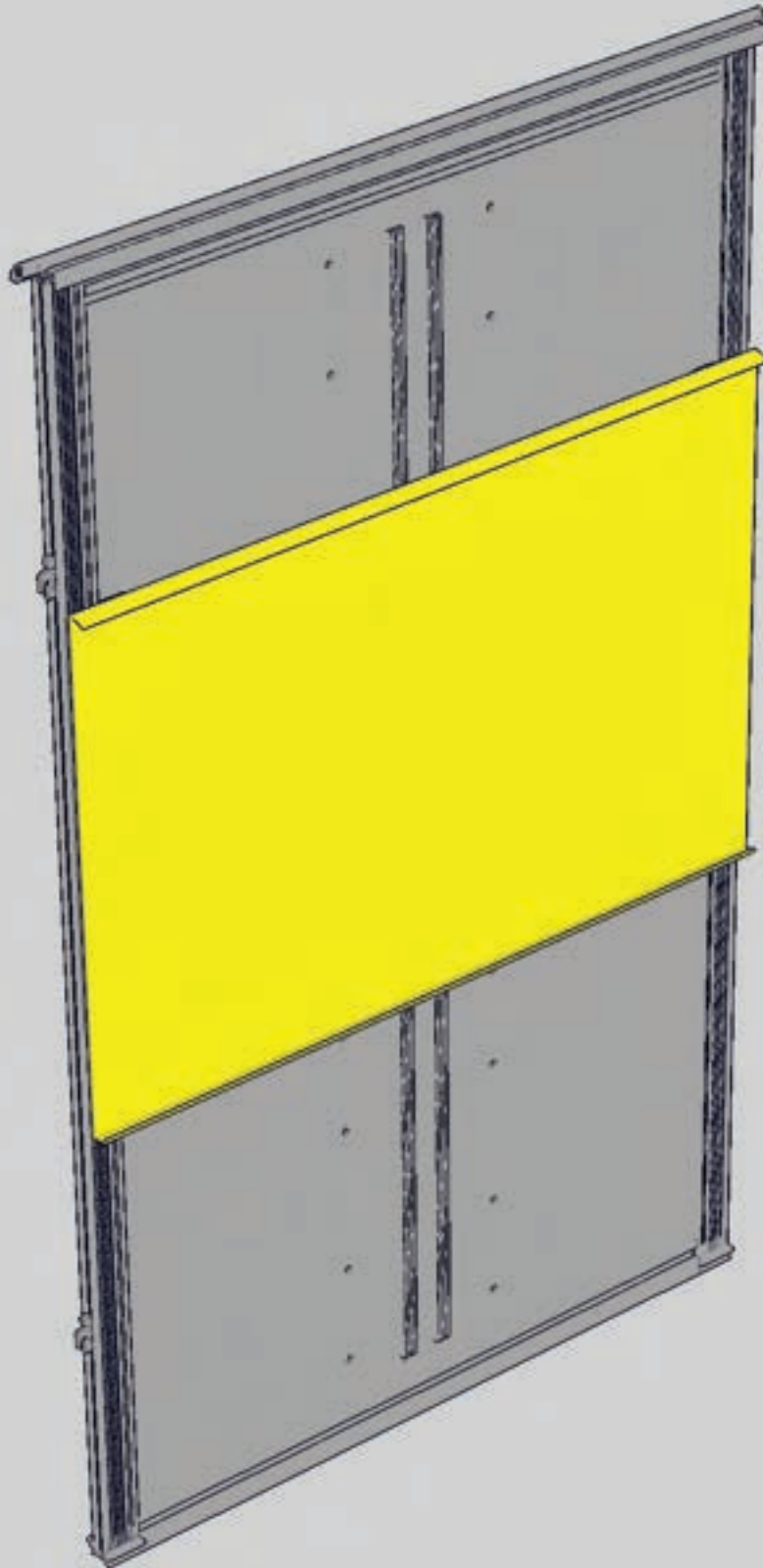

STRAIGHT MAGNETIC WHITEBOARD IS NOT UL CERTIFIED

1

BE SURE TO INSTALL BRACKETS AT THE CORRECT HEIGHT.

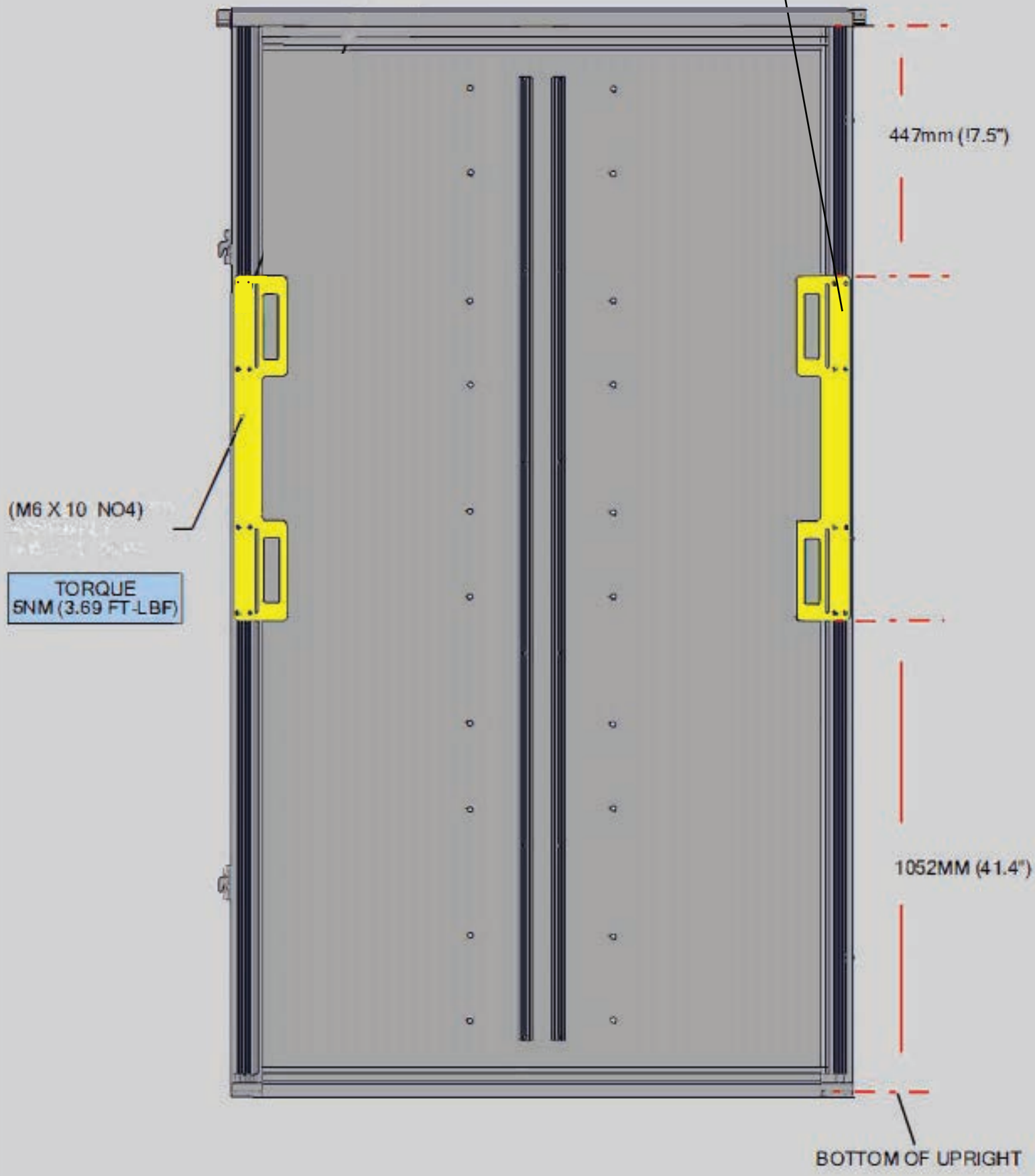

ONE PERSON MINIMUM

- 1 Wipe both top and bottom edges with isopropanol wipes before bonding strips. See section 10.7 of 'The Knack'

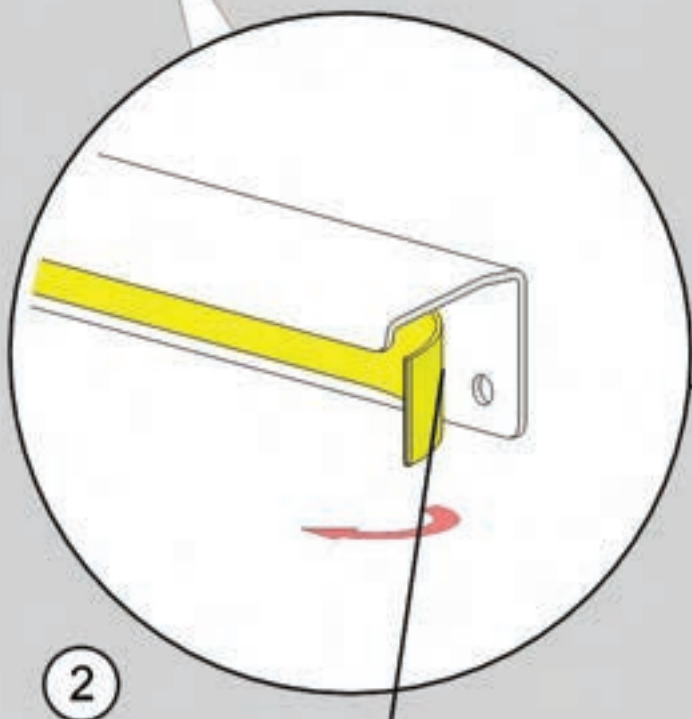
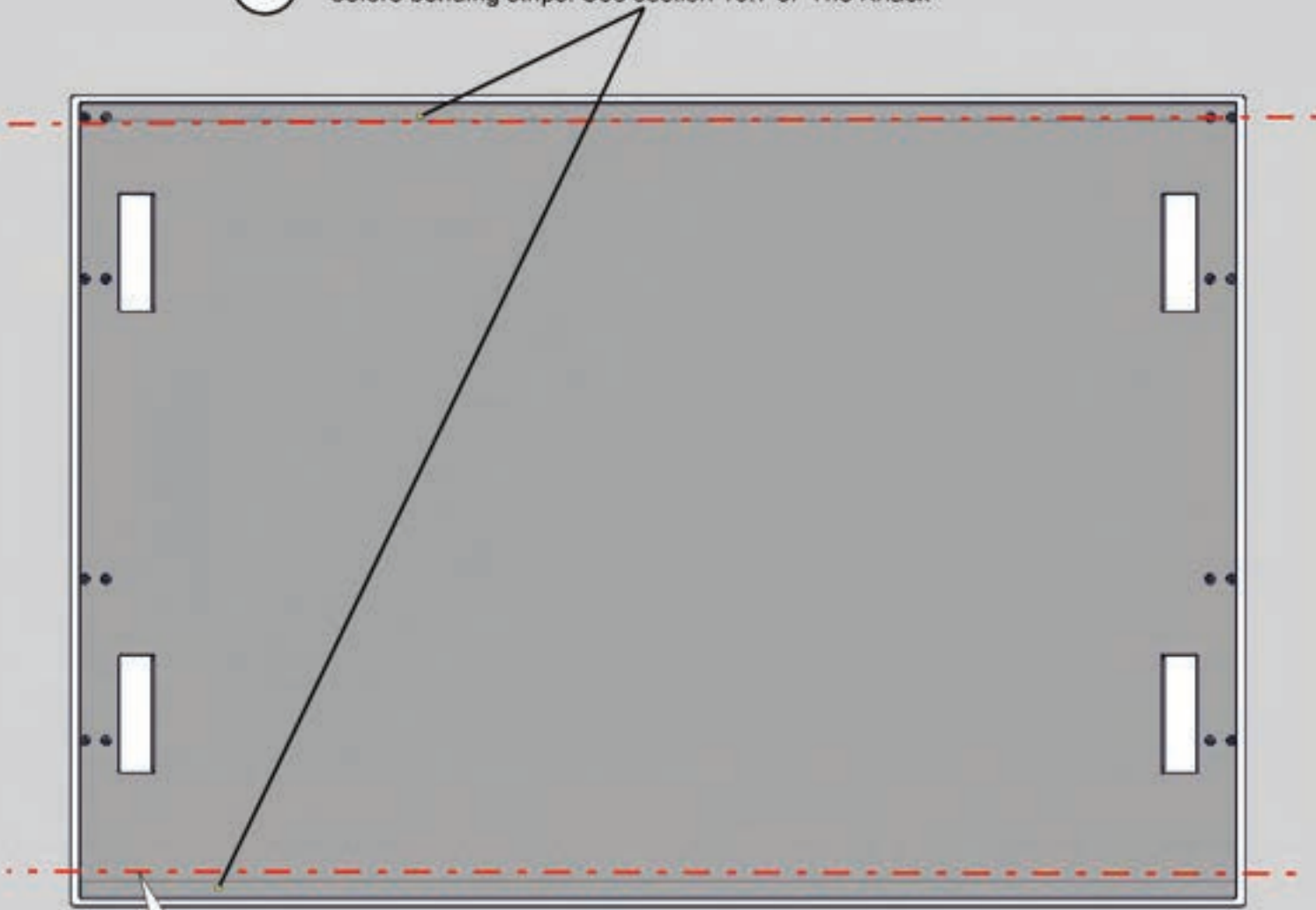

- 2 Remove tape from bonding strip and carefully bond onto clean metal surface

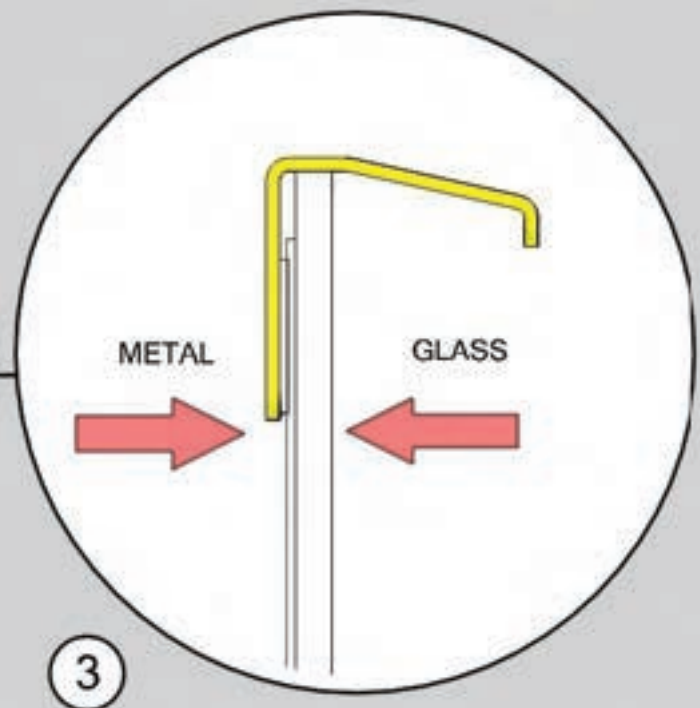

- 3 Ensure strip is bonded on correct way with the lip facing towards the glass and into the pod

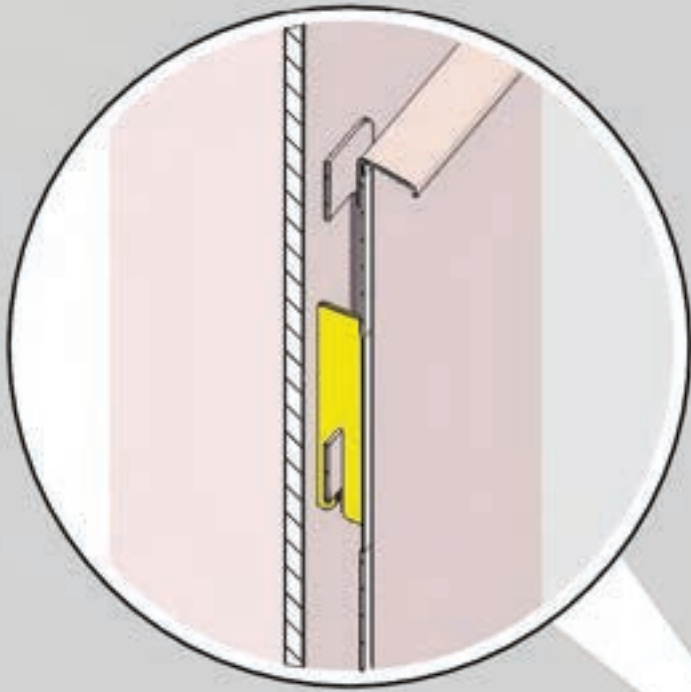

Locate all 4 brackets and slide down into place as shown
Ensure whiteboard is fully secure before leaving

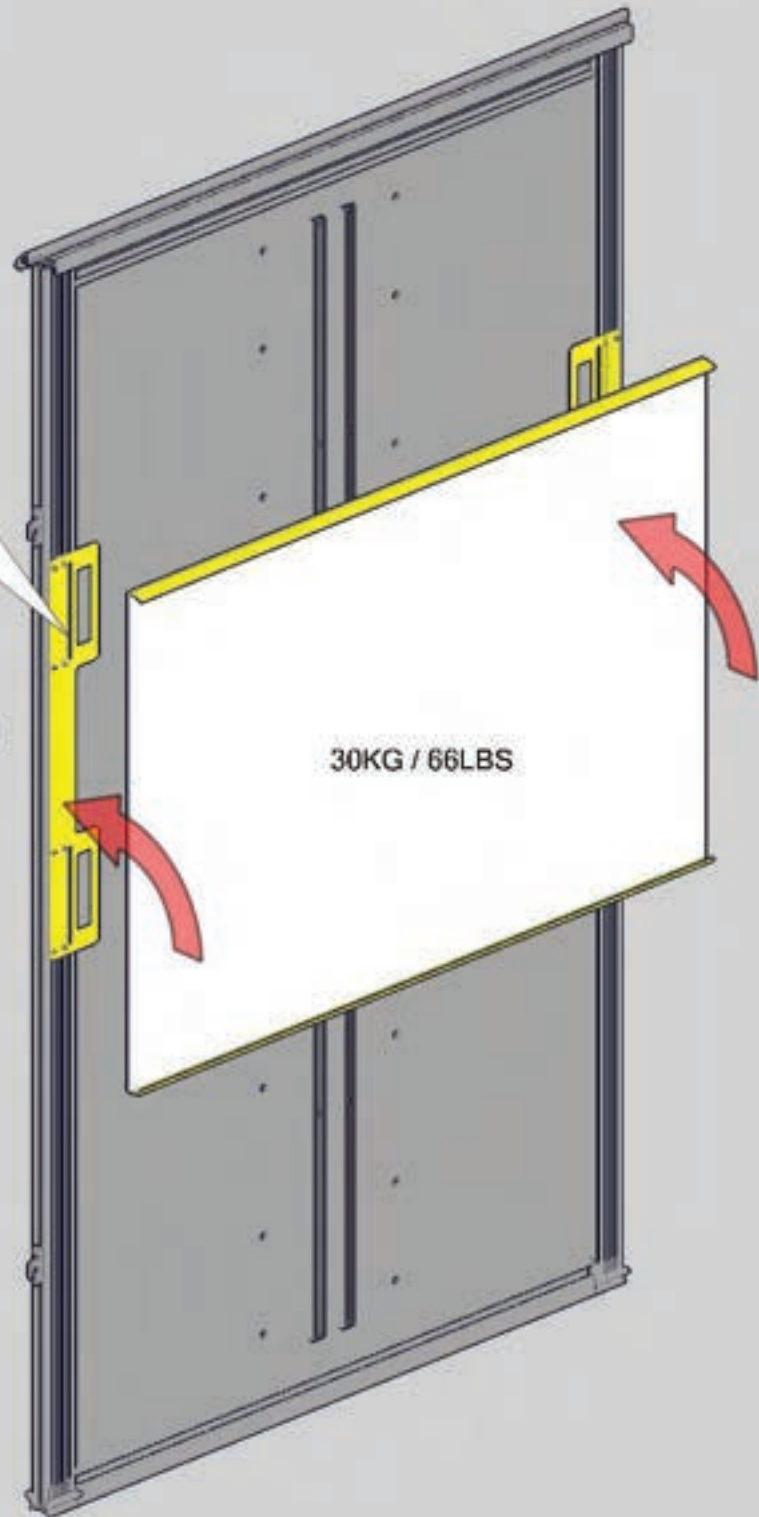

**WARNING GLASS
USE SUCTIONS HANDLES!**



TWO PERSONS MINIMUM

SCREEN MOUNTED FIXED MONITOR BRACKET

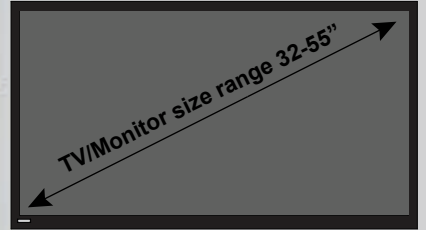
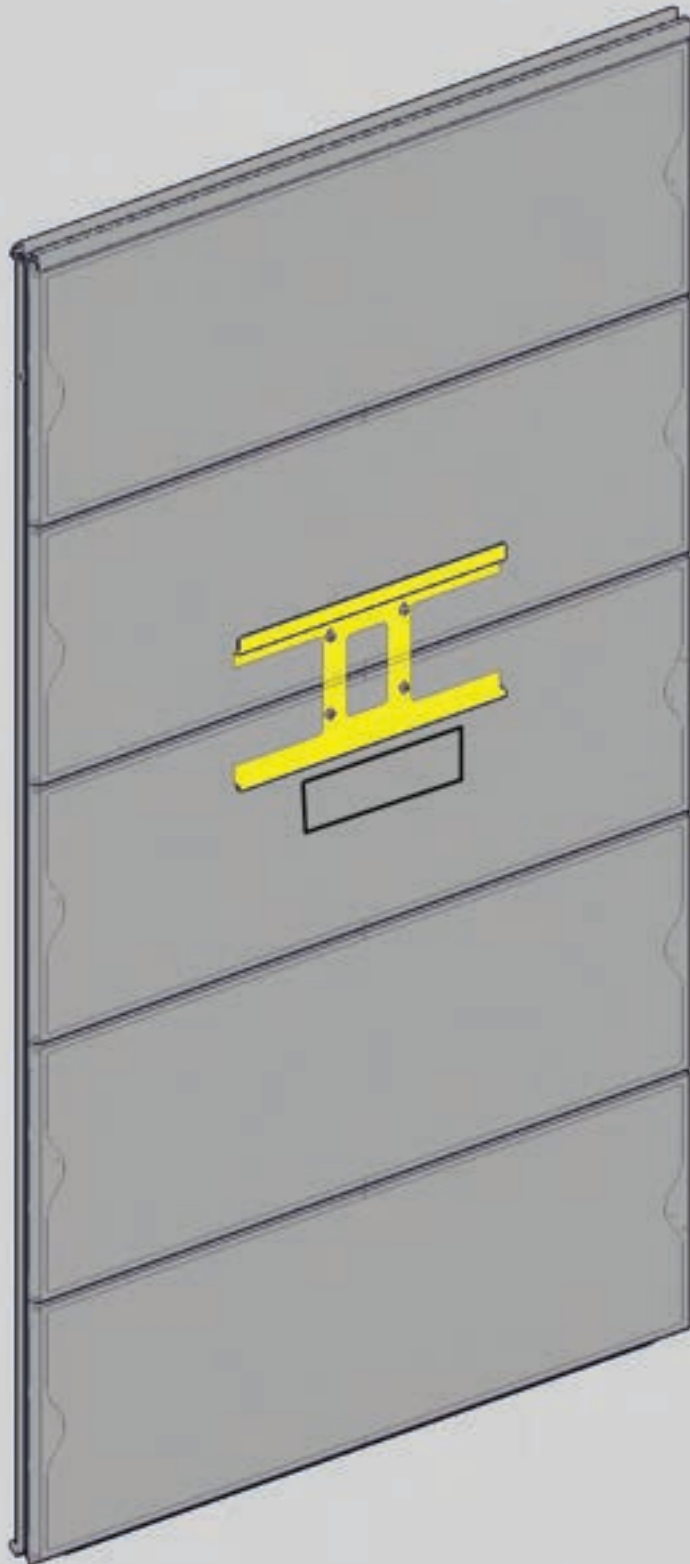

CAUTION:



25KG/55LBS LED	25KG/55LBS LCD
PLASMA	

FACTORY FITTED ONTO SCREENS
BRACKET SHOULD MEASURE 765MM FROM TOP
OF SCREEN CROSS BAR TO TOP FLAT EDGE OF
BRACKET (FIXINGS USED: QTY 8 M8 SPRING T-NUTS,
QTY 8 M8X10 FLANGE BUTTON HEAD SOCKET
& QTY 8 NUMBER 10 BTN HEAD
SELF TAP 1/2 INCH WOOD SCREWS.
NO 5 ALLEN KEY AND POZ I SCREWDRIVER)

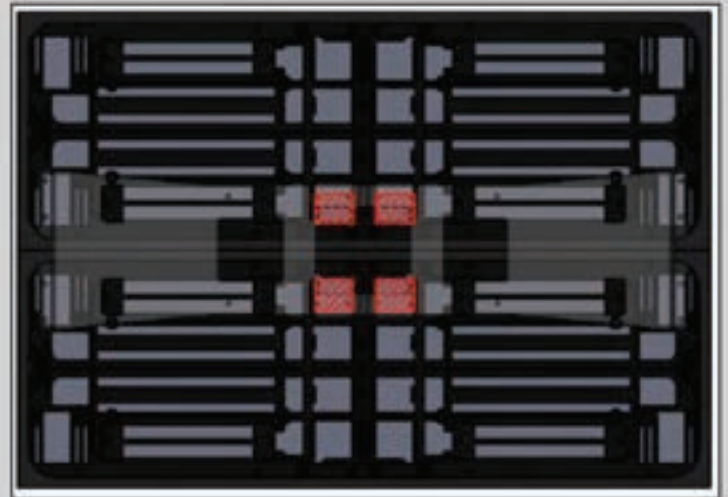
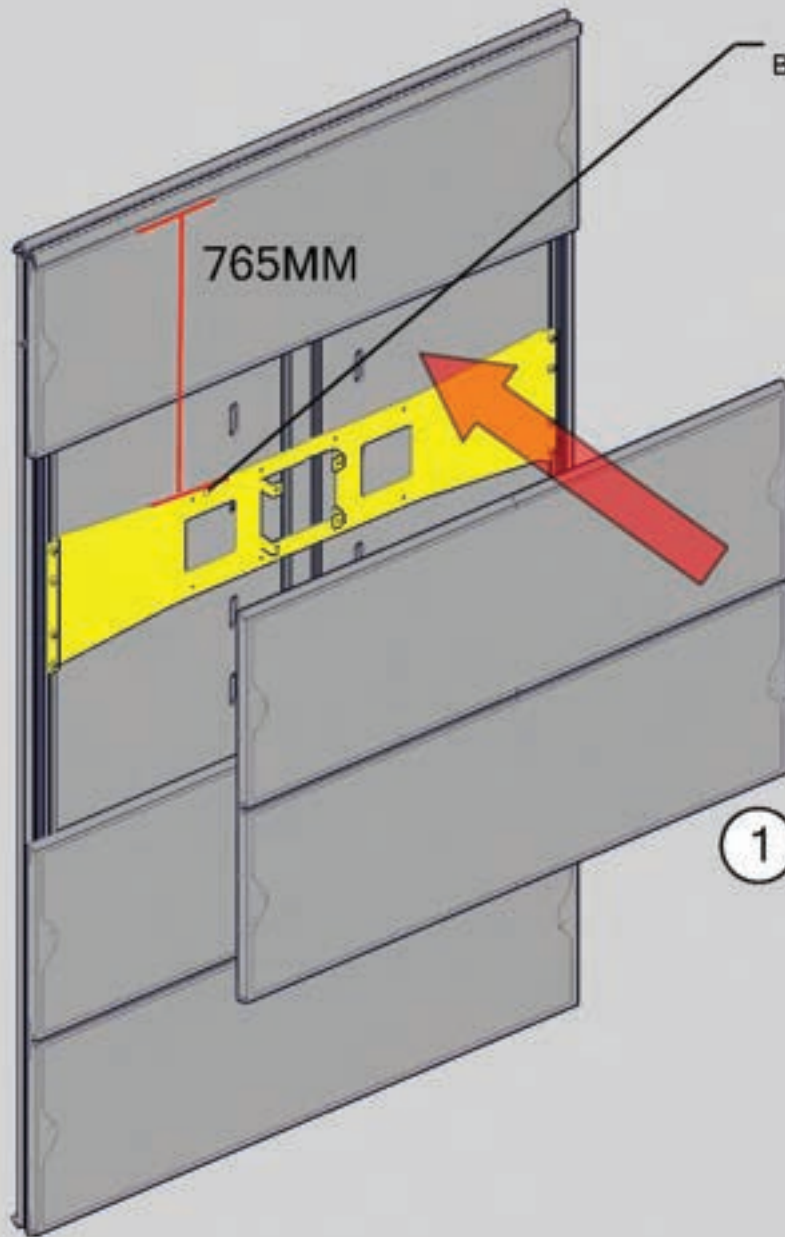

- 1 LOCATE THE UPHOLSTERY PANELS OVER THE BRACKET. THERE ARE CUT OUTS IN THE FOAM WHICH WILL FIT OVER THE BRACKET



- 2 LOCATE THE BRACKET FIXING POSITIONS THROUGH THE FABRIC

- 3 PIERCE THROUGH THE FABRIC THESE FIXING POSITIONS



ONE PERSON MINIMUM

ATTACH THE BRACKETS THROUGH THE PIERCED HOLES IN THE FABRIC INTO THE BRACKET

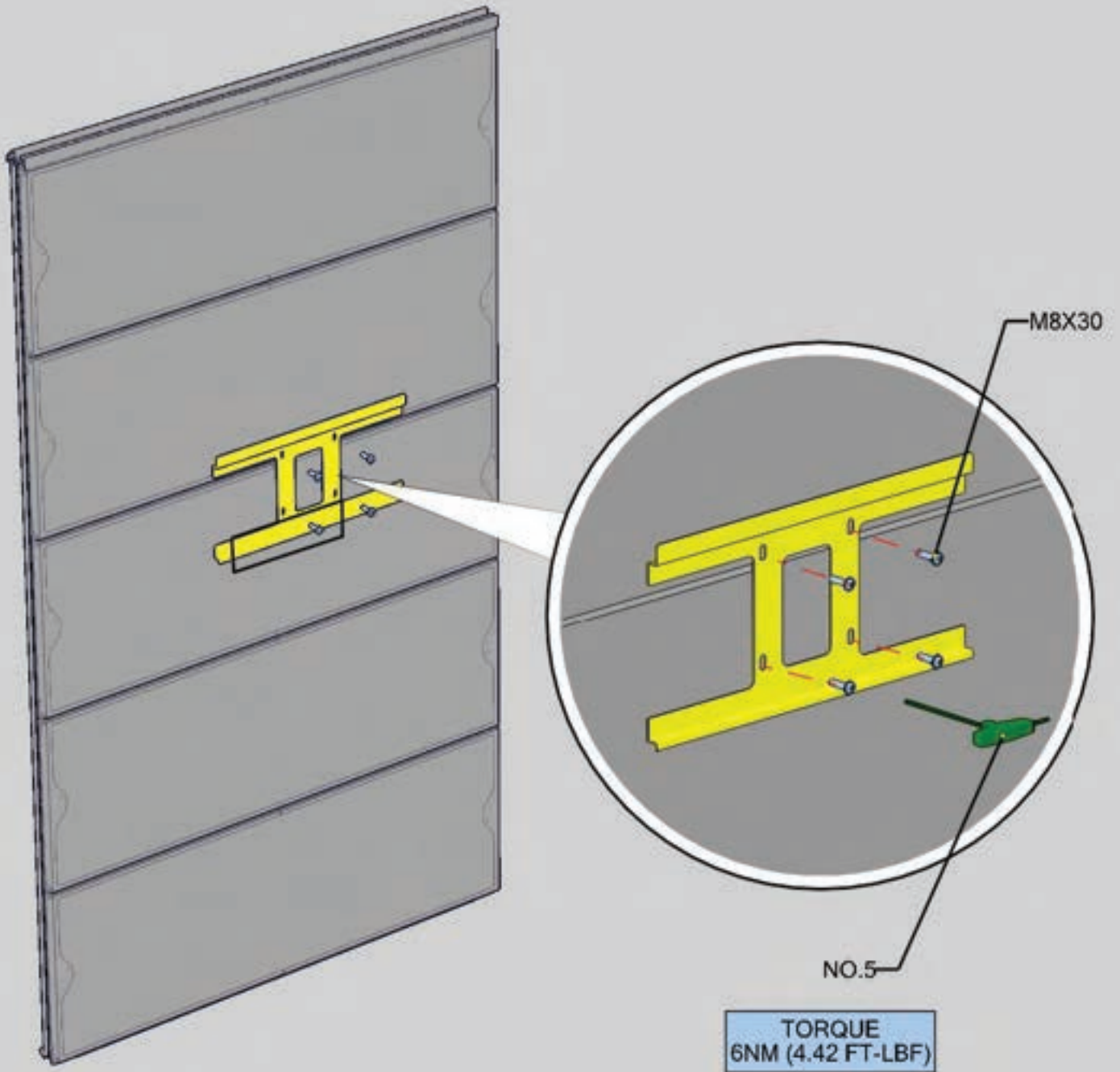

ONE PERSON MINIMUM

FIXINGS AND TOOL WILL VARY DEPENDING ON TYPE OF SCREEN AND CONNECTION METHOD

COMPATIBLE WITH:
VESA 100 X 100
VESA 200 X 200

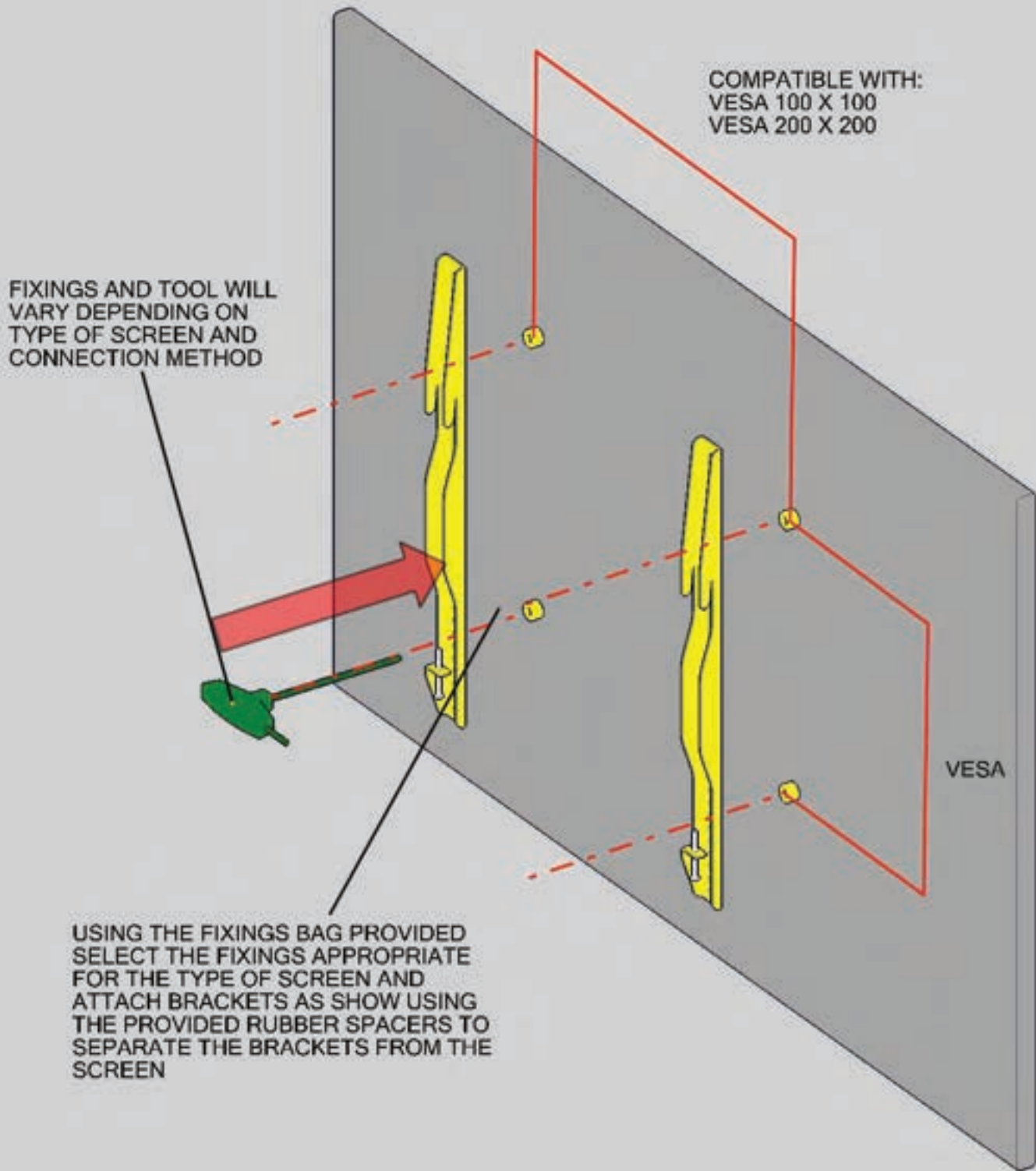

USING THE FIXINGS BAG PROVIDED SELECT THE FIXINGS APPROPRIATE FOR THE TYPE OF SCREEN AND ATTACH BRACKETS AS SHOW USING THE PROVIDED RUBBER SPACERS TO SEPARATE THE BRACKETS FROM THE SCREEN



TWO PERSONS MINIMUM

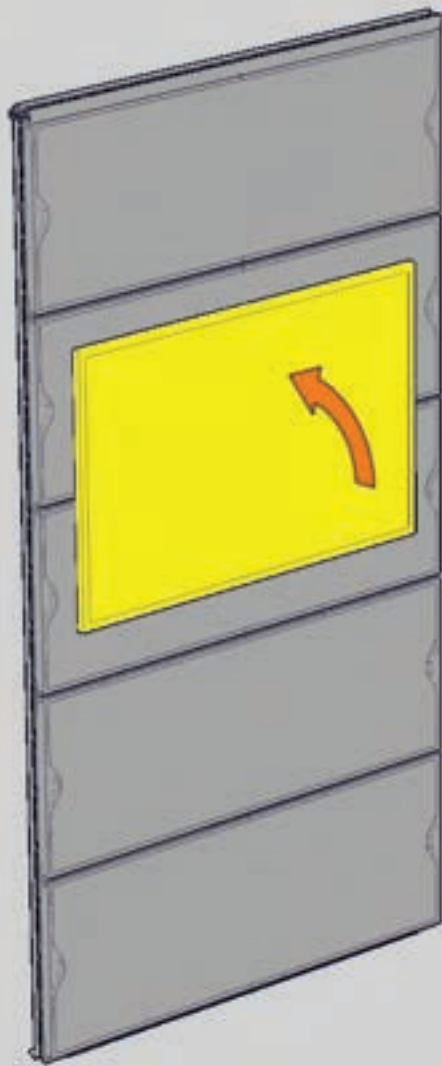

IT IS THE RESPONSIBILITY OF THE CUSTOMER TO MOUNT THE BRACKETS ONTO THE DISPLAY SCREEN

SCREEN MUST BE LOCKED WITH FIXINGS

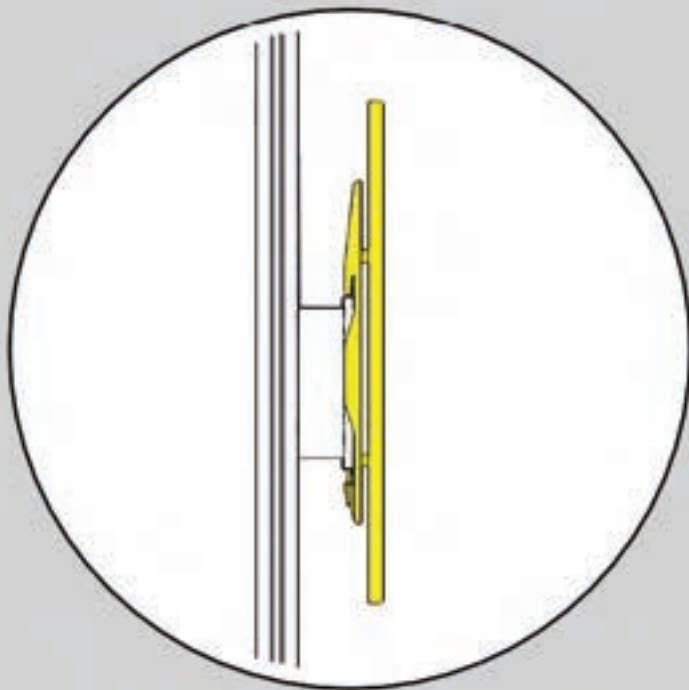

1

USING 2 PEOPLE, CAREFULLY LIFT THE SCREEN AND HOOK ONTO THE SCREEN MOUNTED BRACKET. ENSURE IT IS FULLY SECURE BEFORE LEAVING

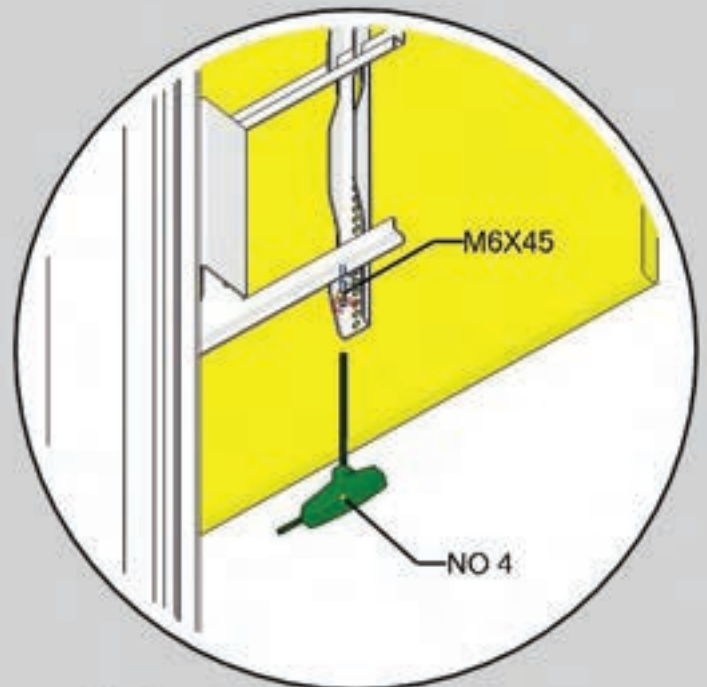

2

LOCK THE BRACKETS TOGETHER USING THE FIXINGS PROVIDED



TWO PERSONS MINIMUM

HOOP MOUNTED FIXED BRACKET

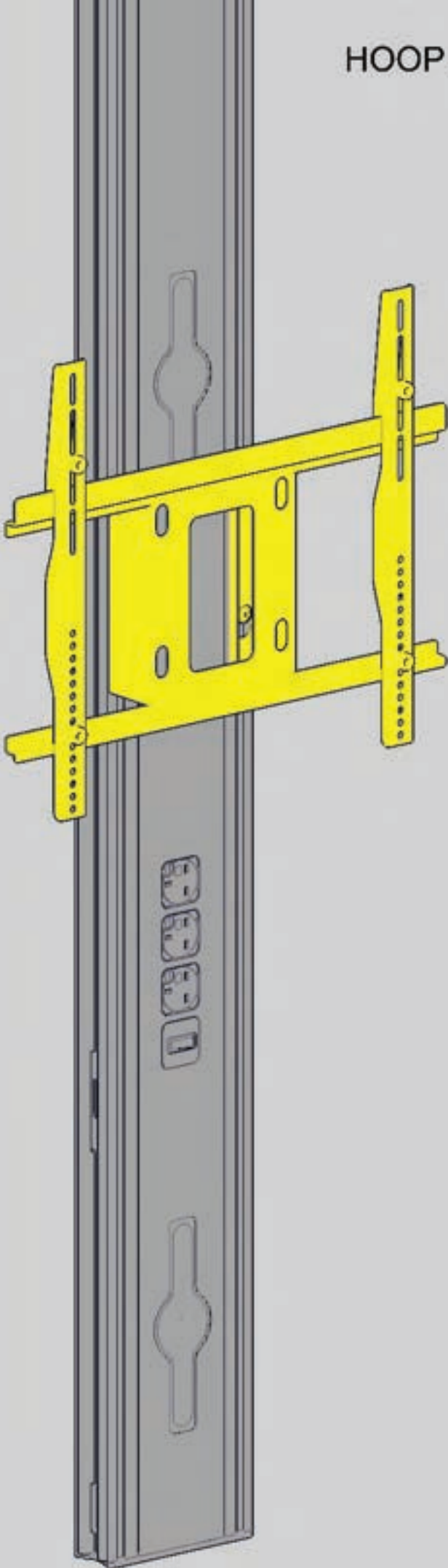

CAUTION:



LED	LCD
PLASMA	DO NOT EXCEED 55" OR 25KG (55LBS) ON ANY SCREEN



LOCATE X4 ROLL IN FIXINGS INTO HOOP UPRIGHT

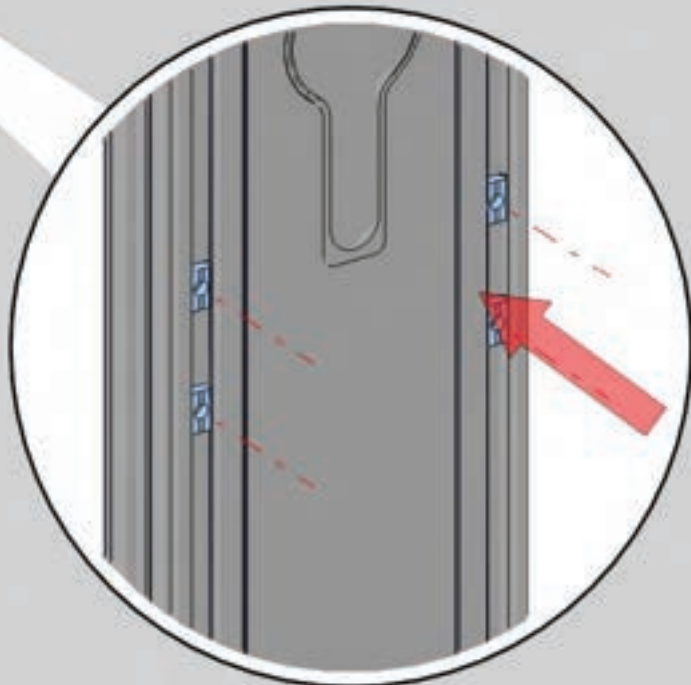

ONE PERSON MINIMUM

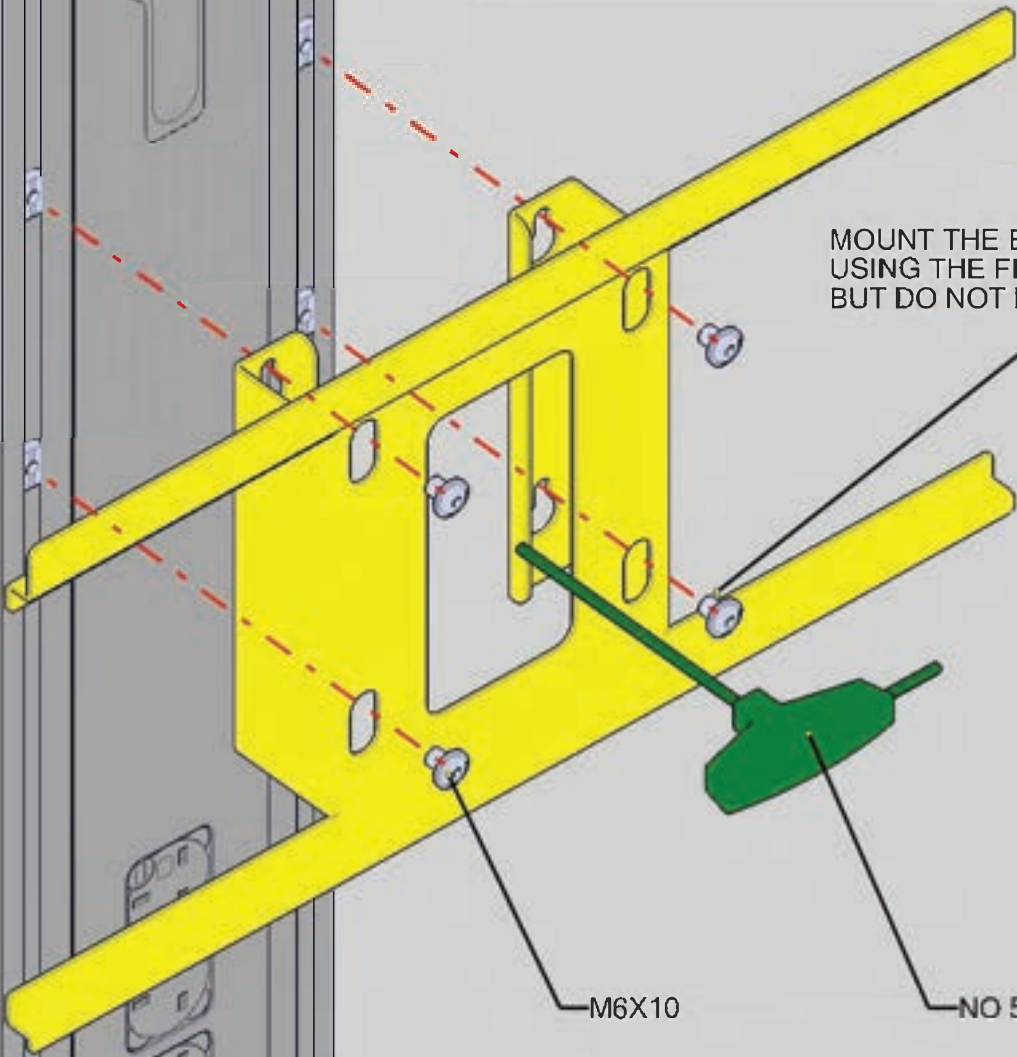

MOUNT THE BRACKET AS SHOWN
USING THE FIXINGS PROVIDED
BUT DO NOT FULLY TIGHTEN

TORQUE
6NM (4.42 FT-LBF)

M6X10

NO 5



ONE PERSON MINIMUM

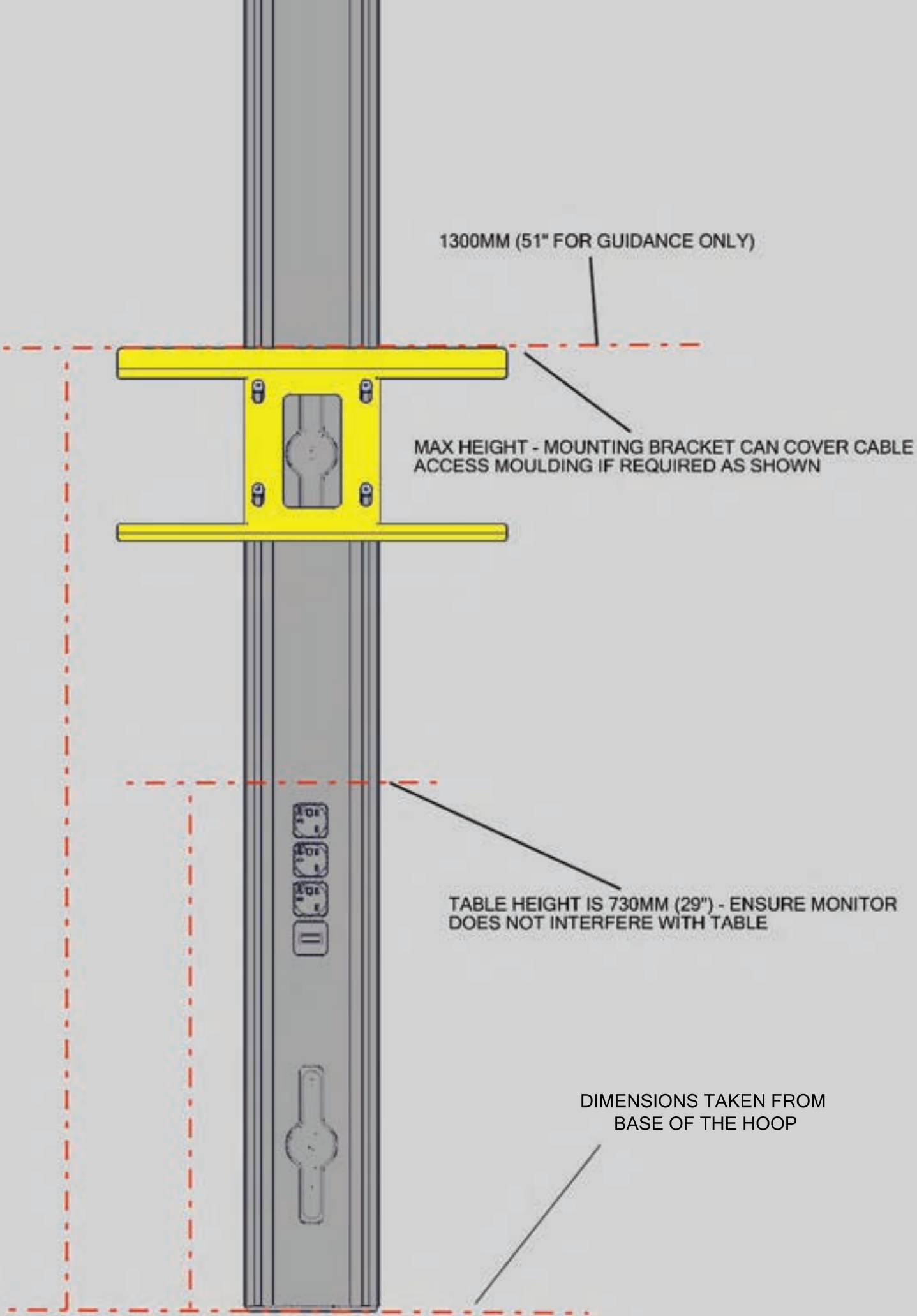

ONE PERSON MINIMUM

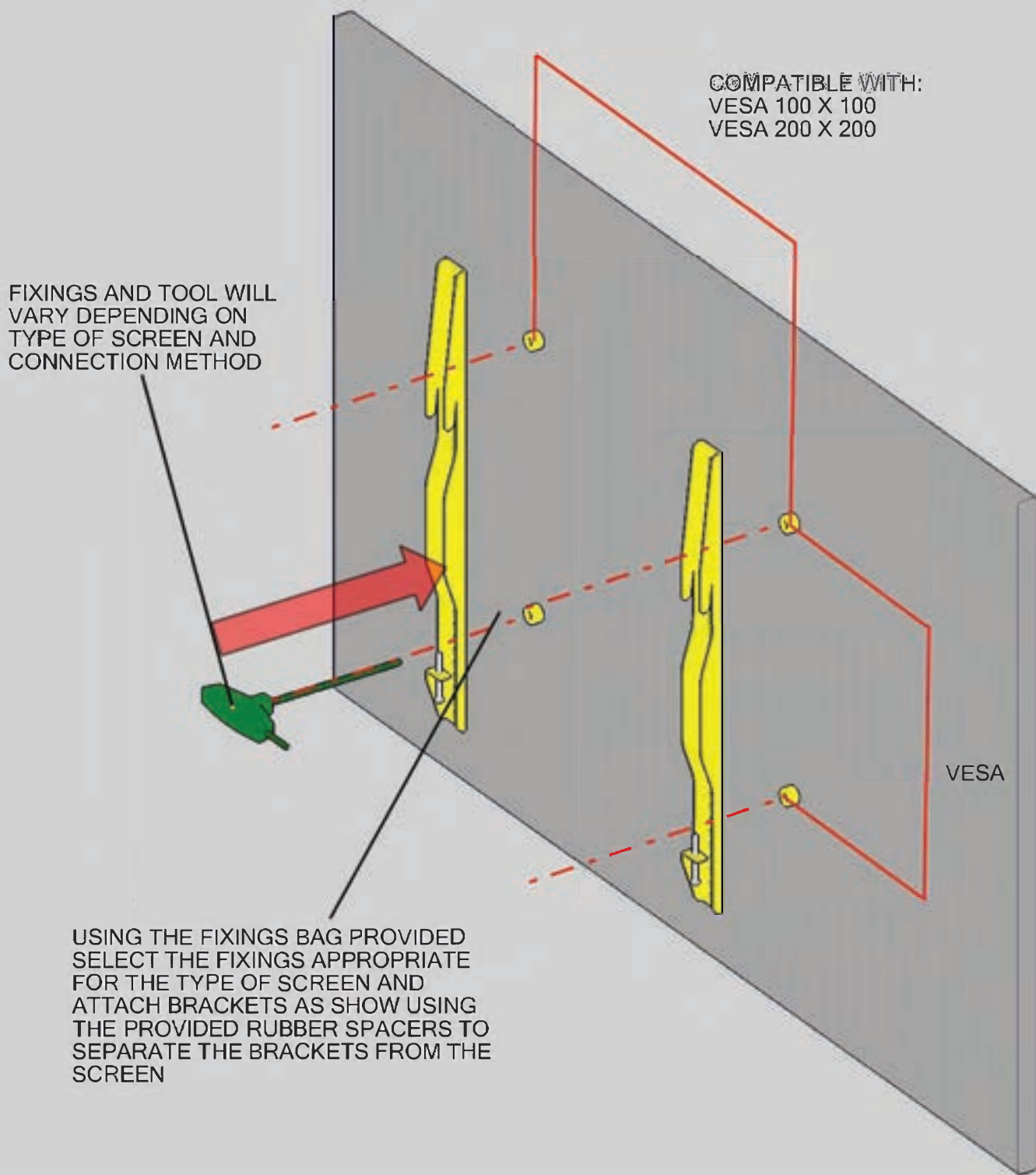

TWO PERSONS MINIMUM

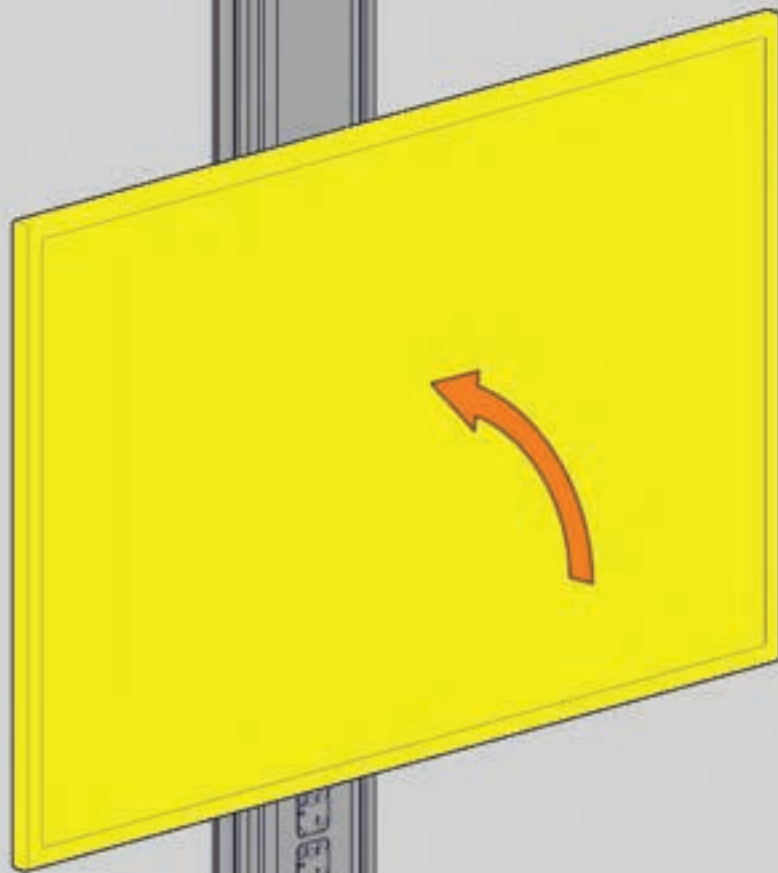

IT IS THE RESPONSIBILITY OF THE CUSTOMER TO MOUNT THE BRACKETS ONTO THE DISPLAY SCREEN

SCREEN MUST BE LOCKED WITH FIXING

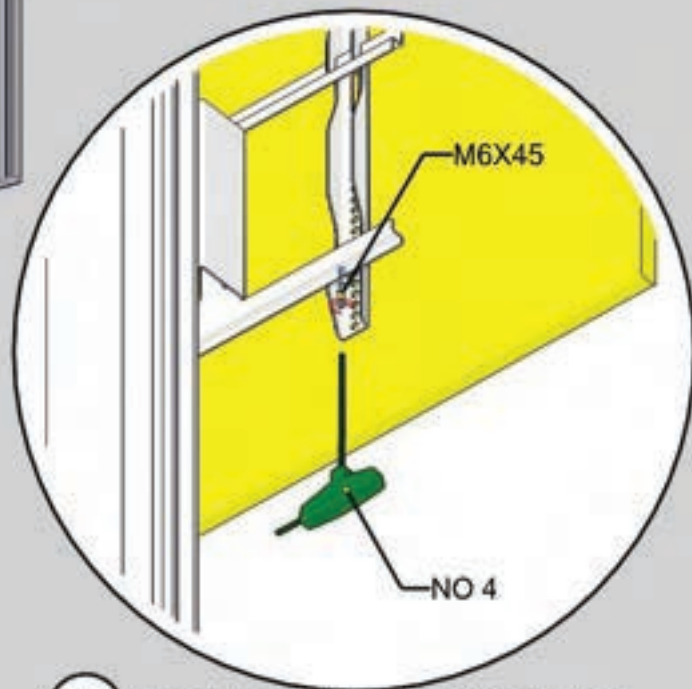
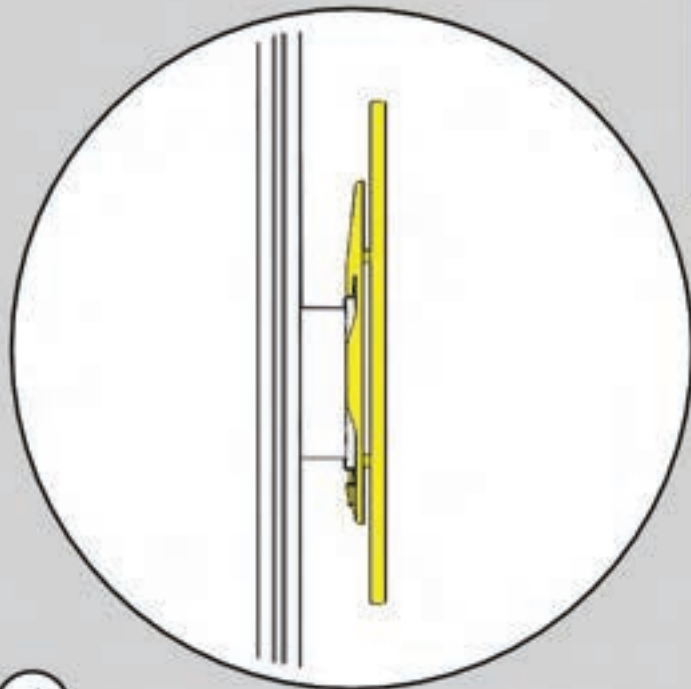

1 USING 2 PEOPLE, CAREFULLY LIFT THE SCREEN AND HOOK ONTO THE HOOP MOUNTED BRACKET. ENSURE IT IS FULLY SECURE BEFORE LEAVING

2 LOCK THE BRACKETS TOGETHER USING THE FIXINGS PROVIDED



TWO PERSONS MINIMUM

HOOP MOUNTED TABLES

SMALL TABLE AIR-30 US

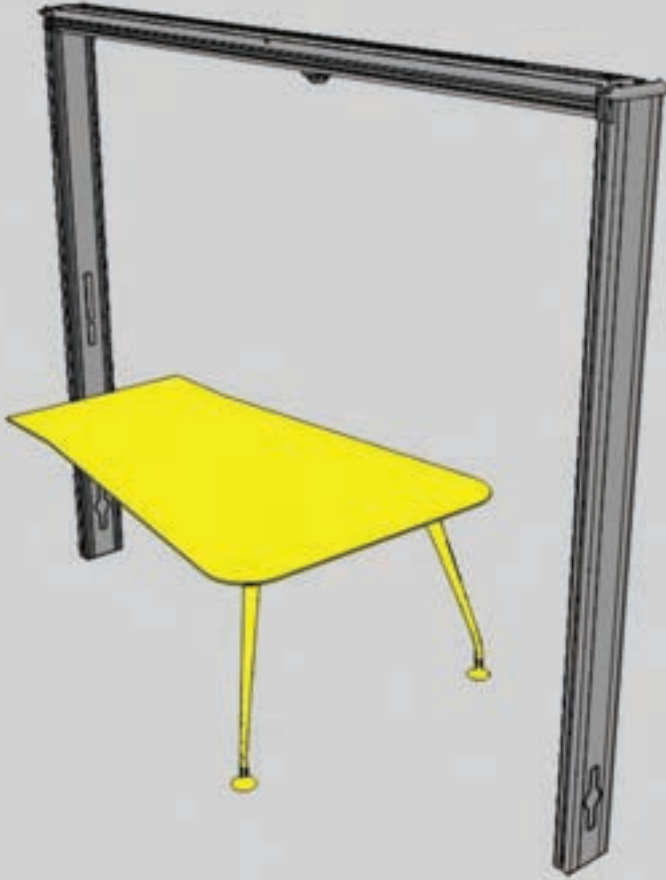

TWO PERSONS MINIMUM

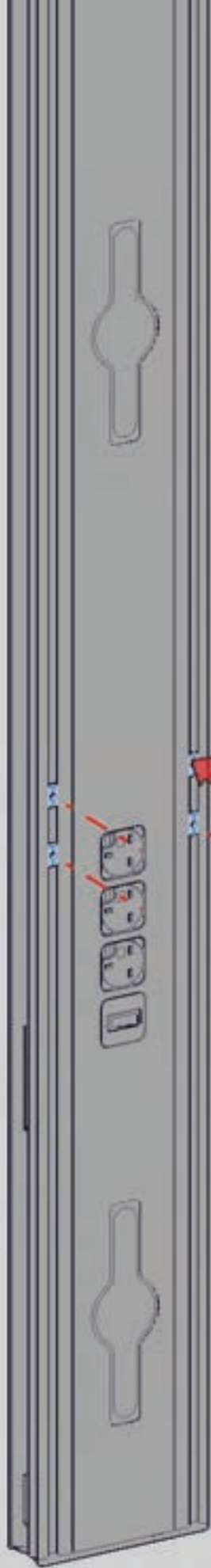

LOCATE QTY 4 ROLL IN FIXINGS INTO THE HOOP UPRIGHT

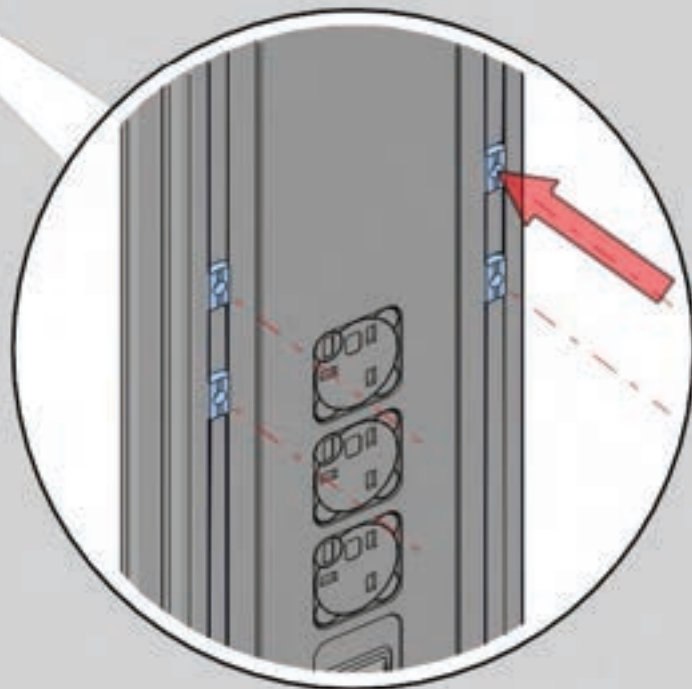

ONE PERSON MINIMUM

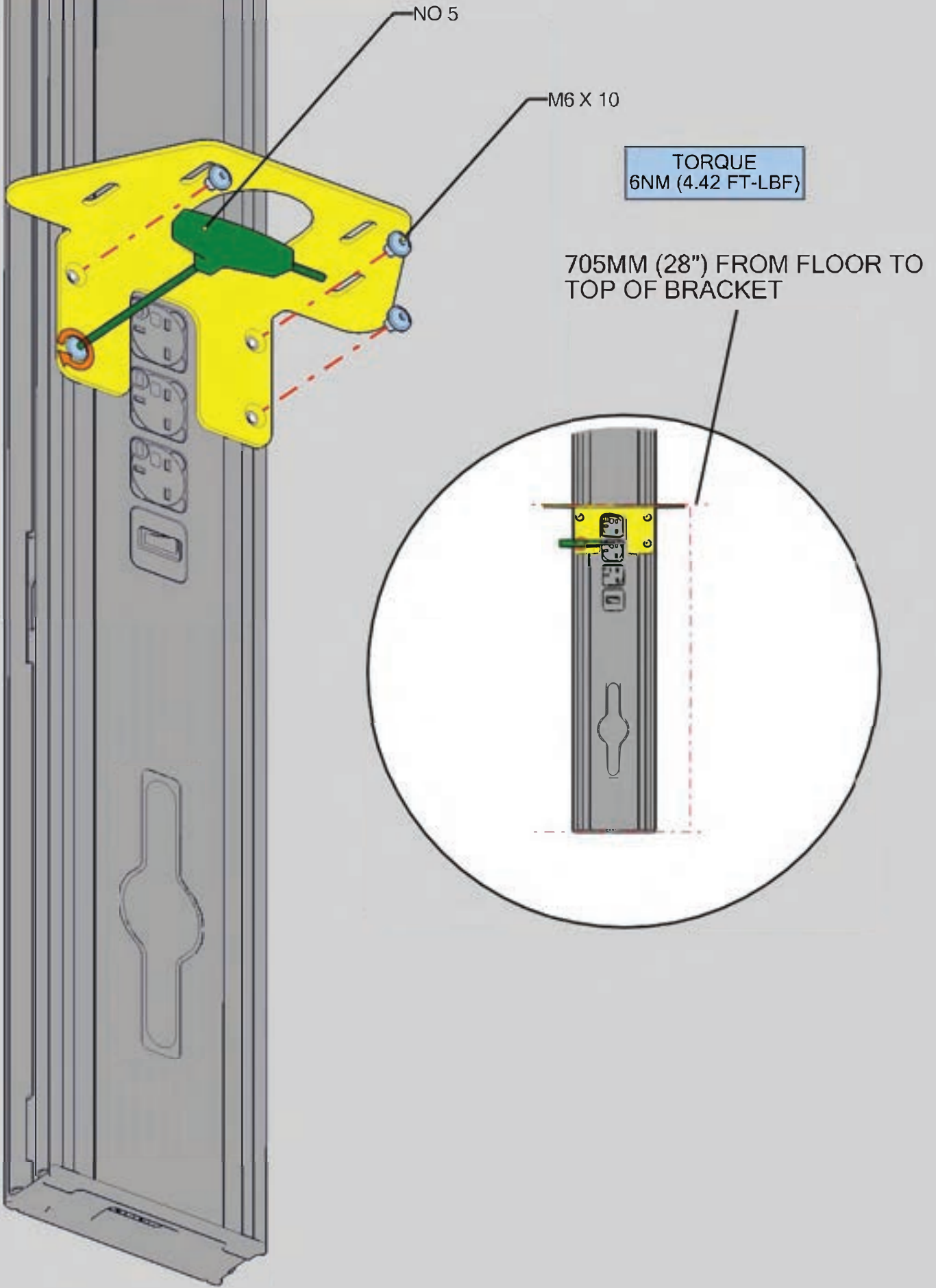

ONE PERSON MINIMUM

TORQUE
3NM (2.21 FT-LBF)

M6 X 16 POZI PAN

POZI 3 SCREWDRIVER

1 TURN TABLE OVER AND MOUNT LEGS USING FIXINGS PROVIDED

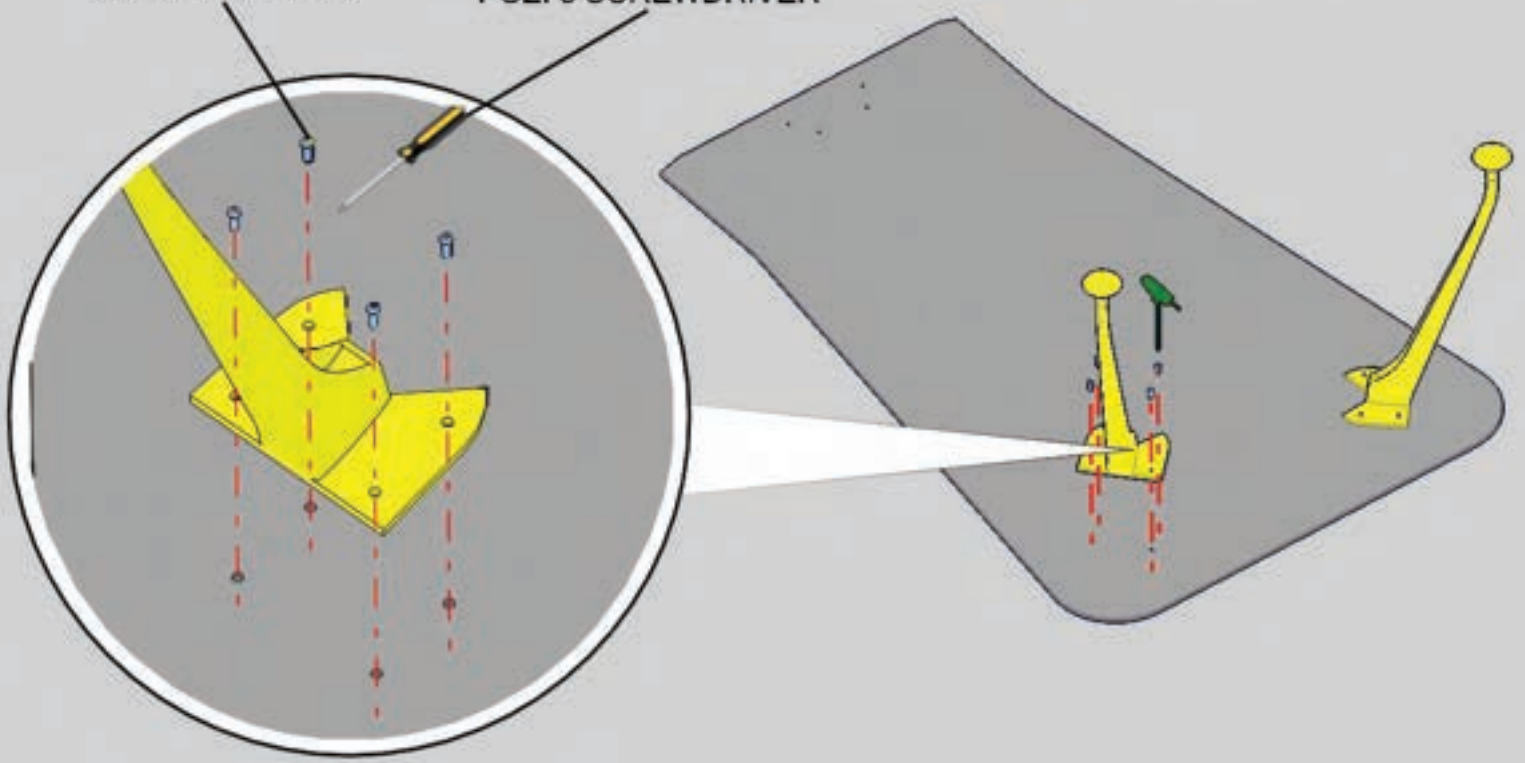

2 LIFT TABLE INTO POSITION ON HOOP BRACKET

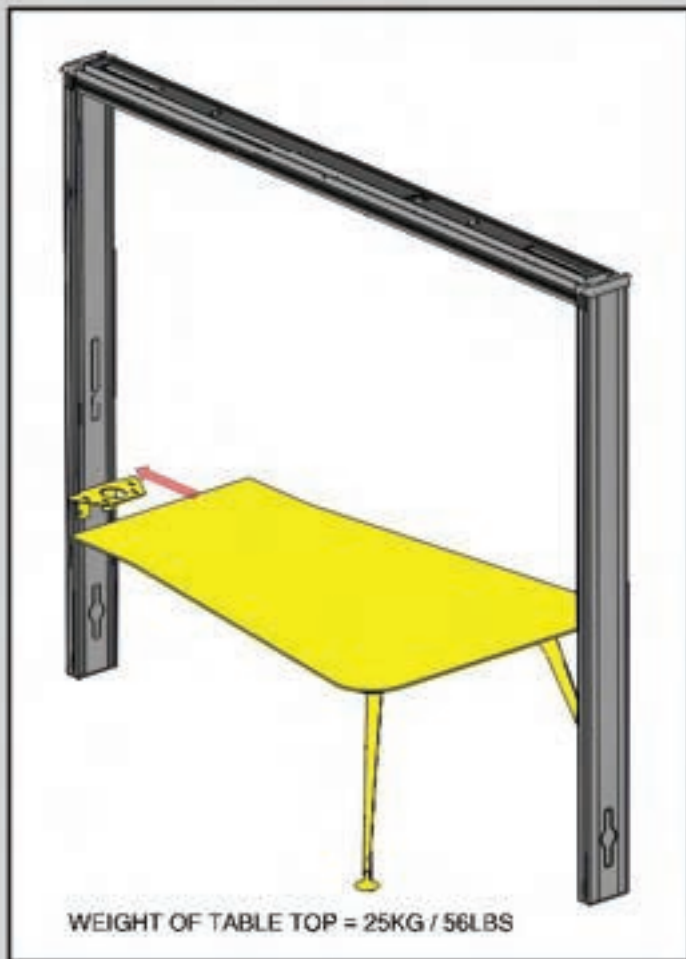

3 SECURE TABLE INTO POSITION

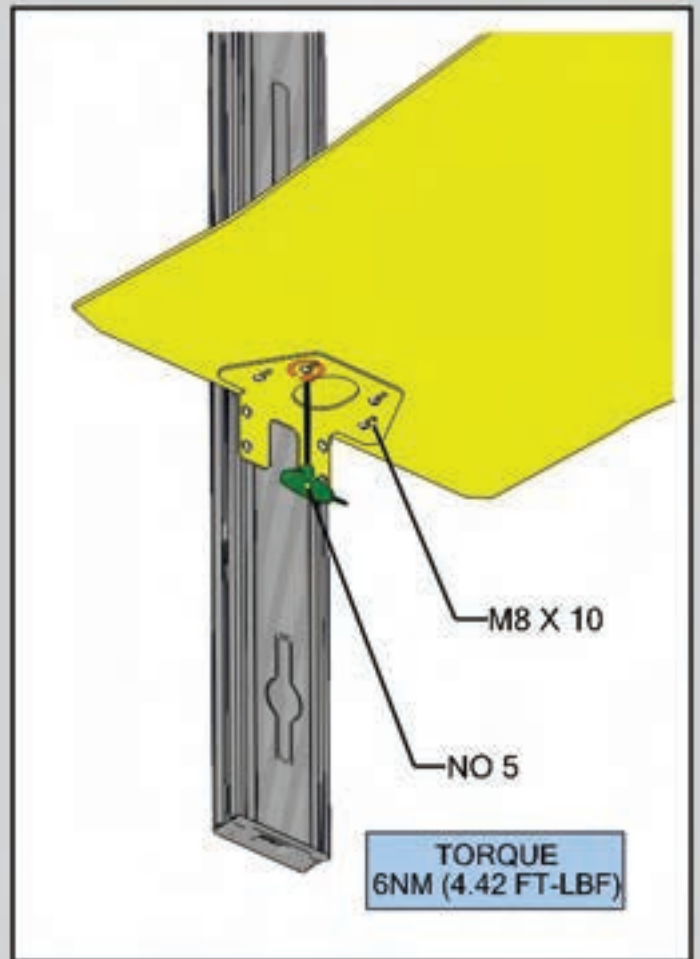

TORQUE
6NM (4.42 FT-LBF)



TWO PERSONS MINIMUM

ADA DOOR EXPANSION/NIB

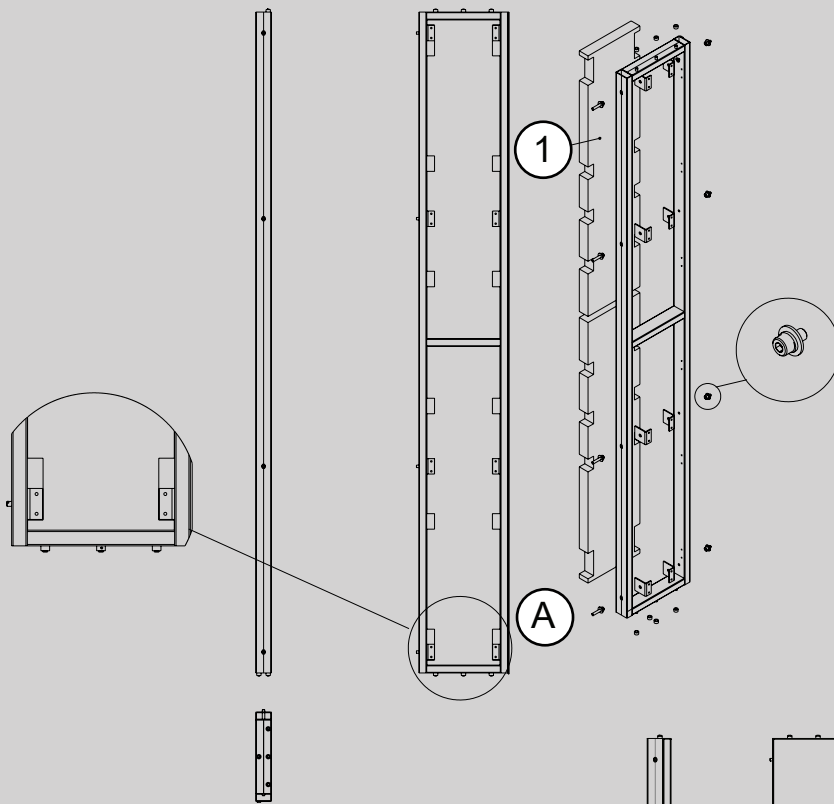
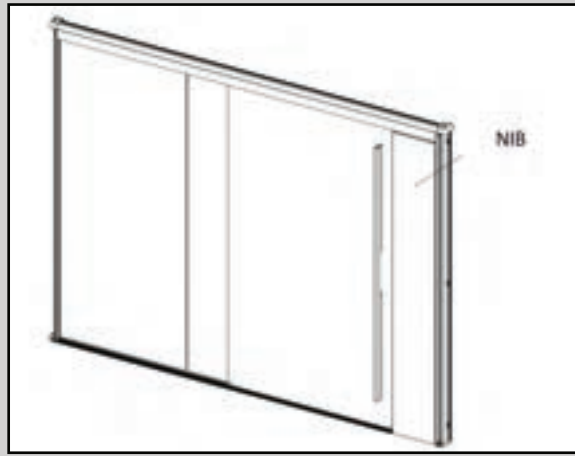

Step 1:

The support frame is installed into the slots of the current extrusion. See Detail A.

M8x40 screws fix the support frame to the amended upright of the pod.

Both M8 variants hold the panel bracket in place. A form C washer and spring washer are used to position and tension.

Insert the Rockwool panels (1) into the frame.

Step 2:

Using the countersink self tapping screws (2), attach the male keku brackets (3) to the support frame.

Using the pan head self tapping screws (4) attach the rear tray to the support frame.

Step 3:

Apply the front tray assembly to the frame, mating the keku clips together.

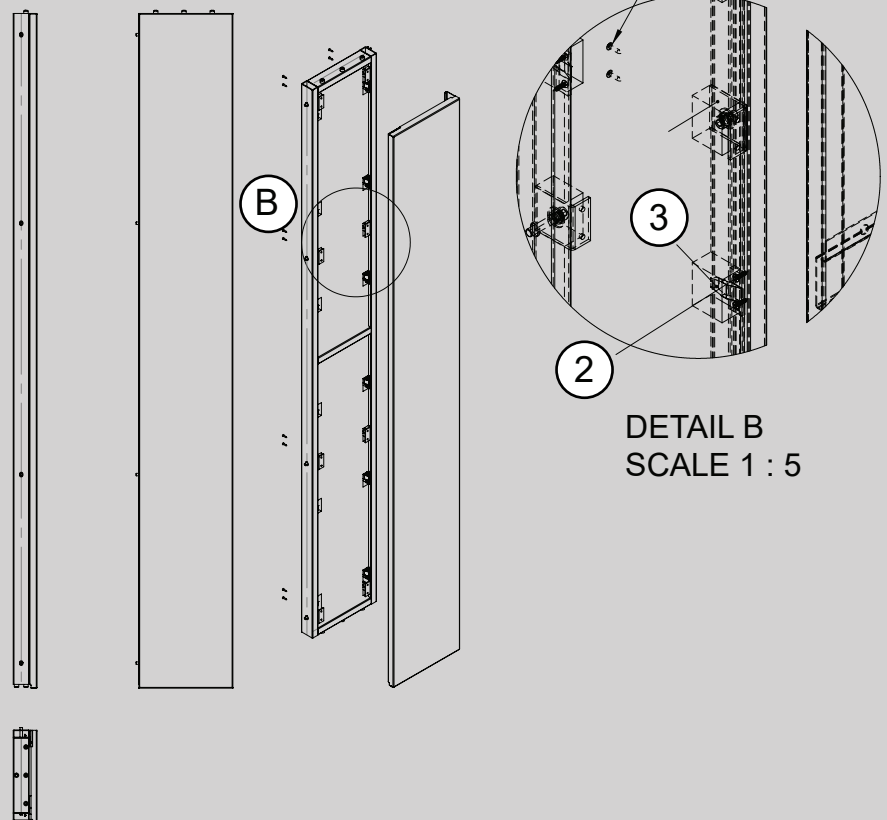

Assembly sequence

The Knack. Insider tips

section

10

Contents page

Plastic / Rubber seals.....	10.2
Pod Alignment template jigs.....	10.3
Screen hook positions Upholstery Screen crossbar.....	10.4
Upholstery screen to hoop alignment 1 Upholstery screen to hoop alignment 2.....	10.5
Upholstery screen to front/rear glass frame alignment Bottom door track to upright.....	10.6
Door track to screen block Glass edge cleaner.....	10.7
Sealing the glass panels Door track packing adjustment.....	10.8
Roof panel alignment Securing the opening roof.....	10.9
Adjusting the opening roof.....	10.10
Door adjustment tips.....	10.11-10.12
Door handle alignment Caught internal glass seal.....	10.13
Starting off the glass seal Sealing the glass externally.....	10.14
Mounting the front / rear covers Upholstery panel height adjustment.....	10.15
Mini-pod light connection Corner trim caps.....	10.16
Mounting the upholstery panels.....	10.17

1. Plastic/Rubber Seals.

When: Check all plastic and rubber seals are assembled correctly prior to any assembly.

Why: If a seal is noticed to be pulled out and not engaging correctly late on in the build, the pod will need to be dismantled to put right.

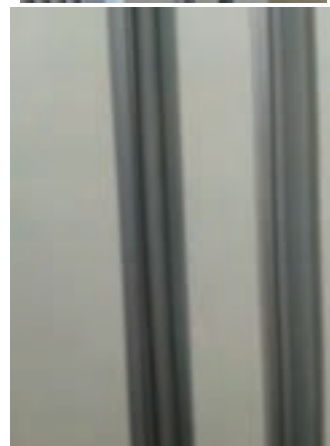
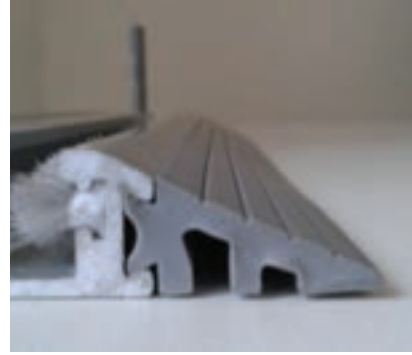
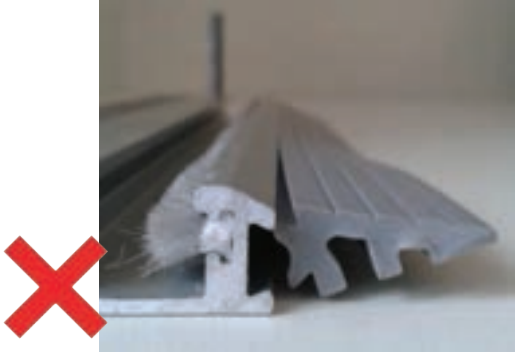

2. Pod Alignment Template Jigs.

When: To be assembled in position before the build.

Why: To guarantee Pods will be built to accurate dimensions and angles, otherwise problems will occur throughout the build. Also to confirm the position with the client prior to building.

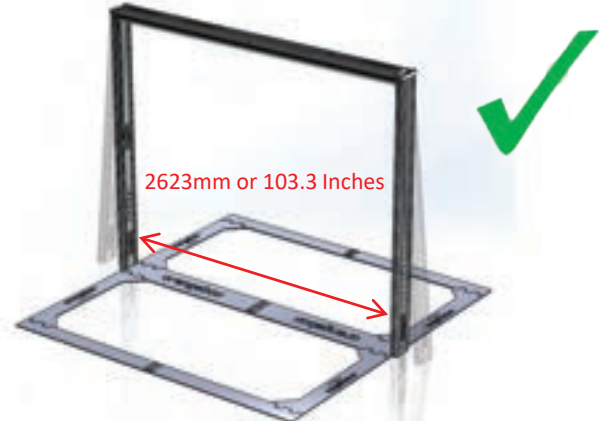

Pods built misaligned become parallelograms and will affect the glass install.

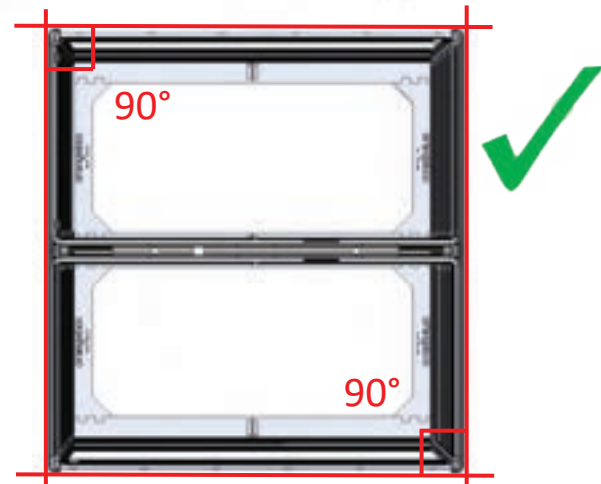

Building around the floor template jigs will guarantee all angles and dimensions are correct.

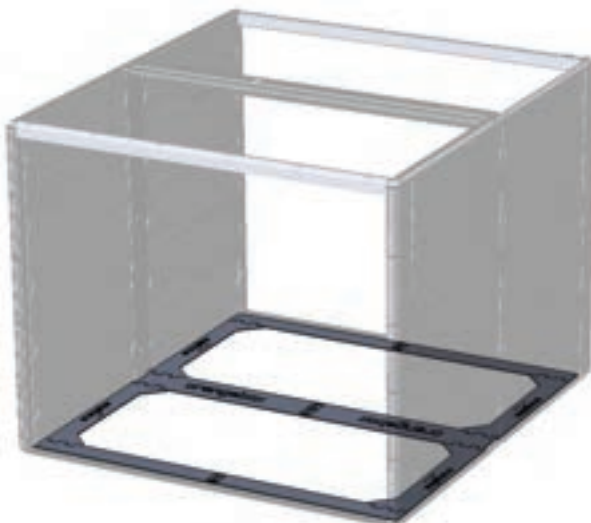

3. Screen Hook Positions .

When: Check the hook positions on each screen before hooking them onto the hoop.

Why: The height will be misaligned causing gaps throughout and covers will fit poorly.

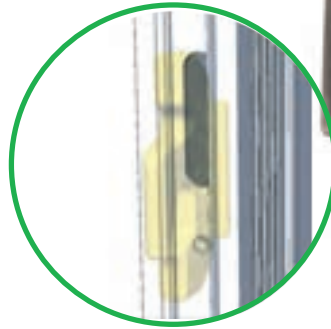

The screw must be located over the detail in the extrusion.

4. Upholstery Screen Crossbar.

When: Check the crossbar is flush with the top of the upholstery screen, ideally before hooking them onto the central hoop.

Why: Covers will not align and gaps will appear when attaching corner caps otherwise.



Use a rubber mallet and block to re-align the top crossbar



5. Upholstery Screen to Hoop Alignment.

When: Ensure the screen height aligns accurately with the hoop casting when hooking into the hoop. Use a soft mallet if necessary.

Why: The top covers and upholstery panels will be misaligned and cause gaps throughout. Tap down with a soft mallet if necessary.



6. Upholstery Screen to Hoop Alignment 2.

When: Ensure the screens are tight up against the hoop with no gaps between when hooking into the central hoop. Use a clamp across both screens if necessary.

Why: The pod will be misaligned and cause gaps between upholstery panels. Tap down with a soft mallet if necessary.



7. Upholstery Screen to Front/Rear Glass Frame Alignment.

When: Ensure the screens align accurately with the front/rear frames, when bolting the frame uprights onto the screens.

Why: The pod will be misaligned and cause gaps throughout.

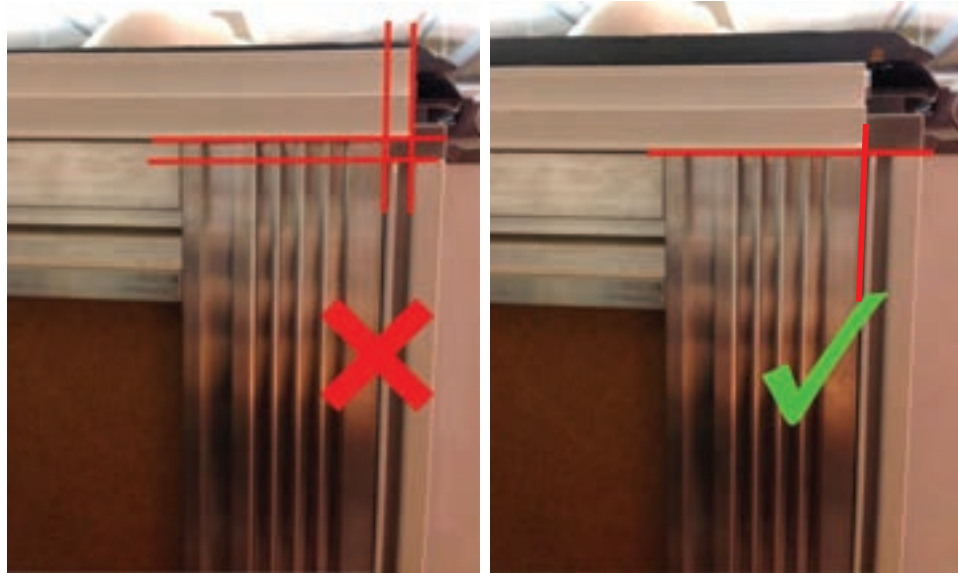
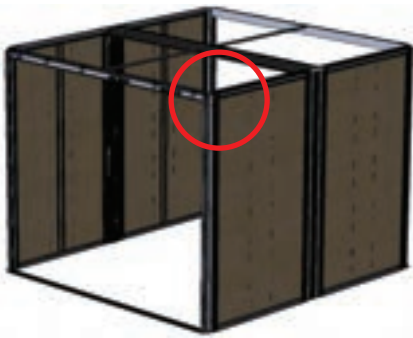

8. Bottom Door Track to Upright.

When: When assembling the front/ rear glass frame always sit the upright onto the door track completely parallel.

Why: The upright will not fit correctly. The component may get damaged.

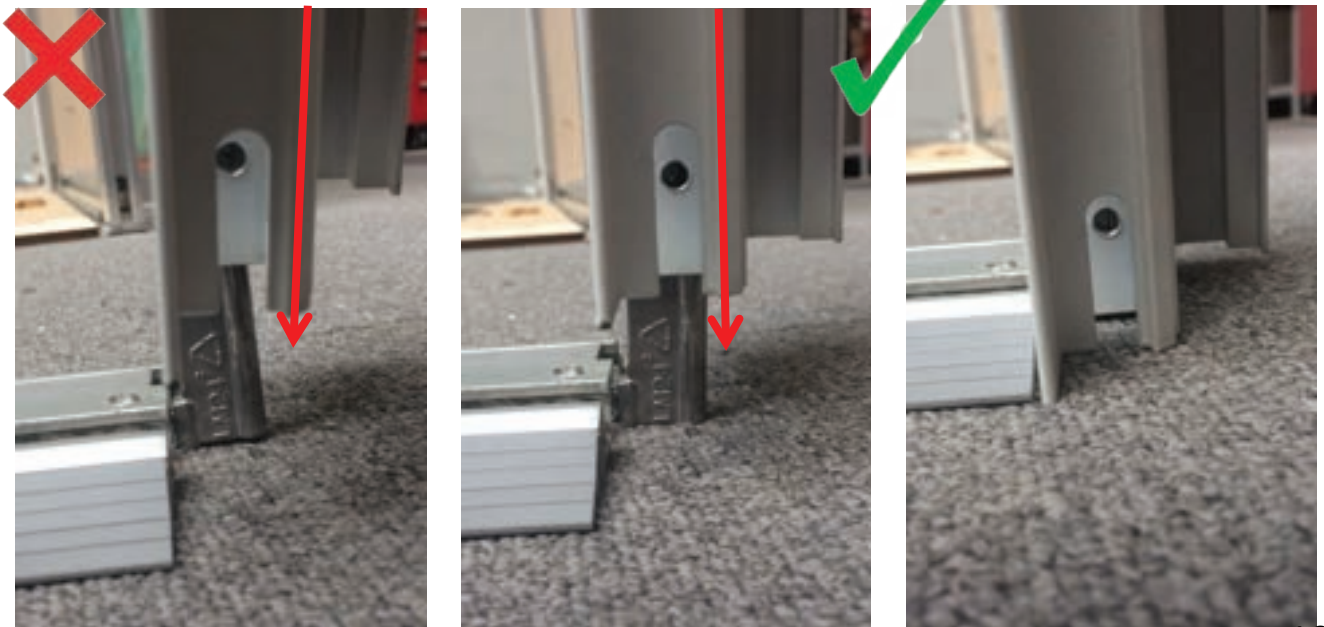

9. Door Track to Screen Block.

When: Ensure the block is inserted before the door track is bolted on .

Why: Gaps will appear in each corner



Place the block into position when the upright is being attached to the screen.

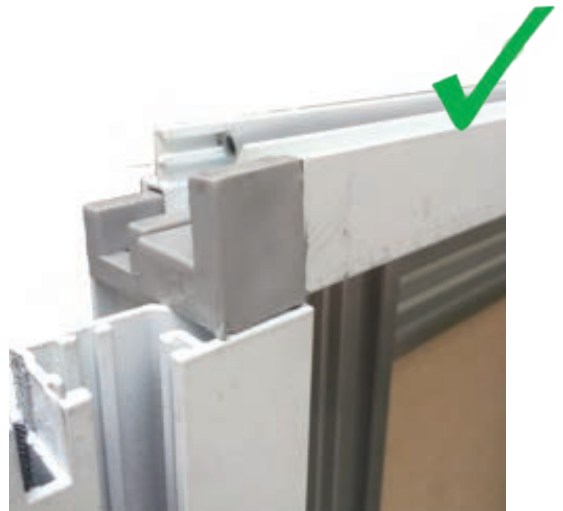

10. Glass Edge Cleaner.

When: The glass edges must be cleaned using the Isopropanol wipes prior to any plastic extrusion being bonded on.

Why: The bonding tape will not fully stick to the glass edges as dust/grime reduces its adhesion.



One continuous wipe down the glass edge per cleaning wipe, so to not wipe dirt/grime back over the cleaned areas.

11. Sealing the Glass Panels.

When: When sealing the glass panels against each other, test the closure by blowing through the gap and checking for a draught or attempting to push a thin piece of material through.

Why: If the glass panels are not sealed correctly there will be sound gaps which will affect the acoustic performance.



Tip: place a sucker on each side of the join and use a clamp to squeeze the glass panels together.

12. Door Track Packing Adjustment.

When: During the assembly of the front door track, stick one/ two packer /shim pads onto middle glass panel to correct and maintain the height.

Why: Stops door track sag/ loss of height (due to the weight of the door) and stops door scrape.

The distance between the underside of the top door track and the top face of the bottom door track **MUST** be 2140mm or 84.25 Inches

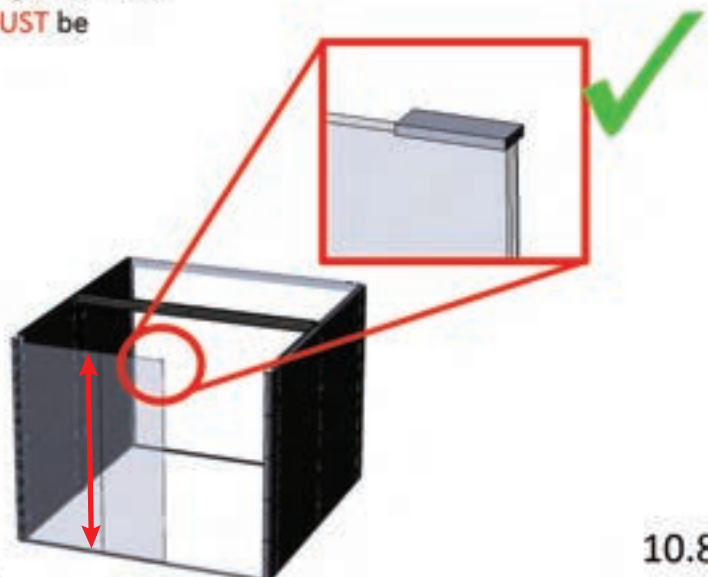

13. Roof Panel Alignment.

When: When mounting the roof panels ensure that the roof panel edge sits in the middle of the hoop casting each side.

Why: The roof panels will be misaligned causing the opening/ closing movement to be poor.

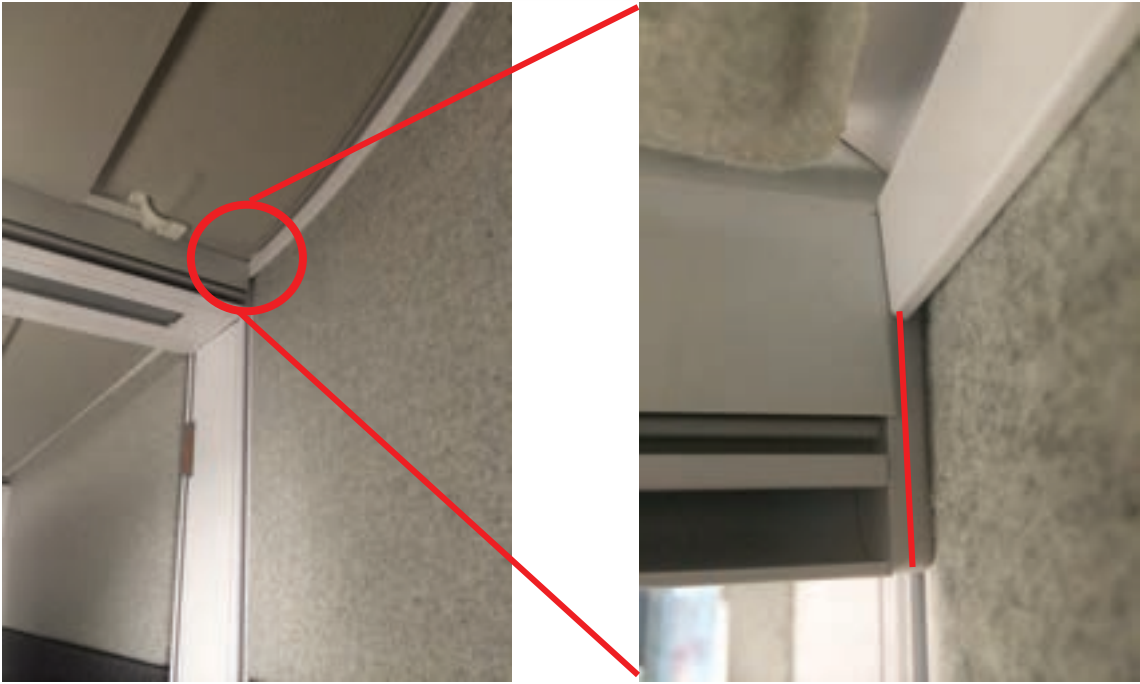

14. Securing the Opening Roof.

When: After locating all the roof panels, apply an even force around each to secure.

Why: The opening roof movement will be disrupted if all roof panels are not mounted evenly and accurately.

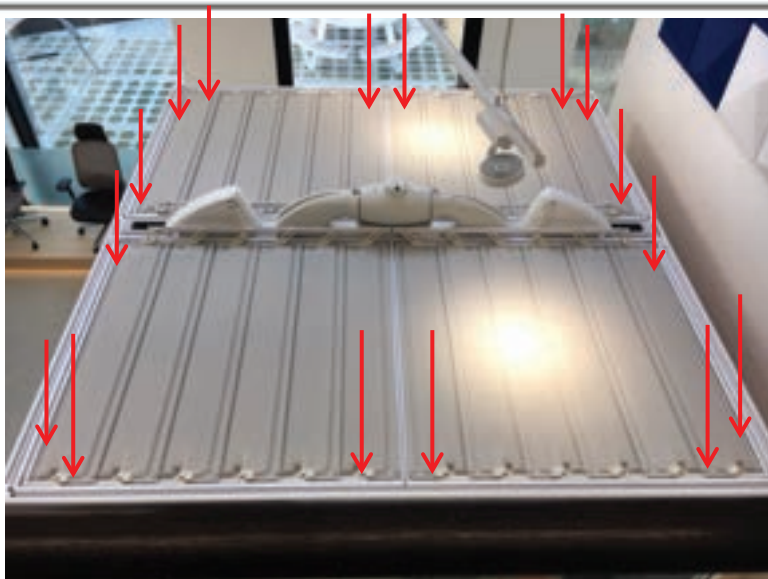

15. Adjusting the Opening Roof.

When: Once operational, loosen the actuator bracket and push towards the middle of the pod until all roof blades are firmly closed, then re-tighten.

Why: Gaps may be visible between the roof blades when fully closed



Push into the center of the Pod
to reduce the roof blade gaps.

16. Door Adjustment- Tips

When: Before mounting the door.

These are crucial tips on how to mount the door successfully.

Why: Without following these tips, the door will be mounted incorrectly or poorly.

1. Set the runner wheels to the neutral positions as shown below.



2. Mount the runners onto the door, tightening the 3 main screws on each to 14Nm using a torque wrench and ensure the wheels are in their neutral positions.



When: After mounting the door.

Why: Door Levelling correctly to create a smooth running and good alignment with the door frame upright.

3. Adjust the outer wheels first to set the overall height of the door. Ensure the door does not scrape on the bottom door track, but run within track brushes



3. Close the door to inspect the level, ensuring there is an even gap against the door upright.

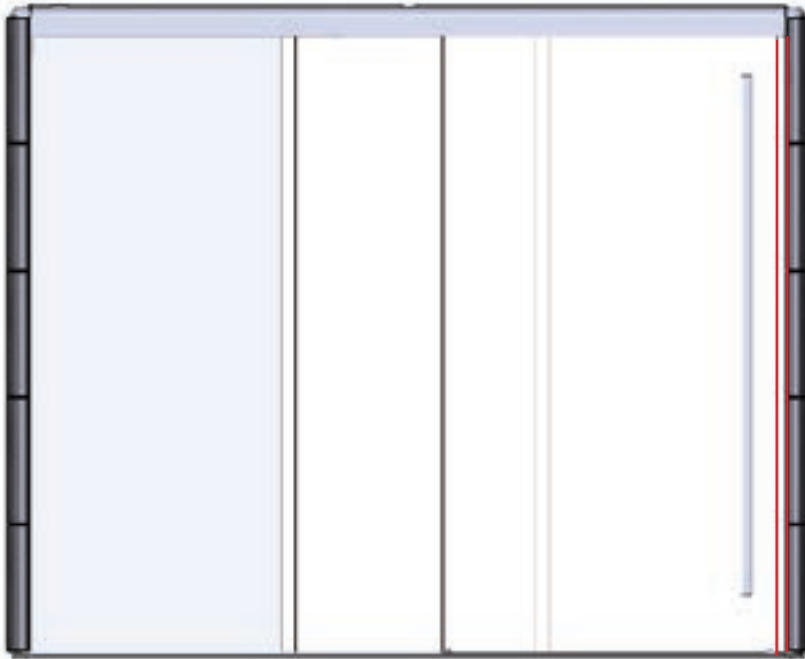

Recommended
door force:
Max: 22.5N

4. If you are happy with the door movement/ alignment, adjust the inner wheels down to match the outside wheels, but do not over tighten



5. Adjust the locking wheels up against the extrusion to secure the door, but don't over tighten as this will mean the door is stiff.

*This locking wheel is critical for the safety of the door location within the track. It can also be used to control the free running speed of the door depending on how tight it is against the track.



17. Door Handle Alignment.

When: When mounting the door handle onto the glass door, ensure the extrusions are parallel and at 90° to the glass.

Why: The door handle can easily be mounted at an incorrect angle, putting stress on the glass fixing holes.

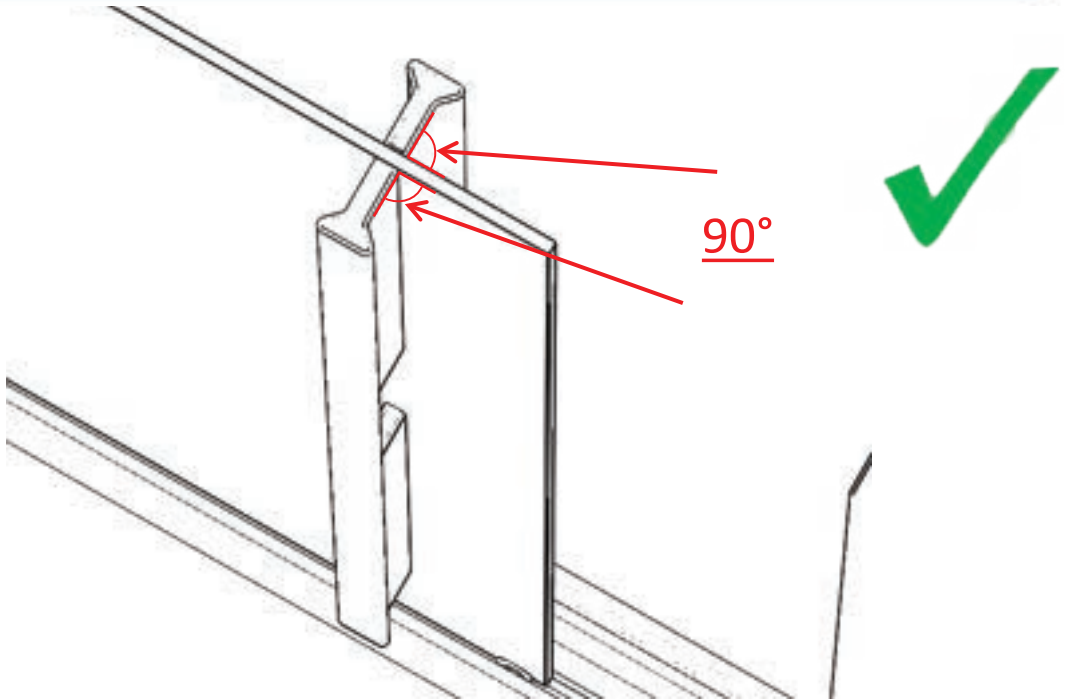

18. Caught Internal Glass Seal.

When: Run the spatula tool/ glass packer between the glass face to release the seal caught when installing the glass.

Why: Seal remains trapped.

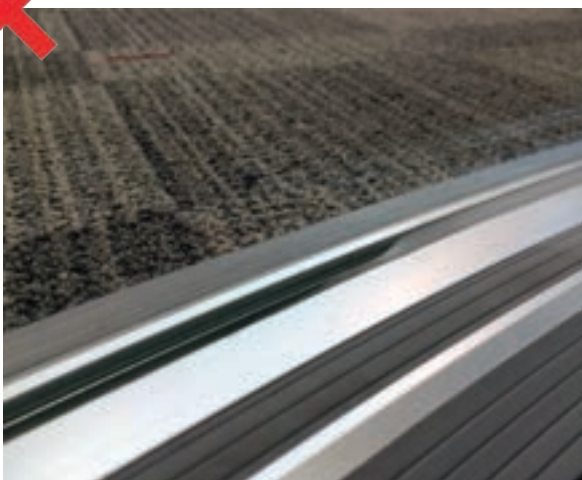

19. Starting off the Glass Seal.

When: Use the spatula tool/ Hoop opening tool to create enough space in the extrusion for the post fix glass seal to be inserted.

Why: The post fix glass seal can be very difficult to push in, especially on the curved glass frames.



20. Sealing the Glass Externally.

When: Push the Glass seal into position. Do not stretch the seal and run the tool along.

Why: Stretching the seal and pushing into position will mean over time the seal will shrink and leave gaps.

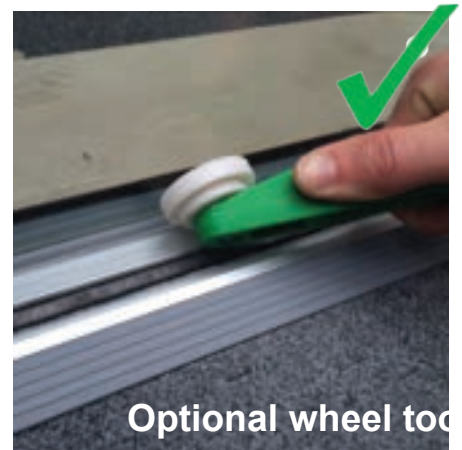
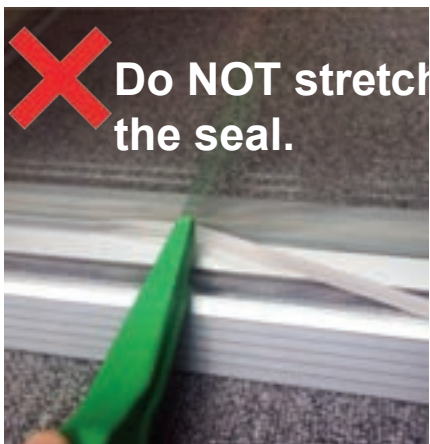

21. Mounting the Front/ Rear Covers.

When: Ensure the covers are located into the clips correctly, to hide/ protect the door runners and glass clamps.

Why: The covers will not be fully clipped on otherwise and may come loose/ fall off.

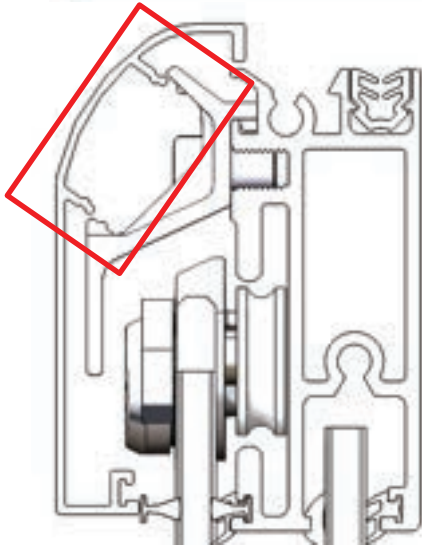

1. Locate the cover details inside the clips.

2. Apply force diagonally down to clip the cover on.

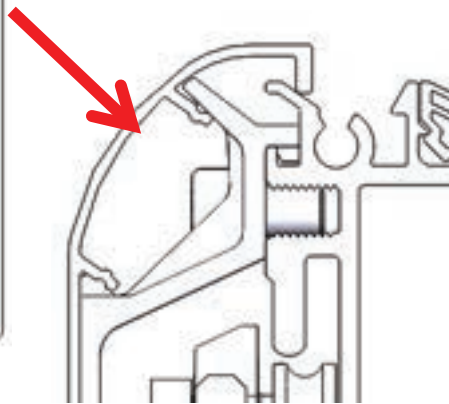

22. Upholstery Panel Height Adjustment.

When: After applying the Upholstery Panels, to close the gaps at the top, stick a packer pad (AIR-119-00) onto each anti slip bung.

Why: Gaps could appear at the top of the screen showing the framework.

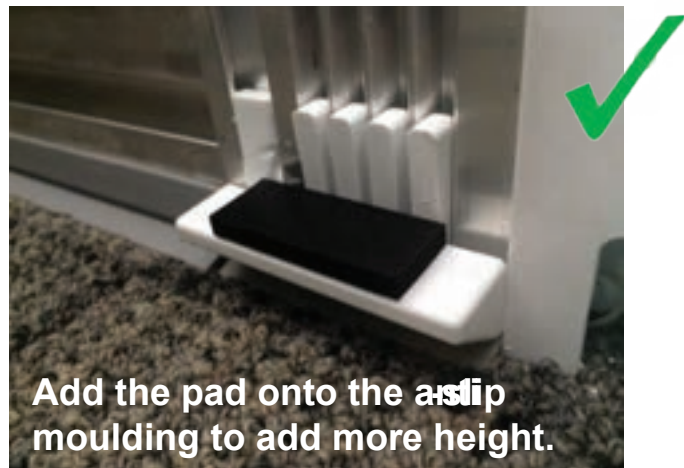

Add the pad onto the anti slip moulding to add more height.

23. Corner Trim Caps

When: Before the outside upholstery panels and front/rear track covers are mounted.

Why: The corner trim moulding will not fit into place with these parts mounted before.



Align the corner trim up to its mating details in the extrusions.



Using a T-bar and mallet, push the boss into the extrusion.



Push the moulding until it meets the screen cover.

24. Mounting the Upholstery Panels

When: Push down firmly in the areas highlighted to properly engage the panel clips into the screens.

Why: If any of these clips are not engaged correctly the upholstery panel become loose.

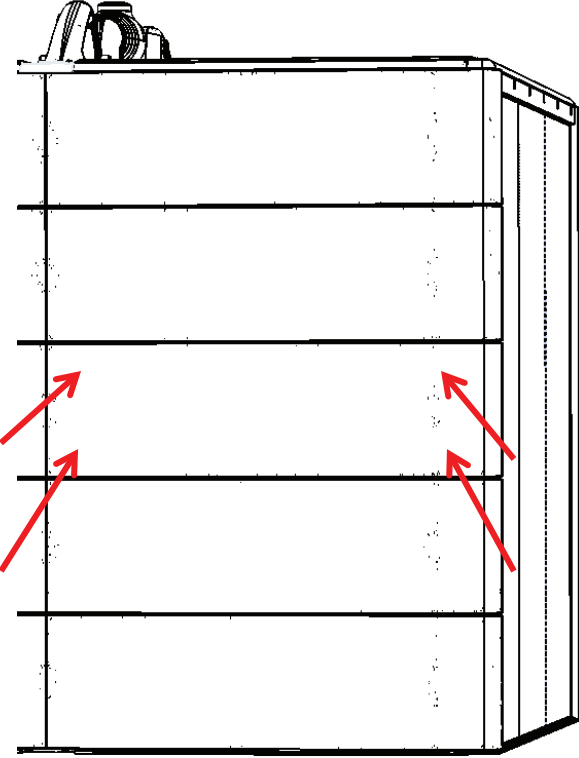

Apply force to the 4 areas highlighted to engage the clips into the screen extrusions.

*On interior panels repeat this in the centre of each panel to engage into the central strip.